

THIS INSTRUCTION BOOKLET CONTAINS **IMPORTANT** SAFETY INFORMATION. PLEASE READ IT CAREFULLY AND KEEP FOR FUTURE REFERENCE.

ESTE MANUAL DE INSTRUCCIONES CONTIENE INFORMACION SEGURA E **IMPORTANTE** POR FAVOR LEA CUIDADOSAMENTE Y MANTENGA PARA FUTURAS REFERENCIAS.

CE LIVRET D'INSTRUCTIONS CONTIENT **D'IMPORTANTES** INFORMATIONS SUR LA SÉCURITÉ. VEUILLEZ LE LIRE ET LE CONSERVER POUR CONSULTATION ULTÉRIEURE.



**DO NOT RETURN PRODUCT TO THE STORE**  
Individual stores do not stock parts.

**NO REGRESE EL PRODUCTO A LA TIENDA**  
independientes no tienen las partes

**NE RETOURNEZ PAS LE PRODUIT AU MAGASIN**  
Les détaillants ne gardent pas de pièces.

Lot number /Numero/ Numéro de lot : \_\_\_\_\_  
Date of purchase /Fecha que compro/ Date d'achat : \_\_\_\_/\_\_\_\_/\_\_\_\_

If a part is missing or damaged, call our toll-free customer service line. We will gladly ship your replacement parts FREE of charge.

Si una pieza esta dañada o perdida llame a nuestro teléfono Del servicio al cliente. Con gusto le enviaremos las partes Para reemplazar las dañadas. No hay cargos adicionales es gratis.

Si une pièce est manquante ou endommagée, composez le numéro sans frais de notre service à la clientèle. Nous expédierons vos pièces de rechange GRATUITEMENT.

Need parts or assistance?  
¿Necesita partes o asistencia?  
Besoin de pièces ou d'assistance?

**1-800-489-3351**

or visit our website  
O visite nuestra página de internet.  
ou visitez notre site Web

[www.altrafurniture.com](http://www.altrafurniture.com)

For prompt, reliable service, please have your manual ready.

Para obtener un servicio rápido por favor tenga su manual a la mano.

Pour un service rapide et fiable, ayez en main votre manuel d'assemblage.

Recommended no. of people needed for assembly : 2

Se recomienda un número de personas para ensamblar: 2

Nombre de personnes nécessaires recommandé pour l'assemblage : 2

## Before starting - Antes de Empezar - Avant de commencer

- Read each section carefully before starting. It is very important that each step is performed in the correct order. If these steps are not followed in sequence, assembly difficulties will occur.  
Lea cada sección cuidadosamente antes de empezar. Es muy importante que cada paso este realizado en el correcto orden. Si estos pasos no se siguen en secuencia. El ensamblaje se dificultara.  
Lisez chaque étape attentivement. Il est très important que chaque étape de l'assemblage soit exécutée dans le bon ordre. Si ces étapes ne sont pas exécutées dans le bon ordre, vous risquez d'avoir des difficultés à assembler le meuble.
- Make sure all parts are included. Most board parts are labeled or stamped on the raw edge.  
Asegúrese que todas las partes estén incluidas. La mayoría de las partes de los tableros están etiquetados o estampados en el borde.  
Assurez-vous que toutes les pièces sont incluses. La plupart des pièces en bois sont étiquetées ou estampées sur le bord non fini.
- Work in spacious area, preferably on a carpet, near the place the unit will be located.  
Trabaje en un área amplia, preferiblemente sobre una alfombra, cerca del lugar que la unidad será ubicada.  
Travaillez dans un endroit spacieux, préférentiellement sur un tapis, près de l'endroit où le meuble sera utilisé.
- Have the following tools close at hand.  
Tenga las siguientes herramientas cerca y a mano.  
Ayez les outils suivants à la portée de la main.
- Do not use power tools to assemble your furniture. Power tools may strip or damage the parts.  
No use Herramientas eléctricas para armar su mueble. Herramientas eléctricas pueden romper o dañar las partes.  
N'utilisez pas d'outils électriques pour assembler votre mobilier. Les outils électriques peuvent endommager les pièces.

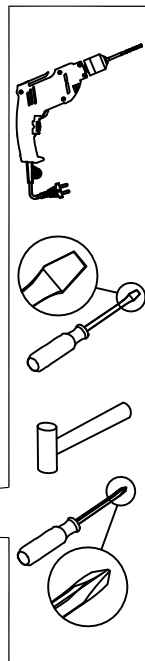

Call us at:  
Llámenos al : 1-800-489-3351  
Composez le:

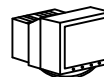

Visit our Website:  
Visite nuestra página de internet:  
Visitez notre site Web :

[www.altrafurniture.com](http://www.altrafurniture.com)

Monday - Friday  
9:00 a.m. - 5:00 p.m.  
Central Time

Lunes - Viernes  
9:00 a.m.-5:00 p.m.  
Hora Central

Du lundi au vendredi  
9 h à 17 h  
Heure normale du  
Centre

## HELPFUL HINTS

- Identify, sort and count the parts before beginning assembly.
- Compression dowels should be tapped in with a rubber mallet.
- Slides have a lip on the right side only.
- Back panels provide stability and support.
- Unit may collapse without the back panel installed.
- Clean the product with your choice of furniture polish and a soft cloth. DO NOT USE harsh chemicals or abrasive cleaners.
- Move your new furniture carefully. Two people are needed to lift and carry the unit to its new location.
- Never push, drag or scoot your furniture (especially on a carpet).

## CONSEJOS ÚTILES

- Identifique, clasifique y cuente las partes antes de empezar el ensamblaje.
- Los pasadores de compresión deben ser golpeados ligeramente con un martillo de goma
- Las correderas de cajón tienen un labio solo en la parte derecha.
- Los paneles traseros dan estabilidad a los muebles.
- El mueble puede colapsar si no se instala el panel trasero.
- Limpie el producto con el líquido de limpieza para muebles de su elección de muebles y un paño suave, no utilice químicos ásperos o limpiadores fuertes.
- Mueva el mueble cuidadosamente. 2 personas se necesitan para levantar y llevar la unidad al lugar deseado.
- Nunca empuje, arrastre o jale sus muebles (especialmente sobre alfombras).

## CONSEILS PRATIQUES

- Identifiez, séparez et comptez les pièces avant d'entreprendre l'assemblage.
- Insérez les goujons de compression avec un marteau.
- Les glissières ont un rebord seulement sur le côté droit.
- Les panneaux arrière stabilisent et soutiennent le meuble.
- Sans leur panneau arrière, les unités peuvent s'écrouler.
- Nettoyez le produit avec un poli à meubles et un linge doux. N'UTILISEZ PAS de produits chimiques ou de nettoyeurs abrasifs.
- Déplacez votre nouveau meuble avec soin, avec l'aide d'une autre personne et portez-le jusqu'à son nouvel emplacement.
- Ne poussez ou ne traînez jamais votre mobilier (surtout sur un tapis).

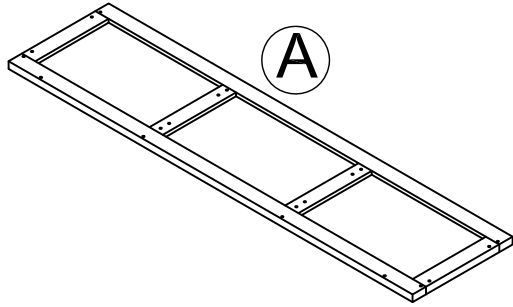

**A**  
TOP  
Panel superior  
DESSUS  
T1781096010

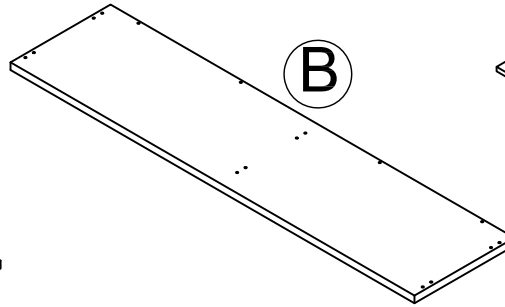

**B**  
BOTTOM PANEL  
Panel base  
PANNEAU INFÉRIEUR  
T1781096020

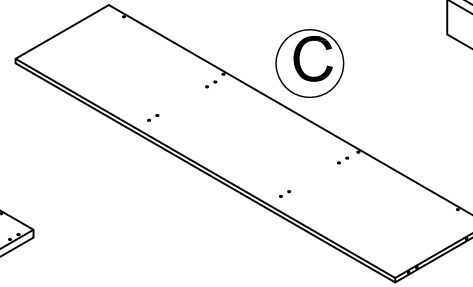

**C**  
FIXED SHELF  
Repisa fija  
ÉTAGÈRE FIXE  
T1781096030

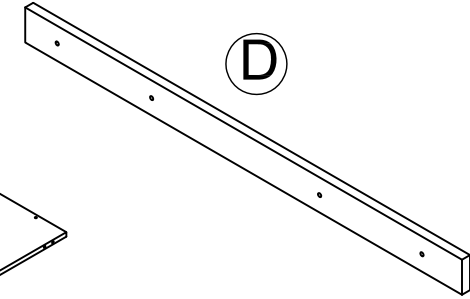

**D**  
BOTTOM RAIL (2)  
Riel Base (2)  
RAIL INFÉRIEUR (2)  
T1781096040

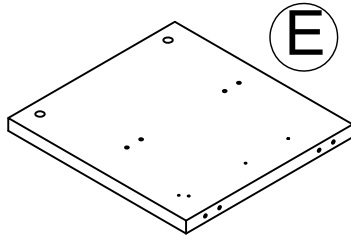

**E**  
LEFT SIDE PANEL  
Panel lateral izquierdo  
PANNEAU GAUCHE  
T1781096050

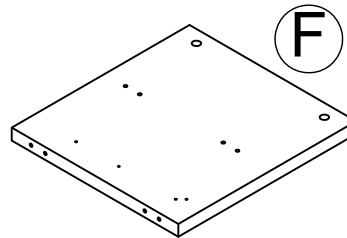

**F**  
RIGHT SIDE PANEL  
Panel lateral derecho  
CLOISON DROITE  
T1781096060

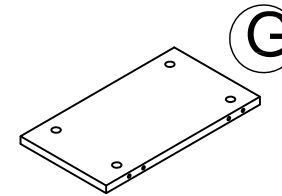

**G**  
UPPER PARTITION (2)  
Partición superior (2)  
CLOISON SUPÉRIEUR (2)  
T1781096070

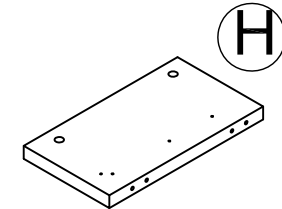

**H**  
LOWER PARTITION  
Partición inferior  
CLOISON INFÉRIEUR  
T1781096080

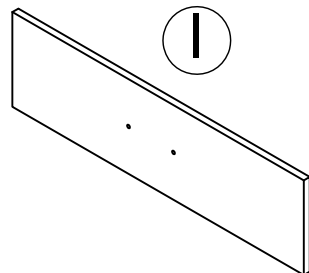

**I**  
LEFT DRAWER FRONT  
Frente del cajón izquierdo  
DEVANT DE TIROIR GAUCHE  
T1781096090

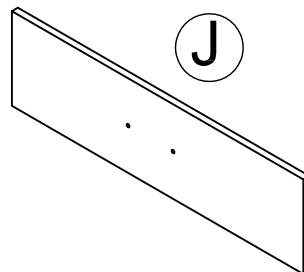

**J**  
RIGHT DRAWER FRONT  
Frente del cajón derecho  
DEVANT DE TIROIR DROIT  
T1781096100

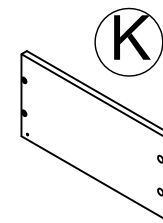

**K**  
LEFT DRAWER SIDE (2)  
Lado izquierdo del cajón (2)  
CÔTÉ GAUCHE DU TIROIR (2)  
T1781096110

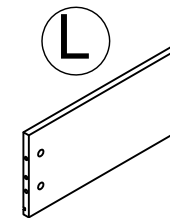

**L**  
RIGHT DRAWER SIDE (2)  
Lado derecho del cajón (2)  
CÔTÉ DROIT DU TIROIR (2)  
T1781096120

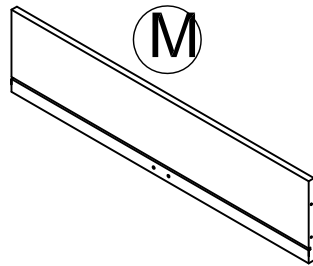

DRAWER BACK (2)  
Panel trasero del cajón (2)  
DOS DE TIROIR (2)  
T1781096130

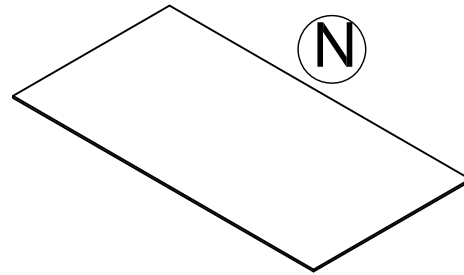

DRAWER BOTTOM (2)  
Fondo del cajón (2)  
FOND DU TIROIR (2)  
T1781096140

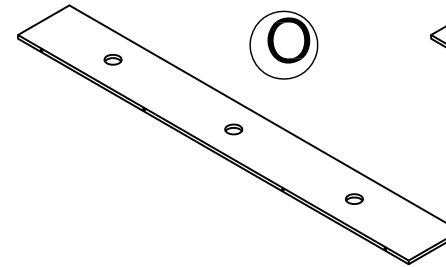

UPPER BACK PANEL  
Panel trasero superior  
PANNEAU ARRIÈRE SUPÉRIEUR  
T1781096050

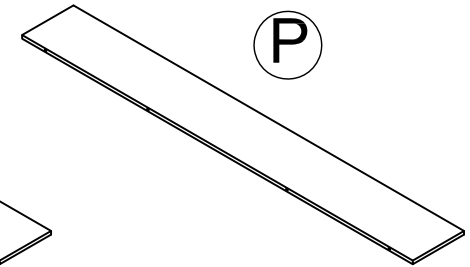

LOWER BACK PANEL  
Panel trasero inferior  
PANNEAU ARRIÈRE INFÉRIEUR  
T1781096160

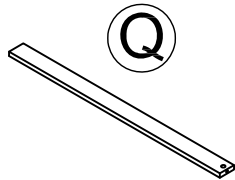

DRAWER SUPPORT  
Soporte de cajón  
SUPPORT DU TIROIR  
T1781096170  
QTY: 2PCS

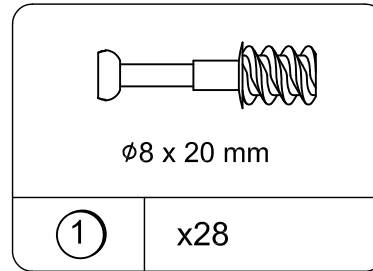

CAM BOLT  
Tornillo de rosca  
BOULON DE CAME  
TIV2011

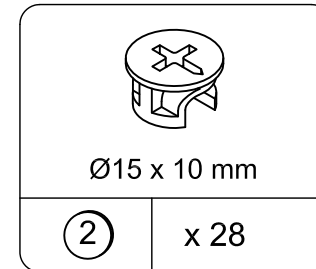

CAM LOCK  
Tornillo de cerradura  
SERRURE DE CAME  
TIV2010

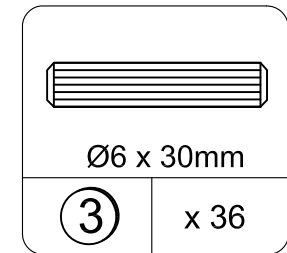

WOOD DOWEL  
Clavija de madera  
GOUJON EN BOI  
TIV3001

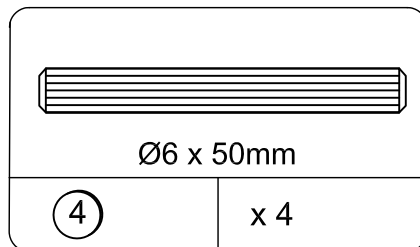

WOOD DOWEL  
Clavija de madera  
GOUJON EN BOI  
TIV3002

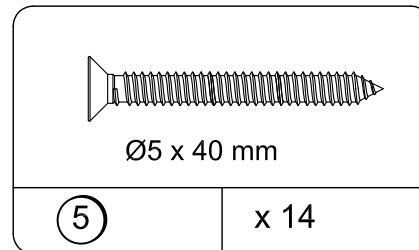

SCREW  
Tornillo  
VIS  
TIV1028

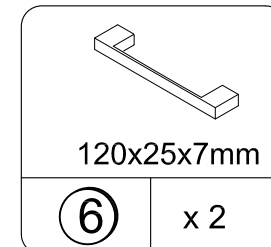

HANDLE  
Manija  
POIGNÉE  
TIV5503

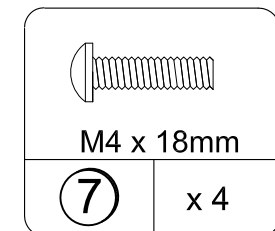

BOLT  
Perno  
BOULON  
TIV1005

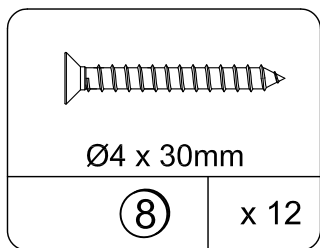

SCREW  
Tornillo  
VIS  
TIV1024

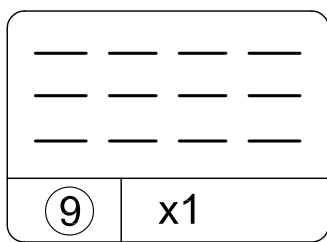

WARNING LABEL  
ETIQUETA DE ADVERTENCIA  
AVERTISSEMENT ÉTIQUETTE  
TIV4403

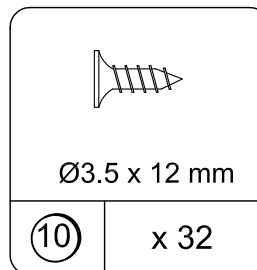

SCREW  
Tornillo  
VIS  
TIV1004

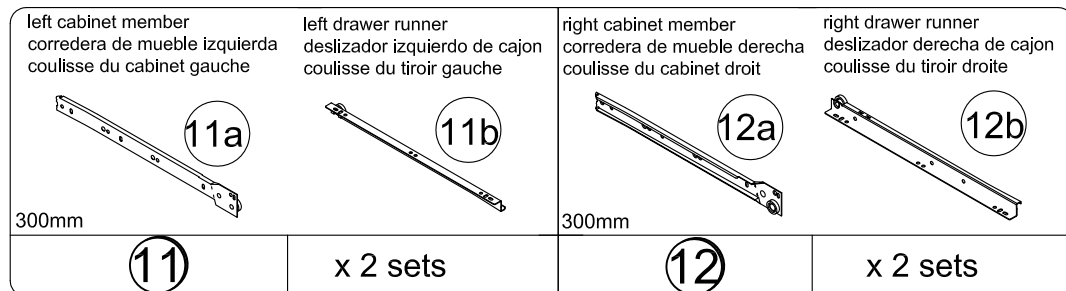

METAL SLIDE  
Riel de metal  
GLISSIÈRE EN MÉTA  
TIV4004

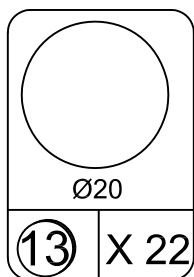

COVER  
Cubierta  
TIV2205

This illustration shows how the CAM fastening system works.

La ilustración muestra la fijación apropiada del seguro de la cerradura.

Cette illustration montre comment fonctionne le système de fixation de la CAME.

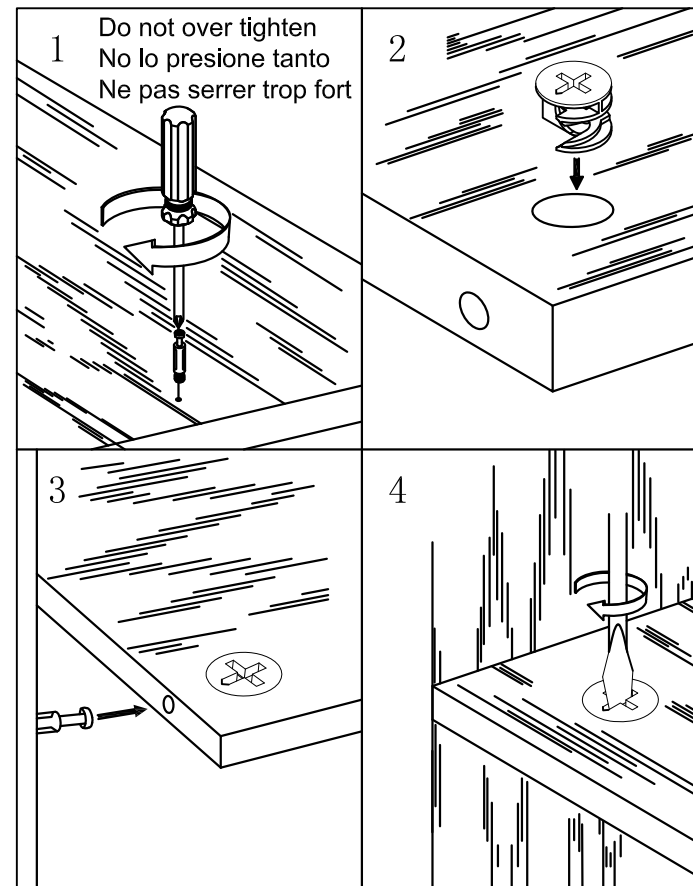

To view a video on how the CAM fastening system works, download a free QR-reader on your smartphone, then scan the code.

Mirar el video sobre cómo funciona el sistema de seguro de la leva, bajar gratis el QR del documento por el teléfono y, a continuación, escanear el código.

Pour voir une vidéo sur le fonctionnement du système de fixation de la CAME, téléchargez l'application gratuite QR-reader sur votre téléphone intelligent et numérisez le code.



# 1

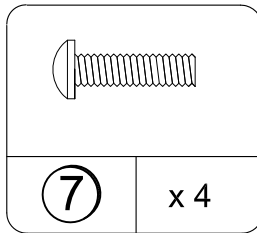
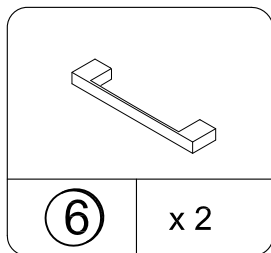
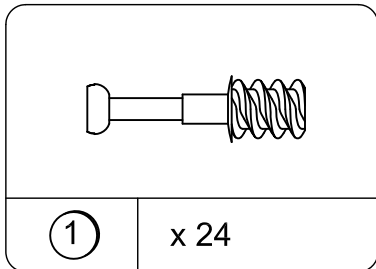
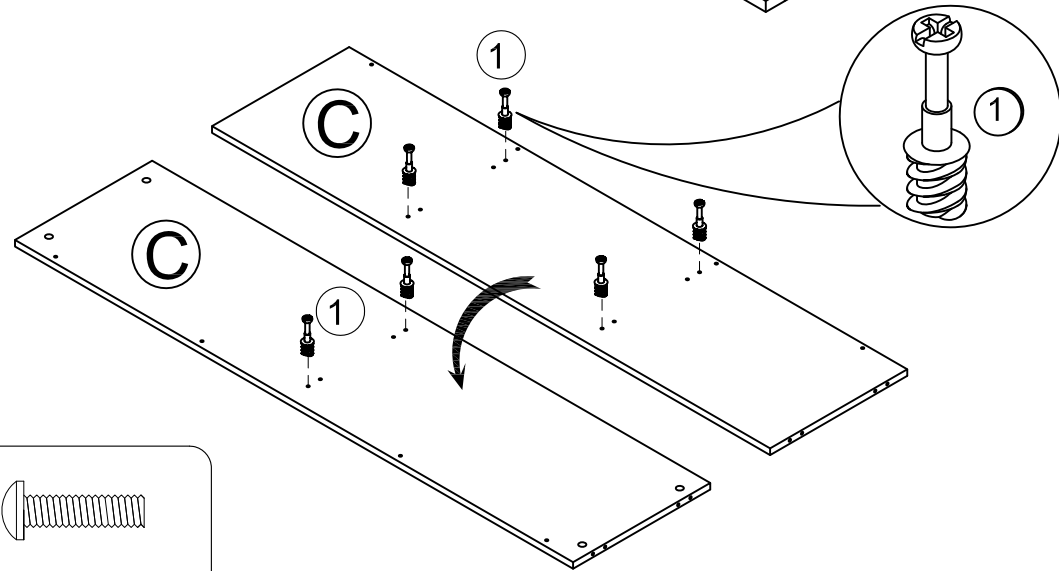
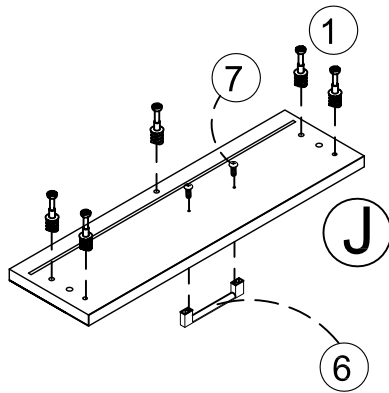
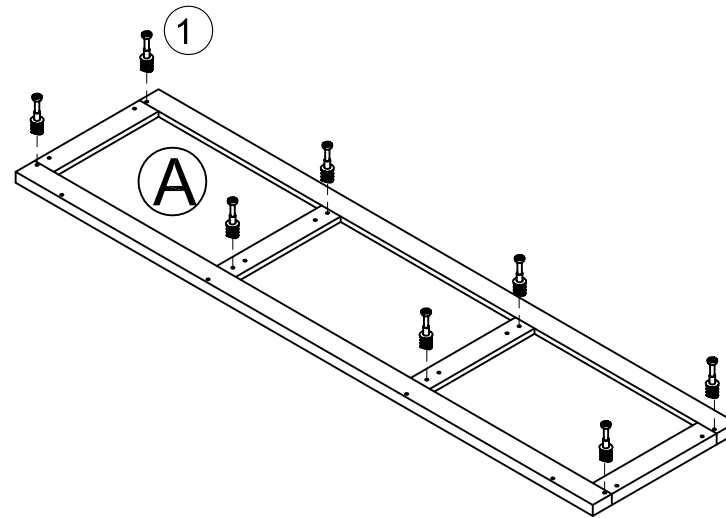
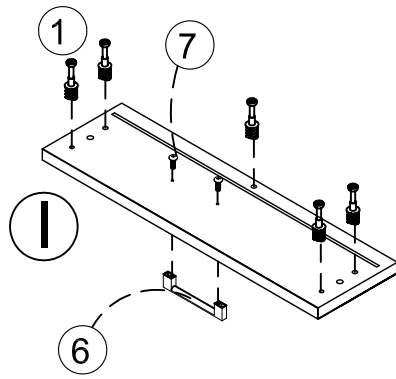

# 2

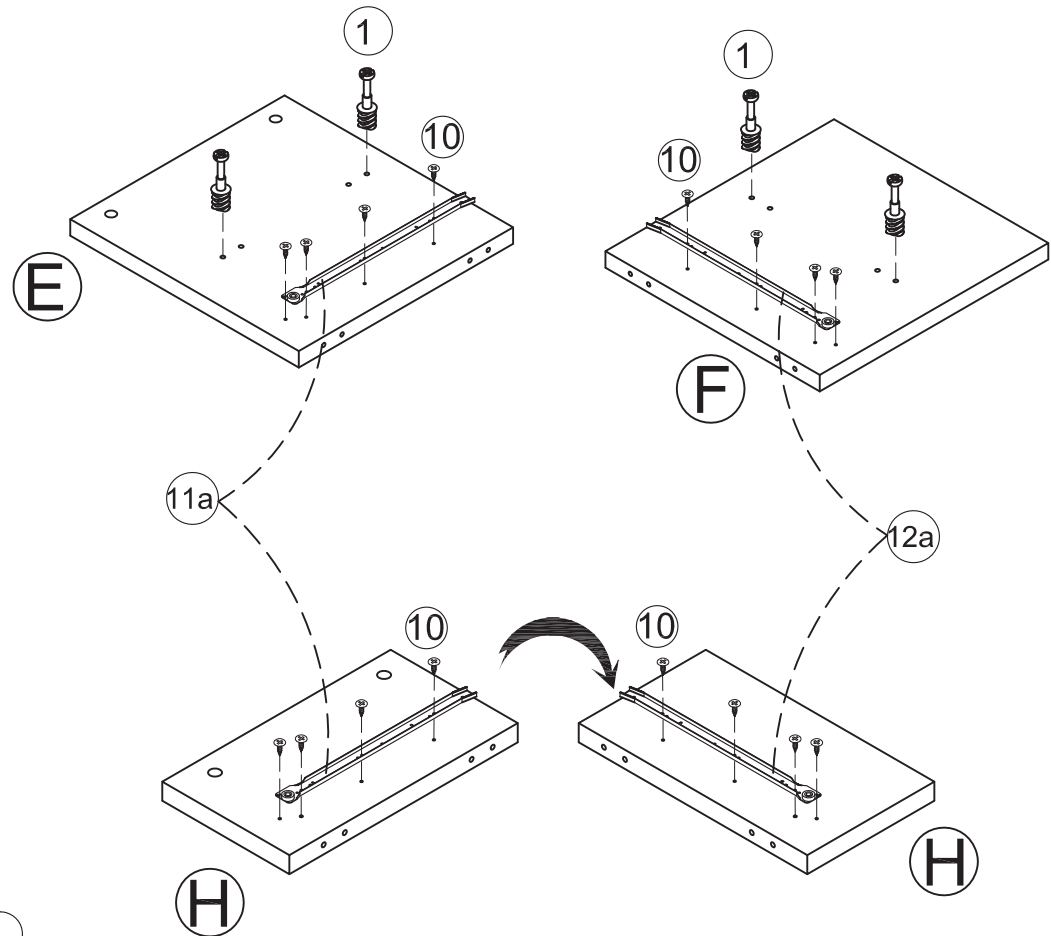
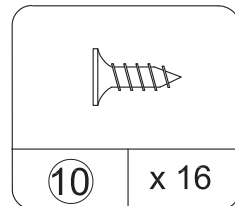
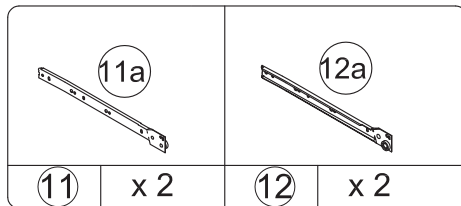
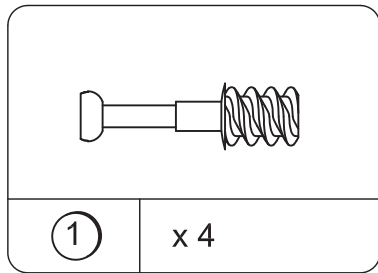
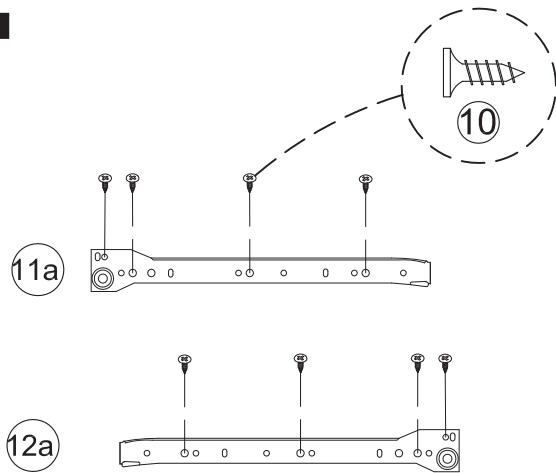

# 3

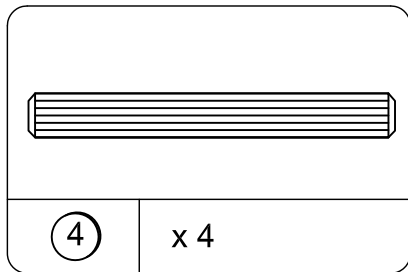
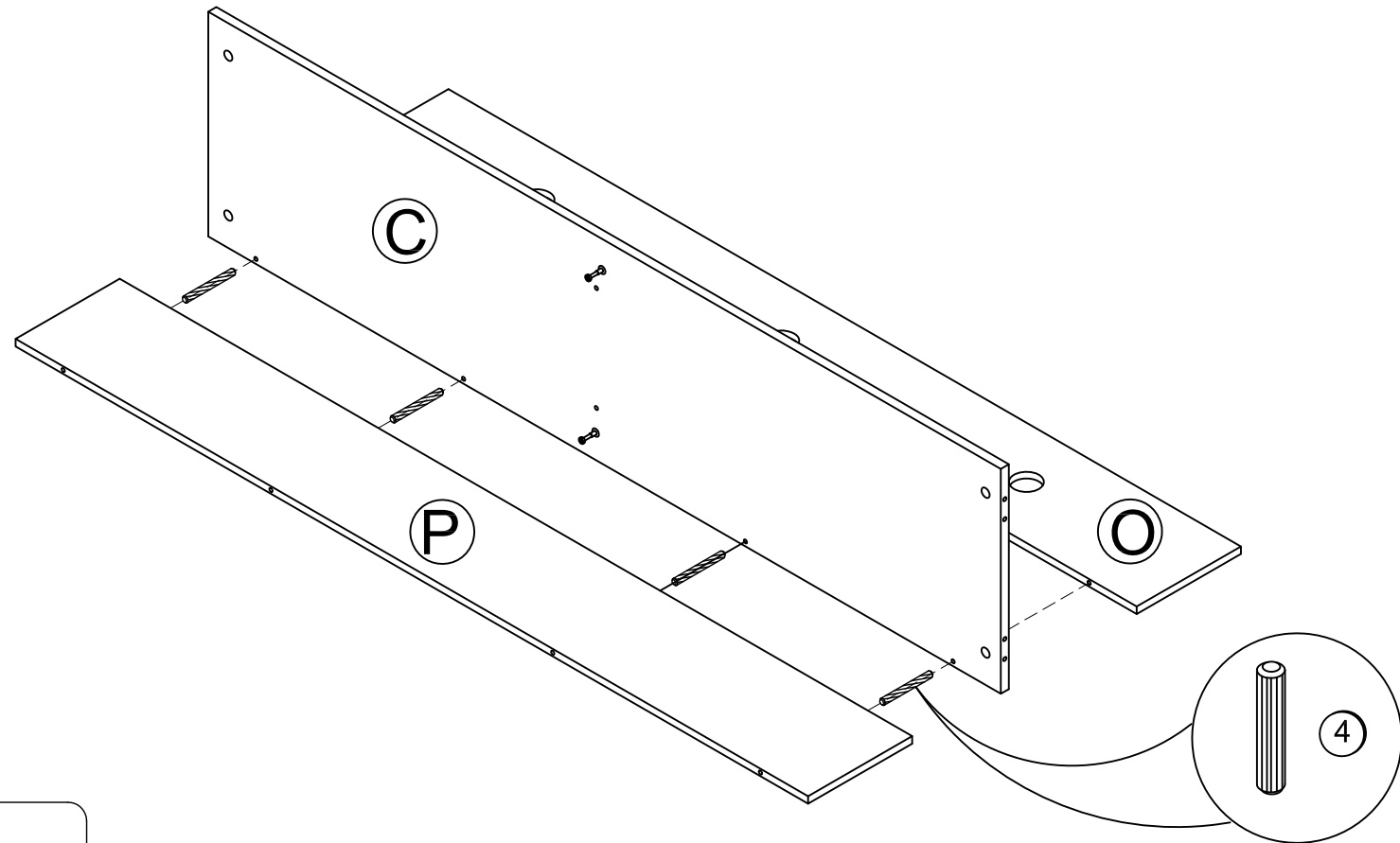



# 4

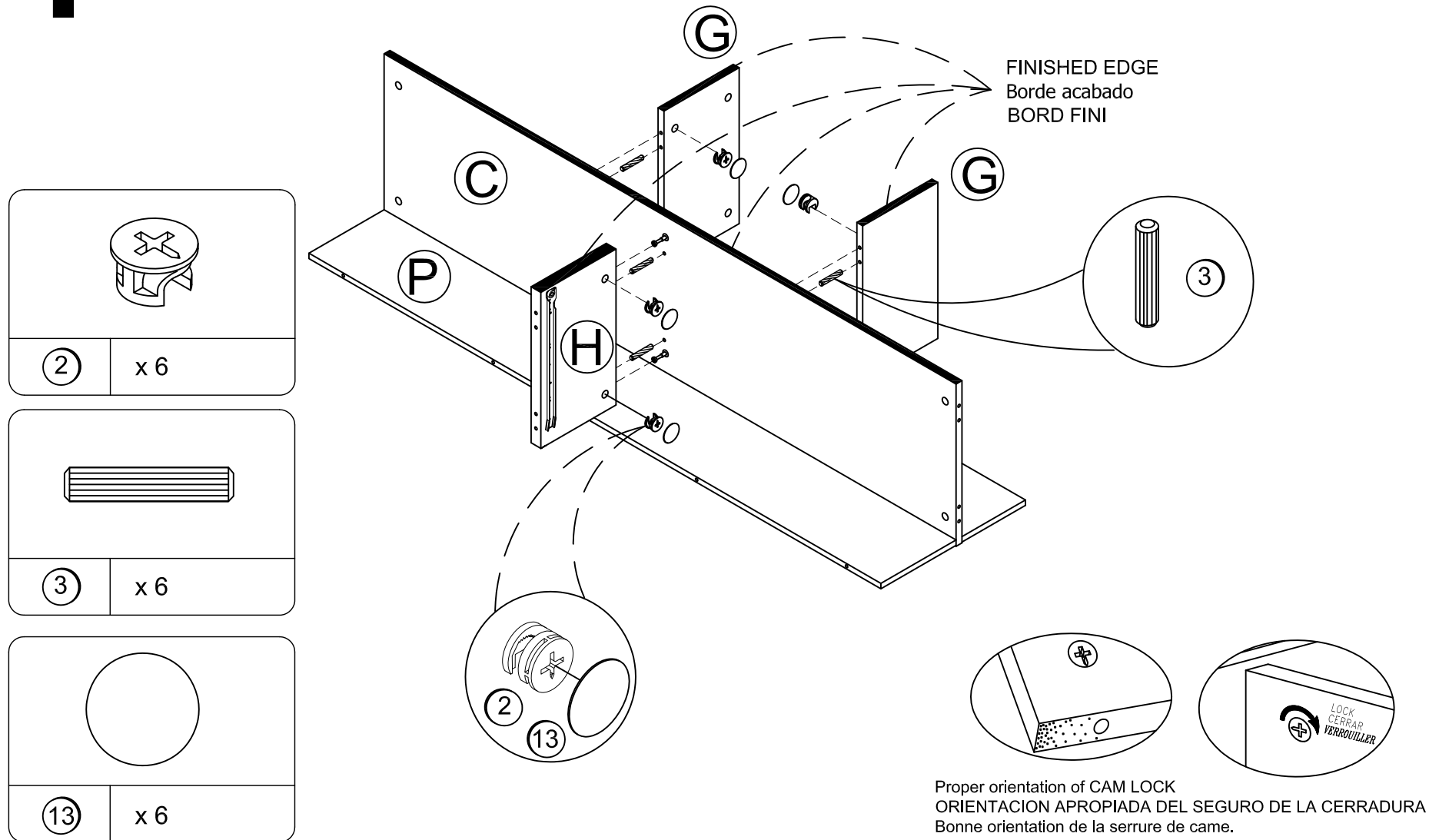

# 5

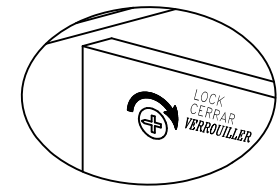
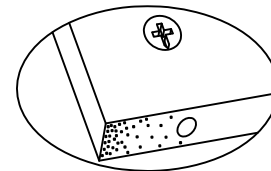
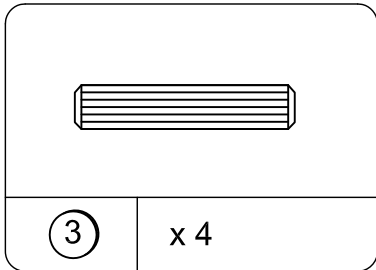
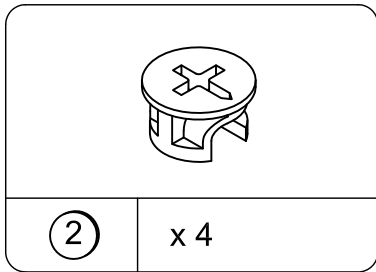
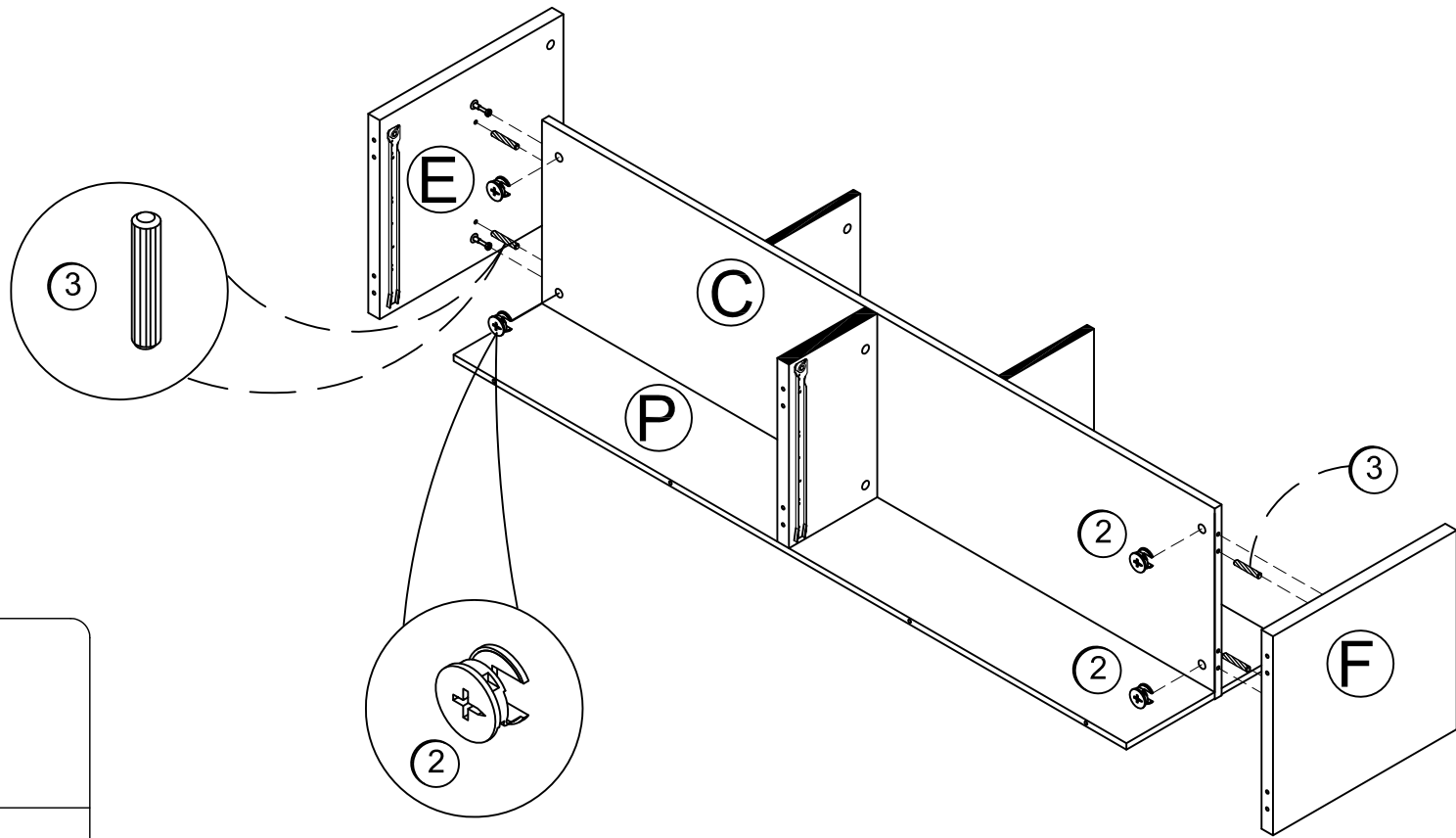

Proper orientation of CAM LOCK  
ORIENTACION APROPIADA DEL SEGURO DE LA CERRADURA  
Bonne orientation de la serrure de came.

# 6

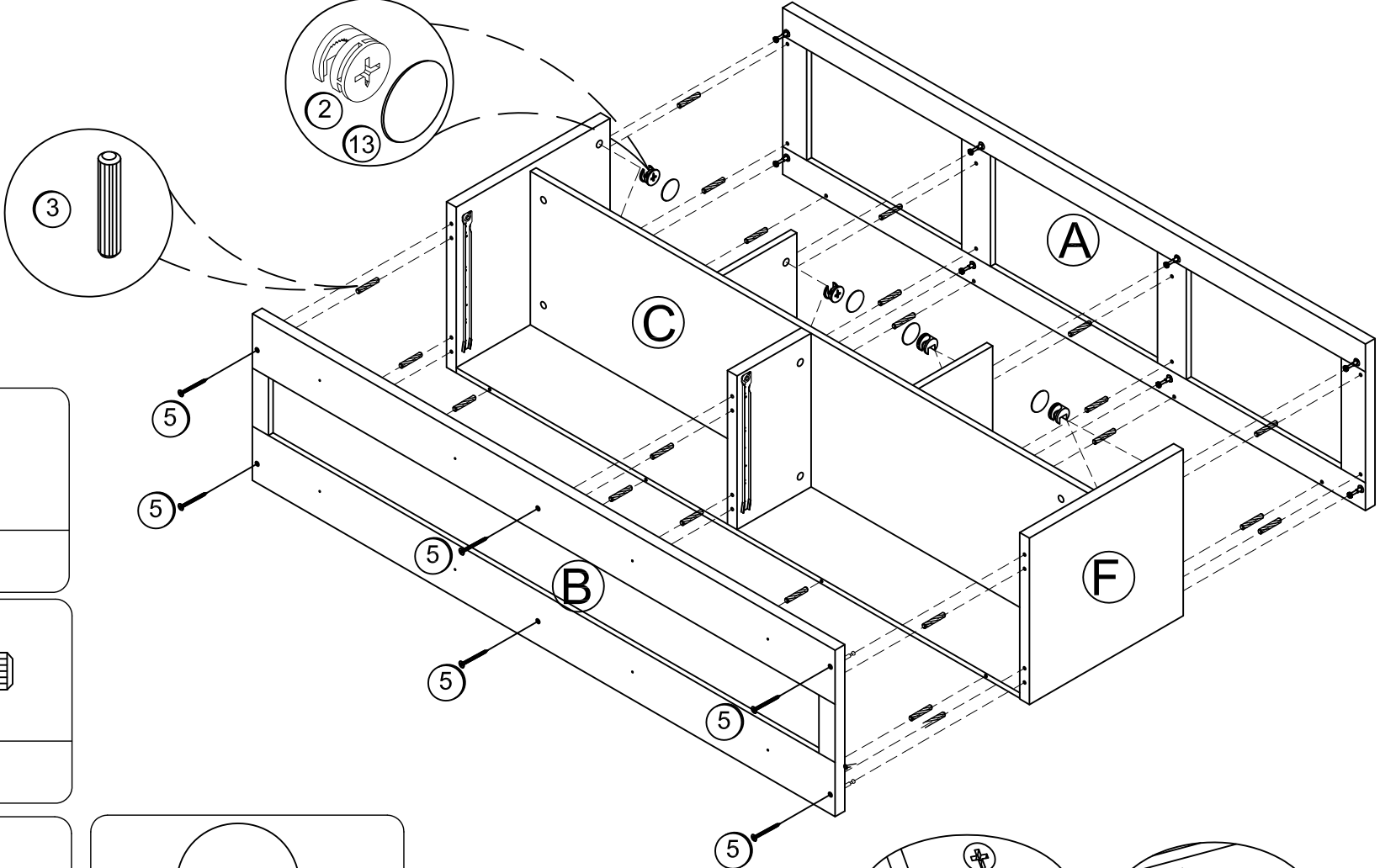

②	x 8

③	x 22

⑤	x 6

⑬	x 8

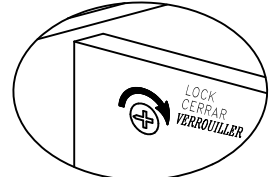
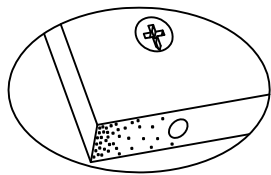

Proper orientation of CAM LOCK  
ORIENTACION APROPIADA DEL SEGURO DE LA CERRADURA  
Bonne orientation de la serrure de came.

# 7

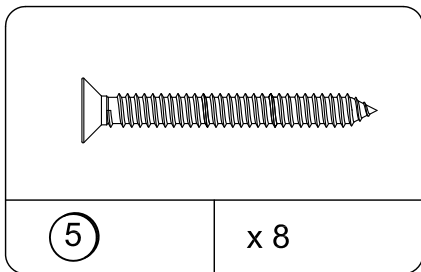
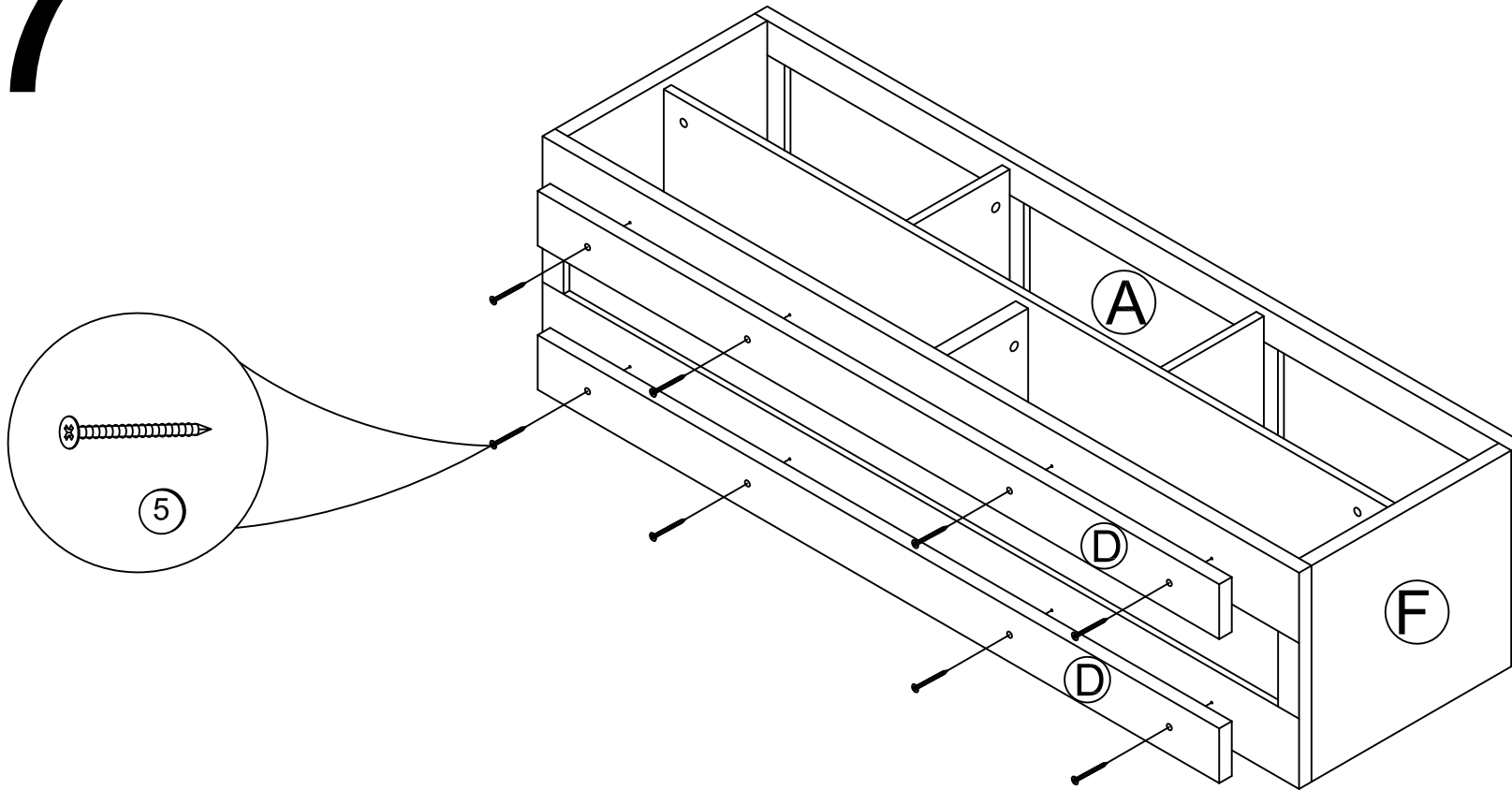

# 8

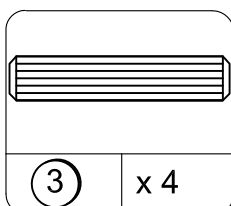
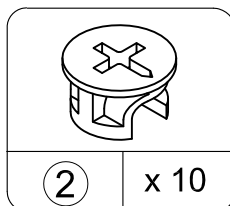
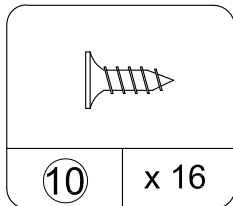
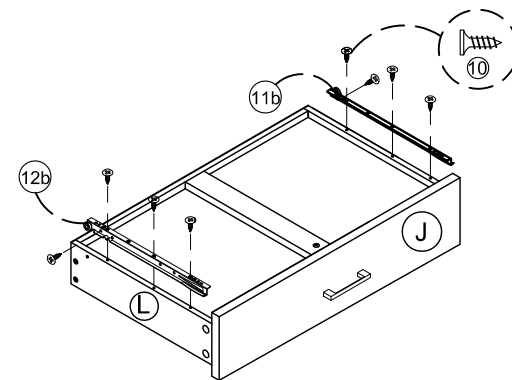
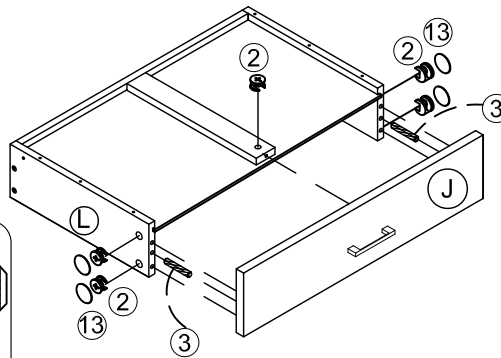
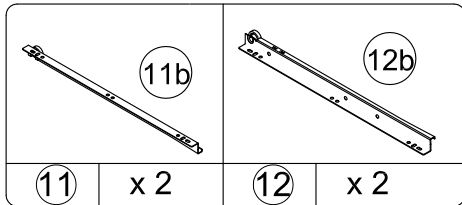
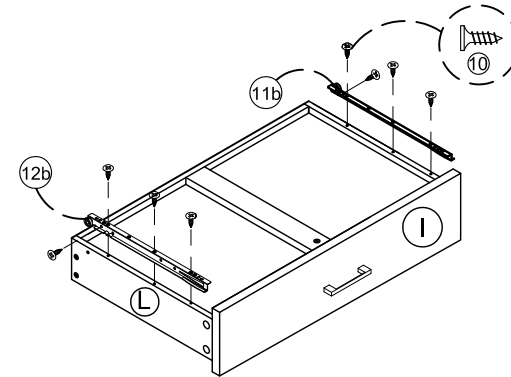
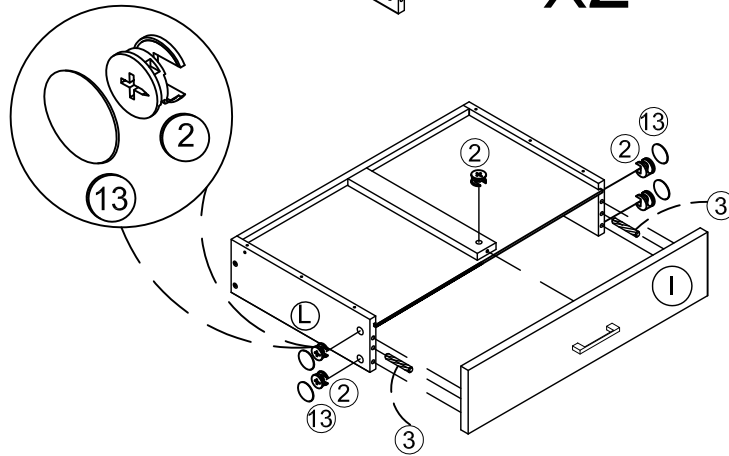
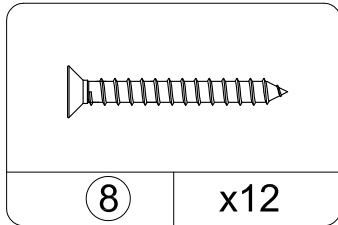
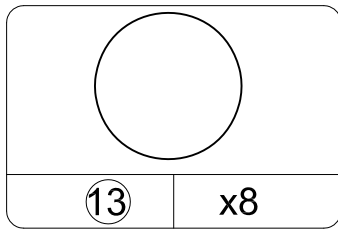
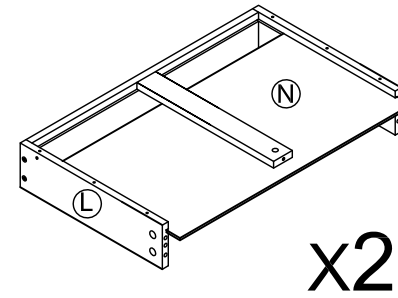
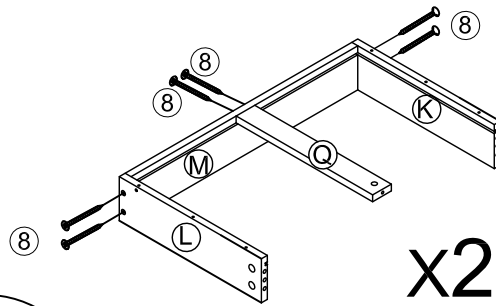

# 9

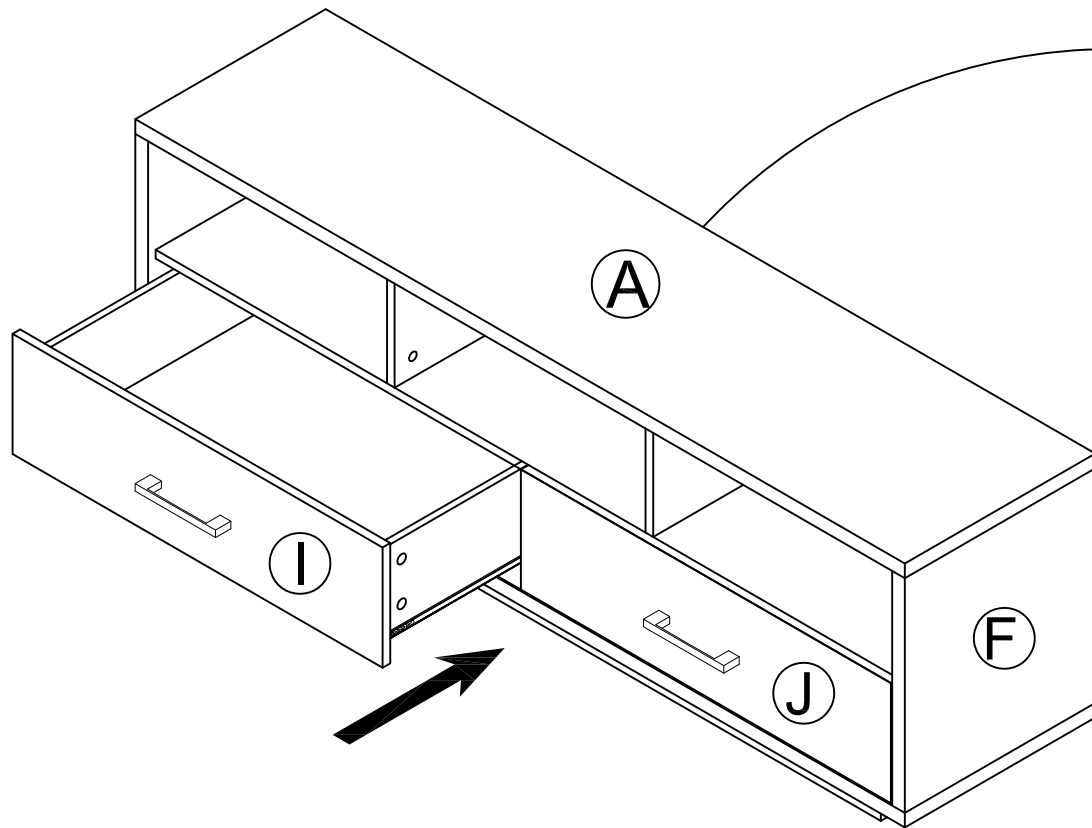

## REAR TIP WARNING LABEL

Risk of death or serious injury. This surface must be placed against a fixed in place wall at least as tall as television.

## ETIQUETA DE ADVERTENCIA DE PUNTA TRASERA

Riesgo de muerte o lesión. Esta unidad debe ser colocada frente a una pared y debe ser instalada por lo menos a la misma altura que una televisión.

## ÉTIQUETTE DE MISE EN GARDE - BASCULEMENT ARRIÈRE

Danger de mort ou de blessures graves. Cette surface doit être placée contre un mur fixé en place au moins aussi grand que la télévision.

# 10

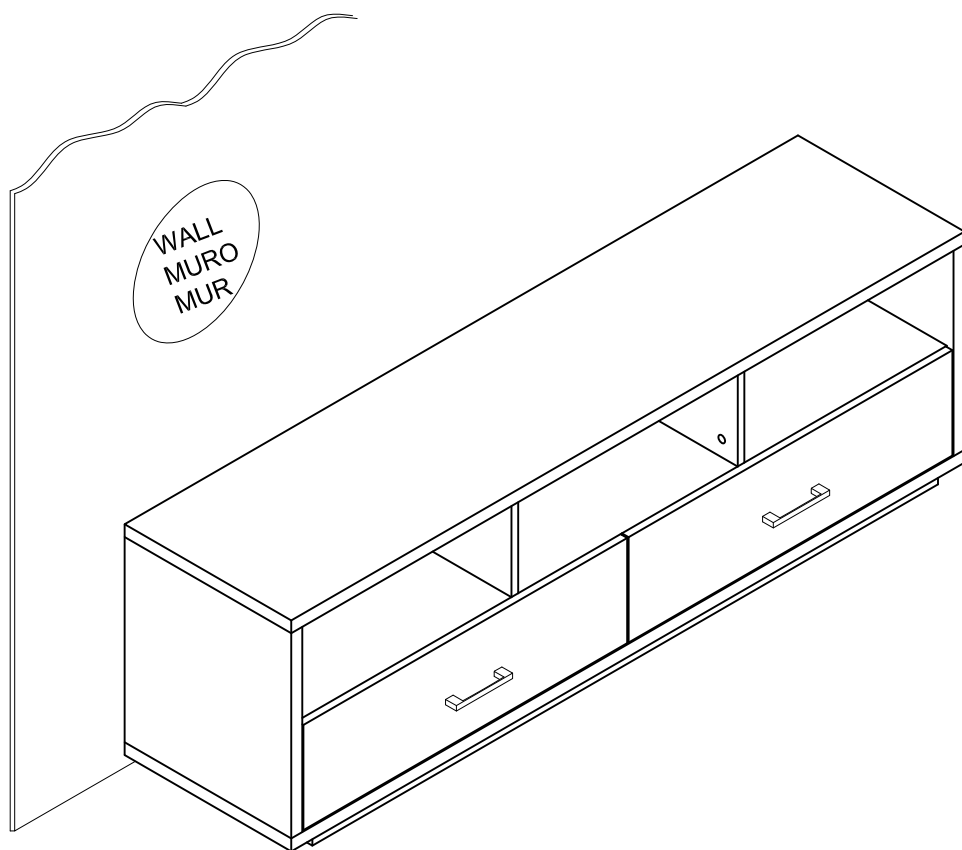

## **WARNING**

Risk of death or serious injury. This unit must be placed against a fixed in place wall at least as tall as television.

## **ADVERTENCIA**

Riesgo de muerte o lesión. Esta unidad debe ser colocada frente a una pared y debe ser instalada por lo menos a la misma altura que una televisión.

## **AVERTISSEMENT**

Danger de mort ou de blessures graves. Cette surface doit être placée contre un mur fixé en place au moins aussi grand que la télévision.

WEIGHT LIMITS :  
LIMITES DE PESO :  
LIMITES DE POIDS :

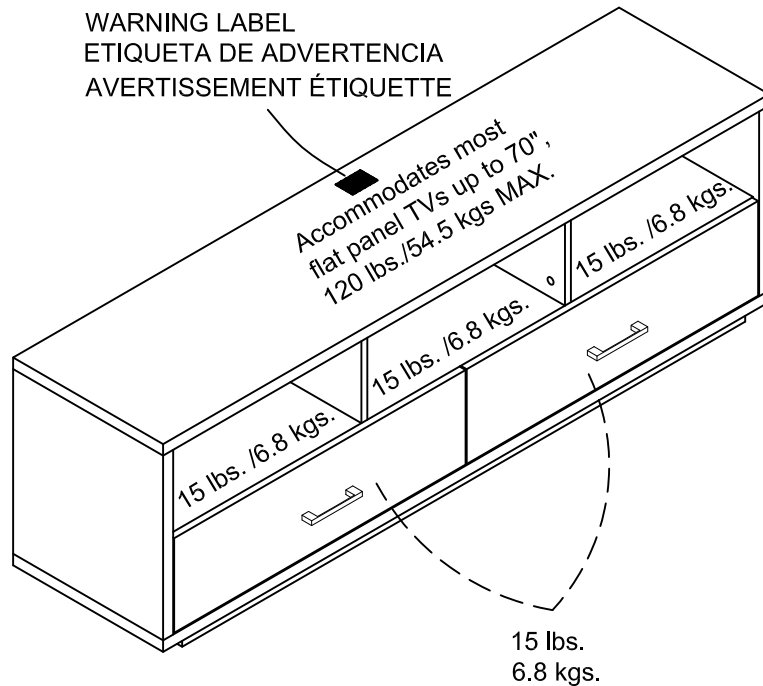

Enjoy your furniture.  
Disfrute de su mueble.  
Profitez de votre meuble.

This unit has been designed to support the maximum loads shown. Exceeding these load limits could cause sagging, instability, product collapse, and/or serious injury.

Esta unidad ha sido diseñada para soportar una carga máxima como se muestra. Excederse en los límites de cargas o sobre peso puede ocasionar inestabilidad, flacidez, y el derrumbamiento del mueble y ocasionar lesiones

Ce meuble a été conçu pour soutenir les charges maximum indiquées. Si ces limites sont dépassées, le meuble peut fléchir, devenir instable, s'effondrer et causer des blessures graves.

**▲ WARNING**

Please make sure that all the objects are removed before moving the assembled unit. The unit must be lifted by more than one person, not dragged or pushed. Failure to do so will cause product damage, instability, product collapse, and/or serious injury.

**▲ ADVERTENCIA**

Por favor, asegúrese de que todos los objetos sean removidos antes de mover la unidad ensamblada. La unidad debe ser levantada por más de una personas no arrastrada o empujada. No hacerlo podría causar la destrucción del mueble, inestabilidad y provocar severas lesiones.

**▲ AVERTISSEMENT**

Veillez vous assurer d'enlever tous les objets du meuble avant de le déplacer. Le meuble doit être soulevé en équipe et non traîné ou poussé. Si vous ne respectez pas cette directive, le meuble peut se briser, devenir instable, s'effondrer et entraîner des blessures graves.