

# 4 PIECE CONVERSATION SET

## ENSEMBLE DE CONVERSATION 4 PIÈCES

### JUEGO DE CONVERSACIÓN DE 4 PIEZAS

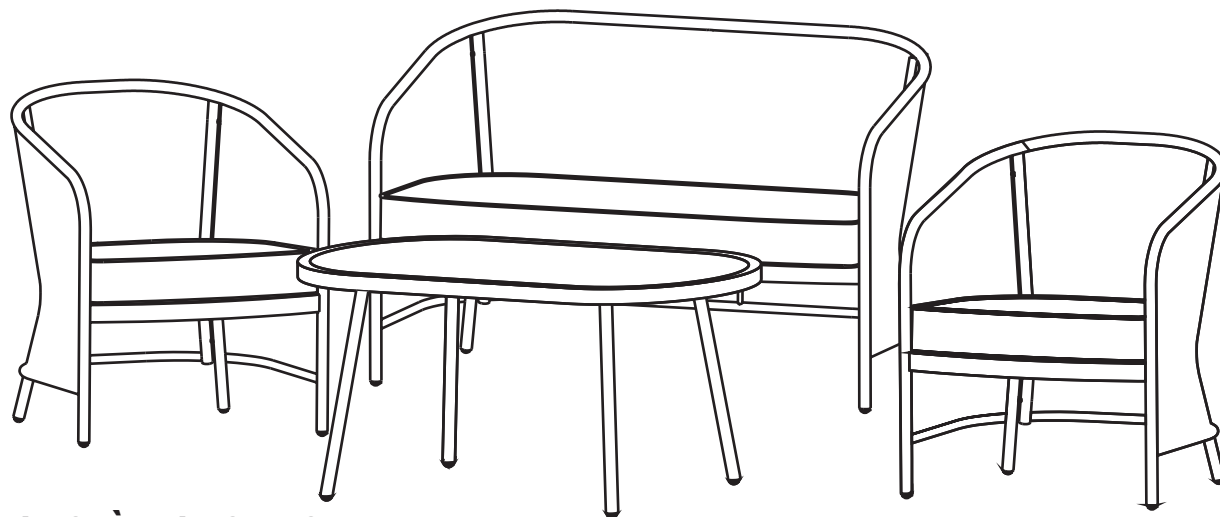

MODEL / MODÈLE / MODELO #88212

## ASSEMBLY INSTRUCTIONS

## INSTRUCTIONS D'ASSEMBLAGE

## INSTRUCCIONES DE ENSAMBLAJE



### READ & SAVE BELOW INSTRUCTIONS BEFORE ASSEMBLY

1. Please separate and identify all parts, making sure that you have all of the parts listed.
2. To avoid any scratches during assembly, please assemble on a soft mat or similar.
3. Follow step by step instructions.
4. Do not tighten screws until all the screws and washers are properly installed.
5. Tighten screws securely, do not over-tighten.



### LIRE & CONSERVER LES INSTRUCTIONS CI-DESSOUS AVANT D'ASSEMBLER

1. Séparez et identifiez toutes les pièces, en vous assurant d'avoir toutes les pièces indiquées.
2. Pour éviter les rayures pendant l'assemblage, veuillez assembler sur une carpeite douce ou une surface similaire.
3. Suivez les instructions étape par étape.
4. Ne pas serrer les vis jusqu'à ce que toutes les vis et les rondelles soient installées correctement.
5. Serrez les vis solidement, ne pas serrer excessivement.



### GUARDAR Y LEER INSTRUCTIONS ANTES DE ARMAR

1. Por favor separe e identifique todas las partes, asegurándose que tiene todas las piezas indicadas.
2. Para evitar cualquier rasguño durante la asamblea, favor de armar sobre una superficie suave.
3. Siga las instrucciones paso por paso.
4. No apretar los tornillos hasta que todos los tornillos y las arandelas hayan sido instalados.
5. Apretar los tornillos seguramente, no apretar en exceso.

## CARE AND CLEANING:

1. To clean, wipe with damp cloth. Do not use bleach, acid, solvents or abrasive cleaners.
2. Please do not put any transparent glassy substance or similar on the unit to avoid potential sunlight focusing damage.
3. During varying weather conditions and winter period, we strongly recommend that the unit be stored in a dry area with a suitable cover before storage, please ensure the unit is clean and dry.
4. Do not stand or climb on unit.







## SOIN ET ENTRETIEN:

1. Pour nettoyer, essuyez avec un chiffon humide. Ne pas utiliser d'eau de javel, de solvants acides ou de nettoyants abrasifs.
2. S.V.P. Ne pas mettre de substance vitrée transparente ou autre chose similaire sur le meuble afin d'éviter des dommages potentiels causés par le soleil.
3. Lors de conditions météorologiques changeantes et pendant l'hiver, nous recommandons fortement d'entreposer le meuble dans un endroit sec recouvert d'une couverture appropriée. Avant d'entreposer, S.V.P. Veuillez vous assurer que le meuble est propre et sec.
4. Ne pas monter ou grimper sur le meuble.

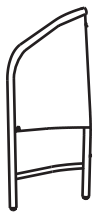



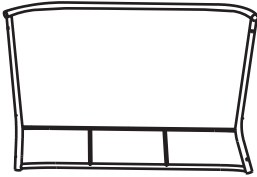



## GUIDADO Y LIMPIEZA:

1. Para limpiar, limpie con un paño húmedo. No utilice blanqueador, disolventes acidos o limpiadores abrasivos.
2. Favor de no ponga ninguna substancia vidriosa transparente o similar en la unidad para evitar daño potencial de enfoque de la luz del sol.
3. Durante condiciones de clima variables y periodos de invierno, recomendamos firmemente que la unidad sea guardada en una area seca con una cobertura adecuada. Antes de guardar, favor de asegurar que la unidad esté limpia y seca.
4. No se pare o suba en la unidad.

### PARTS / LES PIÈCES / PARTES

PART PARTIE PARTE	IMAGE IMAGEN IMAGE	DESCRIPTION DESCRIPTION DESCRIPCIÓN	QTY. QTÉ. CANT.
<b>A</b>		Right Side Côté Droit Derecho	<b>3</b>
<b>B</b>		Left Side Côté Gauche Izquierda	<b>3</b>
<b>C</b>		Chair Back Dossier de Chaise Trasero de Silla	<b>2</b>
<b>D</b>		Chair Seat Siège de Chaise Asiento de Silla	<b>2</b>
<b>E</b>		Loveseat Back Dossier de Causeuse Trasero	<b>1</b>
<b>F</b>		Loveseat Seat Siège De Causeuse Soporte	<b>1</b>

### PARTS / LES PIÈCES / PARTES

PART PARTIE PARTE	IMAGE IMAGEN IMAGE	DESCRIPTION DESCRIPTION DESCRIPCIÓN	QTY. QTÉ. CANT.
<b>G</b>		Chair Cushion Coussin de Chaise Cojín de Silla	<b>2</b>
<b>H</b>		Loveseat Cushion Coussin De Causeau Cojín	<b>1</b>
<b>I</b>		Table Leg Pied De Table Pata De La Mesa	<b>4</b>
<b>J</b>		Table Top Dessus de la Table Mesa	<b>1</b>
<b>AA</b>			<b>12</b>
<b>BB</b>			<b>25</b>
<b>CC</b>			<b>1</b>
<b>DD</b>			<b>37</b>

**Tighten all the screws to 60% first, then tighten to 100% once fully assembled.**

**Serrez toutes les vis à 60% d'abord puis serrez à 100% une fois complètement assemblées.**

**Apriete todos los tornillos al 60% primero y luego apriete al 100% una vez que esté completamente ensamblado.**

# CHAIR ASSEMBLY / ASSEMBLAGE DE LA CHAISE / MONTAJE DE LA SILLA

**1.**

Attach parts **C** and **D** with **BB** (x2).  
 Attachez les pièces **C** et **D**, utilisant **BB** (x2).  
 Fije las piezas **C** y **D**, usando **BB** (x2).

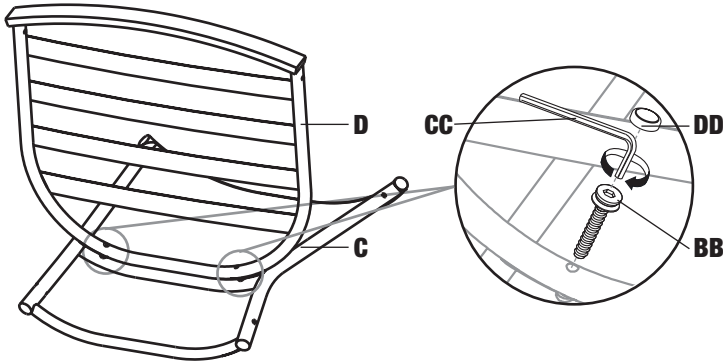

**2.**

Attach part **A** to parts **C/D** with **BB** (x3).  
 Attachez la pièce **A** aux pièces **C/D**, utilisant **BB** (x3).  
 Fije la pieza **A** a las piezas **C/D**, utilizando **BB** (x3).

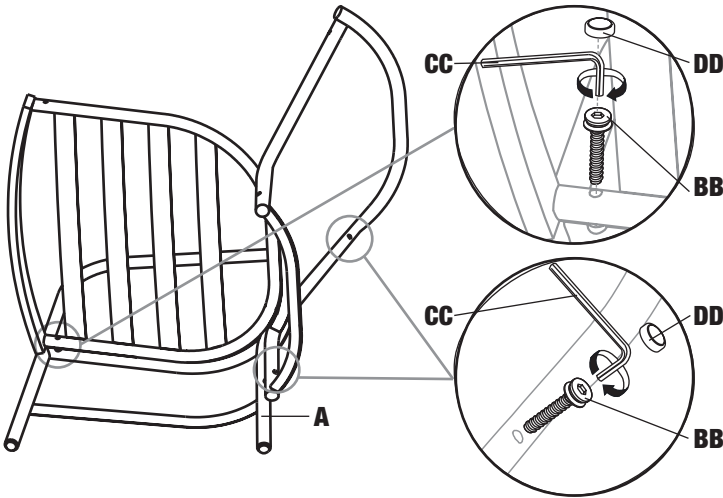

**3.**

Attach part **B** to parts **C/D** with **BB** (x3).  
 Attachez la pièce **B** aux pièces **C/D**, utilisant **BB** (x3).  
 Fije la pieza **B** a las piezas **C/D**, utilizando **BB** (x3).

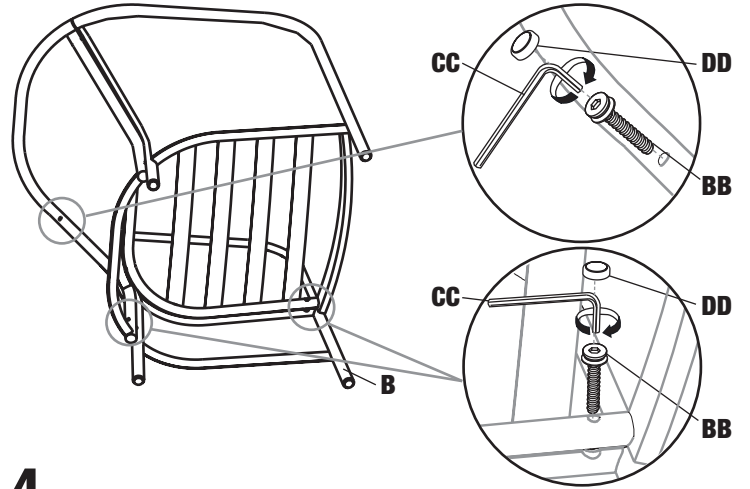

**4.**

Place part **G** on seat.  
 Placez la pièce **G** sur la si ge.  
 Coloque la pieza **G** en el asiento.

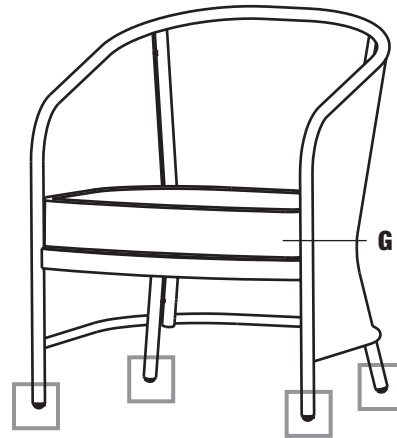

# TABLE ASSEMBLY / ASSEMBLAGE DES TABLES / MONTAJE DE LA MESA

**1.**

Attach parts **I** to part **J** using **AA** (x12).  
 Attachez les pi ces **I**   la pi ce **J**, utilisant **AA** (x12).  
 Fije las piezas **I** a la pieza **J**, usando **AA** (x12).

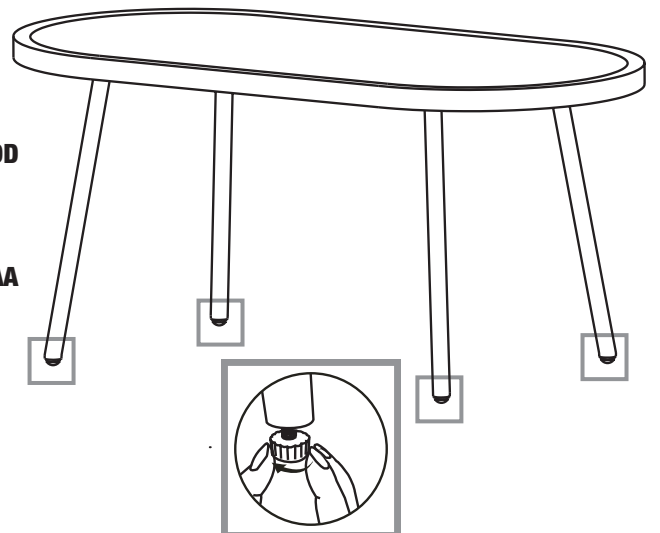
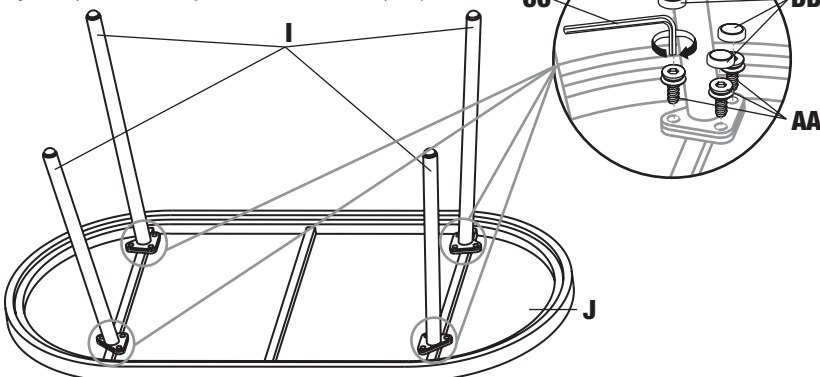

# LOVE SEAT ASSEMBLY / ASSEMBLAGE DE CAUSEUSE / MONTAJE DEL SOFÁ DE DOS PLAZAS

**1.**

Attach parts **E** and **F** with **BB** (x3).

Attachez les pièces **E** et **F**, utilisant **BB** (x3).

Fije las piezas **E** y **F**, usando **BB** (x3).

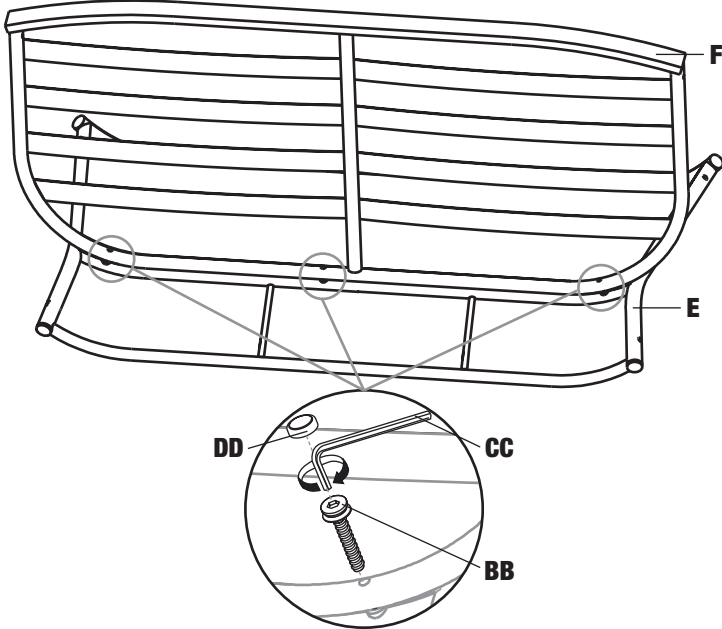

**3.**

Attach part **B** to parts **E/F** with **BB** (x3).

Attachez la pièce **B** aux pièces **E/F**, utilisant **BB** (x3).

Fije la pieza **B** a las piezas **E/F**, usando **BB** (x3).

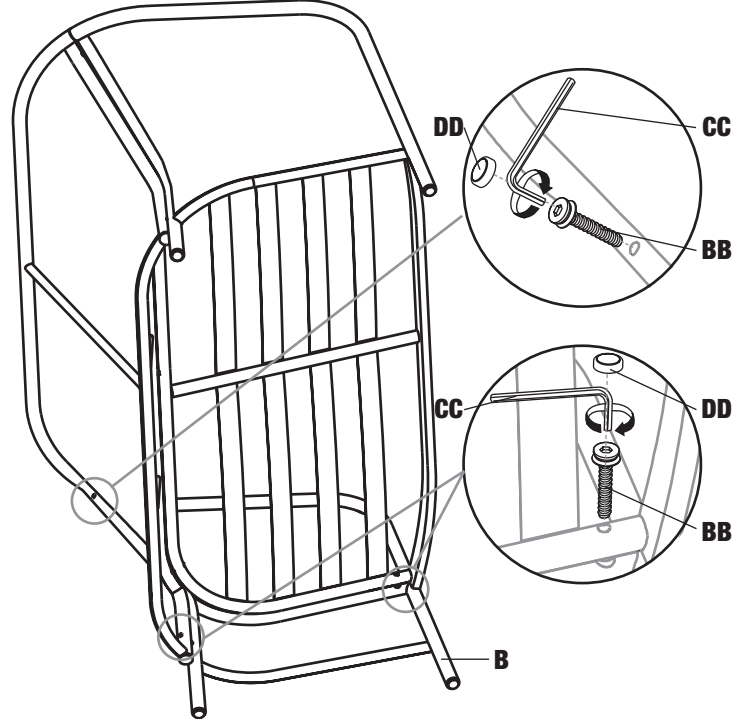

**2.**

Attach part **A** to parts **E/F** with **BB** (x3).

Attachez la pièce **A** aux pièces **E/F**, utilisant **BB** (x3).

Fije la pieza **A** a las piezas **E/F**, usando **BB** (x3).

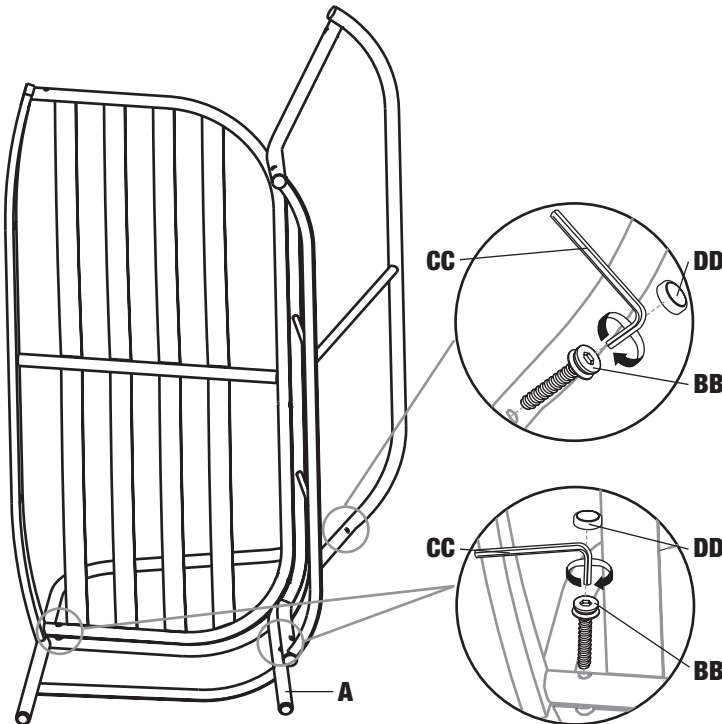

**4.**

Place part **H** on the seat.

Placez la pièce **H** sur la siégle.

Coloque la pieza **H** en el asiento.

