

- 4354306COM (FEDERAL WHITE)
- 4354335COM (NIGHTFALL OAK)

**NOV  
OGR  
ATZ**

# Full Wall Bed

B344354000COM1

Date of Purchase \_\_\_ / \_\_\_ / \_\_\_  
Lot Number:

**WARNING:**

- \* **WARNING FOR YOUNG CHILDREN -**  
This product contains small components, please ensure that they are kept away from small children. Children under the age of 6, small infants and babies must not sleep on this bed for safety reasons. To prevent injury and damage to this unit, PROHIBIT jumping on it.
- \* This product is designed for home use and not intended for commercial use.

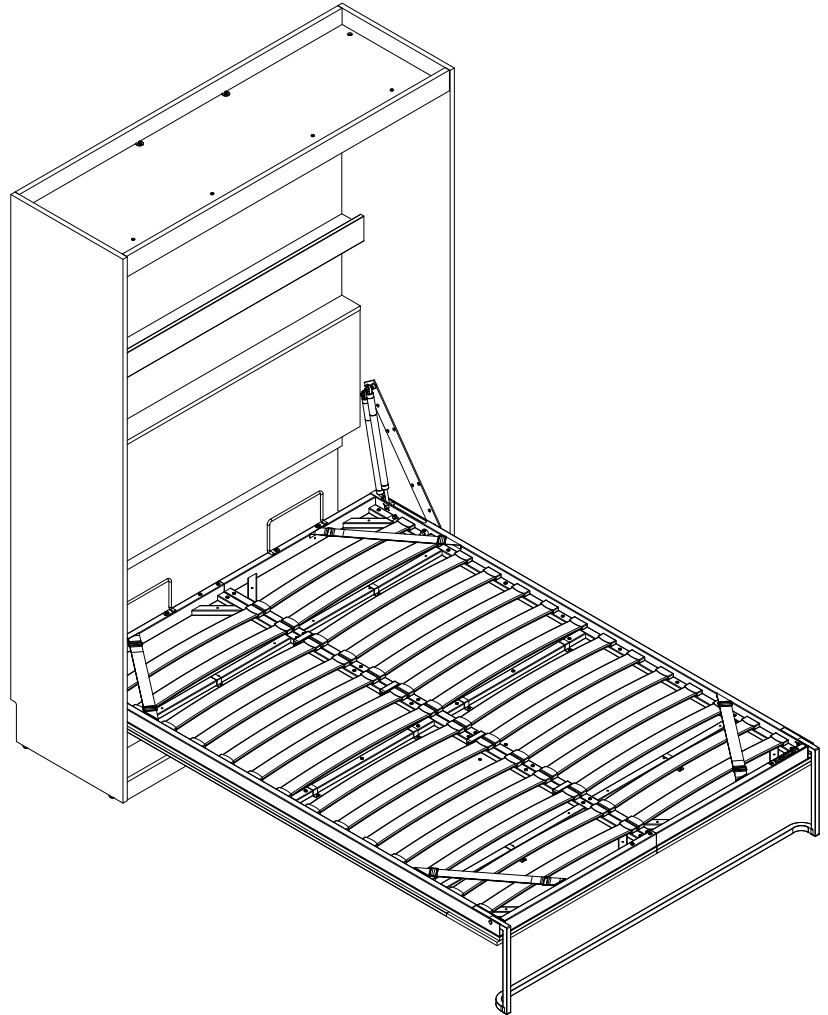

**Do Not Return This Product!**

Contact our customer service team for help first.

**Call:** 1-800-489-3351 (toll free)

**Visit:** [www.ameriwoodhome.com](http://www.ameriwoodhome.com)

THIS INSTRUCTION BOOKLET CONTAINS **IMPORTANT** SAFETY INFORMATION. PLEASE READ AND KEEP FOR FUTURE REFERENCE.

**Professional installation is required for this unit.**



**WARNING**

- Unit can tip over causing severe injury or death.
- Anchor unit to stud in wall
- Do Not allow children to climb on unit

Follow Ameriwood Home



# Contact Us!

## Do NOT return this product!

Contact our friendly customer service team first for help.

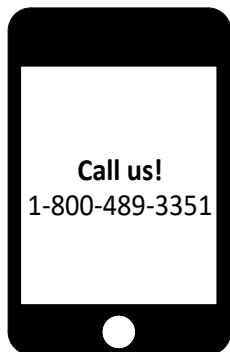

Visit [ameriwoodhome.com](http://ameriwoodhome.com) to view the limited warranty valid in the U.S. and Canada.

Assembly Tips



# Helpful Hints

PEOPLE NEEDED FOR ASSEMBLY: 2

- Open your item in the area you plan to keep it to avoid excessive heavy lifting.



- Identify, sort and count the parts before attempting assembly.



- Make sure to always face the point on the top of the Cam Lock towards the outer edge.

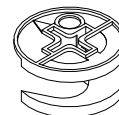

- Do NOT use harsh chemicals or abrasive cleaners on this item.



- Never push, pull, or drag your furniture.



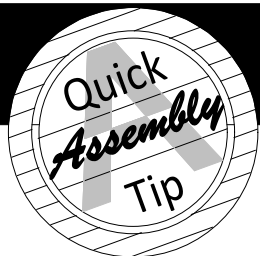

# Before You Start

- ✓ Read through each step carefully and follow the proper order
- ✓ Separate and count all your parts and hardware  
Parts are labeled on the surface or edge of the part
- ✓ Give yourself enough room for the assembly process
- ✓ Have the following tools: Flat Head Screwdriver, #2 Phillips Head Screwdriver and Hammer
- ✓ Caution: If using a power drill or power screwdriver for screwing, please be aware to slow down and stop when screw is tight. Failure to do so may result in stripping the screw.

# Cam Lock Fastening System

This Cam Lock Fastening System will be used throughout the assembly process.

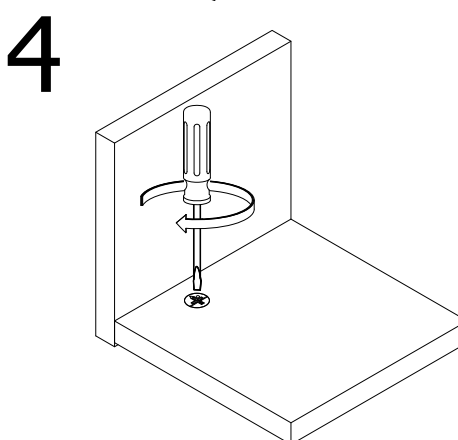
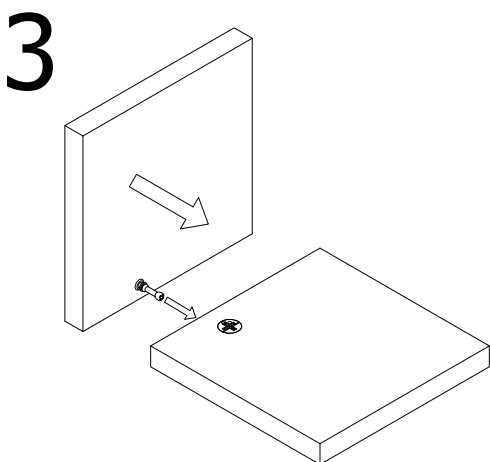
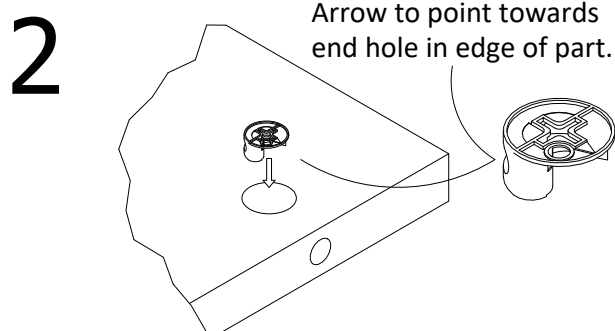
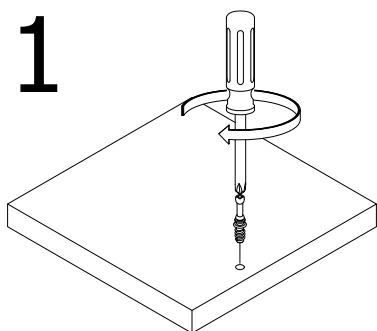

# Board Identification

Not actual size

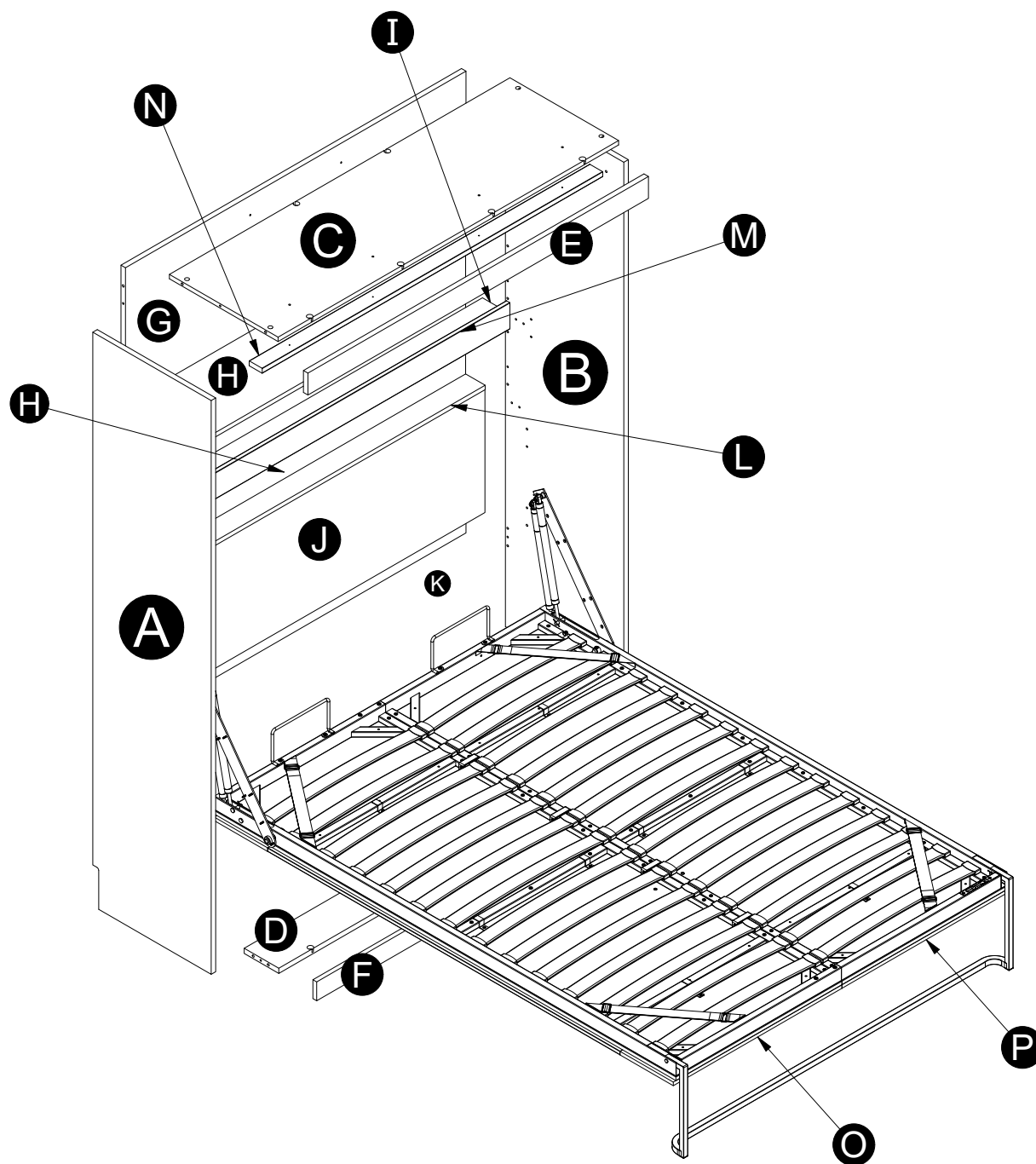

# Board Identification

## parts for 4354306COM (Federal White)

Parts List			
ITEM	QTY	PART NUMBER	DESCRIPTION
A	1	34354306010	LEFT PANEL
B	1	34354306020	RIGHT PANEL
C	1	34354306030	TOP
D	1	34354306040	BOTTOM
E	1	34354306050	VALANCE
F	1	34354306060	KICK
G	1	34354306070	UPPER BACK PANEL
H	2	34354306080	CENTER BACK PANEL
I	1	34354306090	UPPER SHELF
J	1	34354306100	HEADBOARD PANEL
K	1	34354306110	BOTTOM STRINGER
L	1	34354306120	LOWER SHELF
M	1	34354306130	SHELF RAIL
N	1	34354306140	STOP RAIL
O	1	34354306150	LEFT DOOR ASM
P	1	34354306160	RIGHT DOOR ASM

## parts for 4354335COM (Nightfall Oak)

Parts List			
ITEM	QTY	PART NUMBER	DESCRIPTION
A	1	34354335010	LEFT PANEL
B	1	34354335020	RIGHT PANEL
C	1	34354335030	TOP
D	1	34354335040	BOTTOM
E	1	34354335050	VALANCE
F	1	34354335060	KICK
G	1	34354335070	UPPER BACK PANEL
H	2	34354335080	CENTER BACK PANEL
I	1	34354335090	UPPER SHELF
J	1	34354335100	HEADBOARD PANEL
K	1	34354335110	BOTTOM STRINGER
L	1	34354335120	LOWER SHELF
M	1	34354335130	SHELF RAIL
N	1	34354335140	STOP RAIL
O	1	34354335150	LEFT DOOR ASM
P	1	34354335160	RIGHT DOOR ASM

Note that your unit may contain extra hardware

# Part List

Actual Size

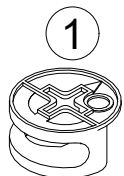

(x30)  
#A22620  
cam lock

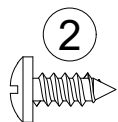

(x16)  
#A12105  
#8x7/16" pan head

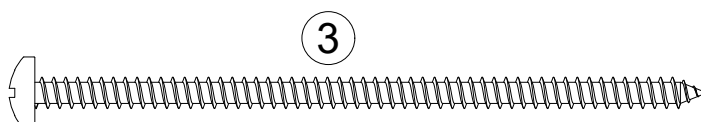

(x8)  
#A13950  
#8x3-1/2" pan head

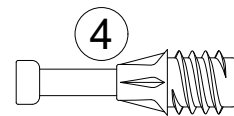

(x30)  
#A22610  
cam bolt

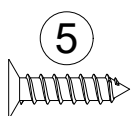

(x16)  
#A12400  
#8x5/8" flat head

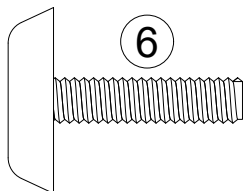

(x4)  
#A43020  
glide

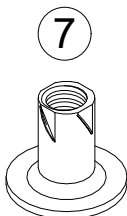

(x4)  
#A20330  
nut

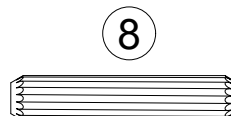

(x30)  
#A21660  
wood dowel

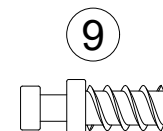

(x16)  
#A22910  
connector bolt

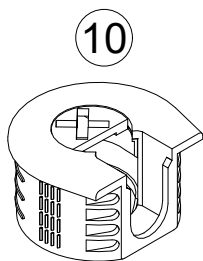

(x16)  
#A22920  
connector

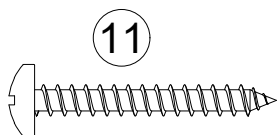

(x42)  
#A13020  
#8x1-1/4" pan head

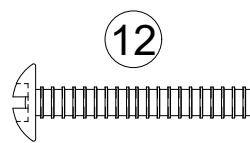

(x4)  
#A17630  
8-32 x 1-1/4" bolt

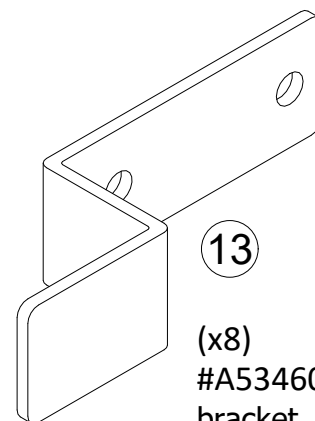

(x8)  
#A53460  
bracket

14

ATTENTION / ATENCION / ATTENTION

(x1)  
#B64481  
warning label

15

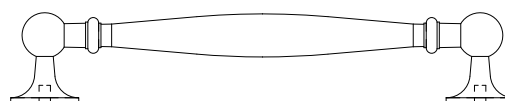

(x2)  
A50790  
handle

# Bed Frame Identification

Not Actual Size

**Note:**  
Not all parts will  
be identified.

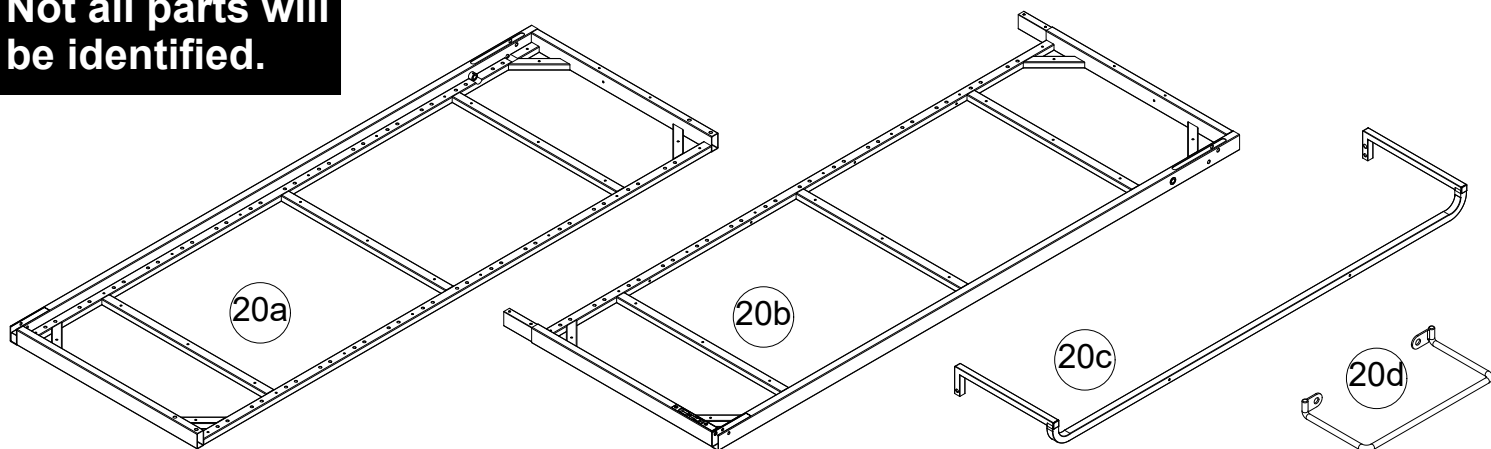

Left Assembly  
3678096-20a

Right Assembly  
3678096-20b

Leg  
3678096-20c

Mattress Holder (2)  
3678096-20d

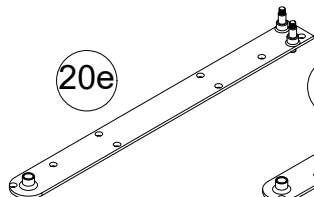

Left Pivot Arm  
3678096-20e

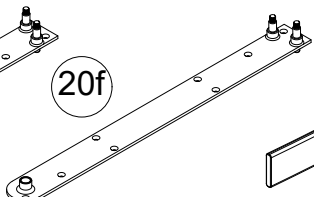

Right Pivot Arm  
3678096-20f

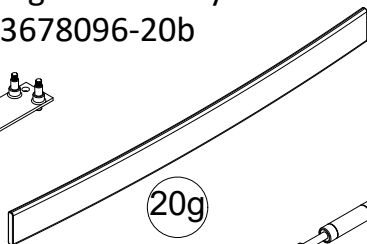

Wood Slat (28)  
3678096-20g

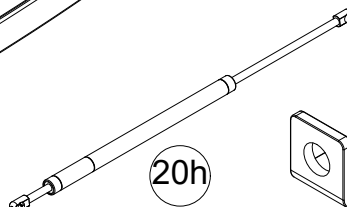

Gas Piston (4)  
3678096-20h

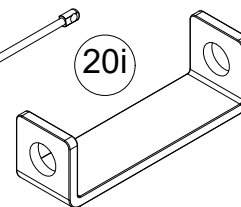

U-Bracket (4)  
3678096-20i

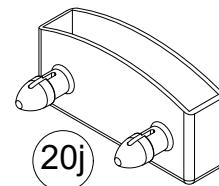

Plastic Cap (56)  
3678096-20j

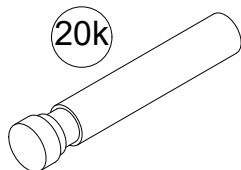

Pivot Pin (2)  
3678096-20k

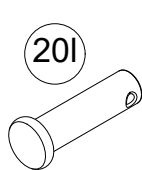

Large Clevis Pin (4)  
3678096-20l

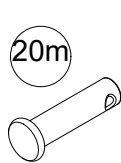

Small Clevis Pin (2)  
3678096-20m

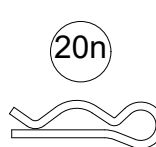

Cotter Pin (6)  
3678096-20n

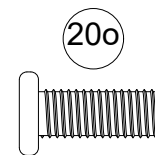

M6 x 16mm Bolt (12)  
3678096-20o

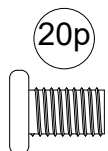

M6 x 10mm Bolt (6)  
3678096-20p

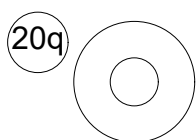

Washer (8)  
3678096-20q

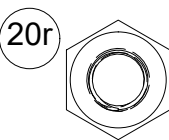

Hex Nut (4)  
3678096-20r

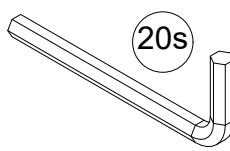

4mm Hex Key  
3678096-20s

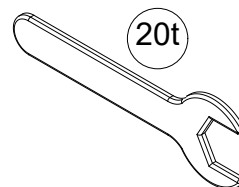

Wrench  
3678096-20t

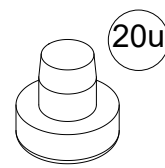

Rubber Foot (2)  
3678096-20u

# Before you start!

---

**NOV  
OGR  
ATZ**



**Caution: Failure to use 2 professionals for this assembly could result in unit damage or personal injury.**



# STEP 1

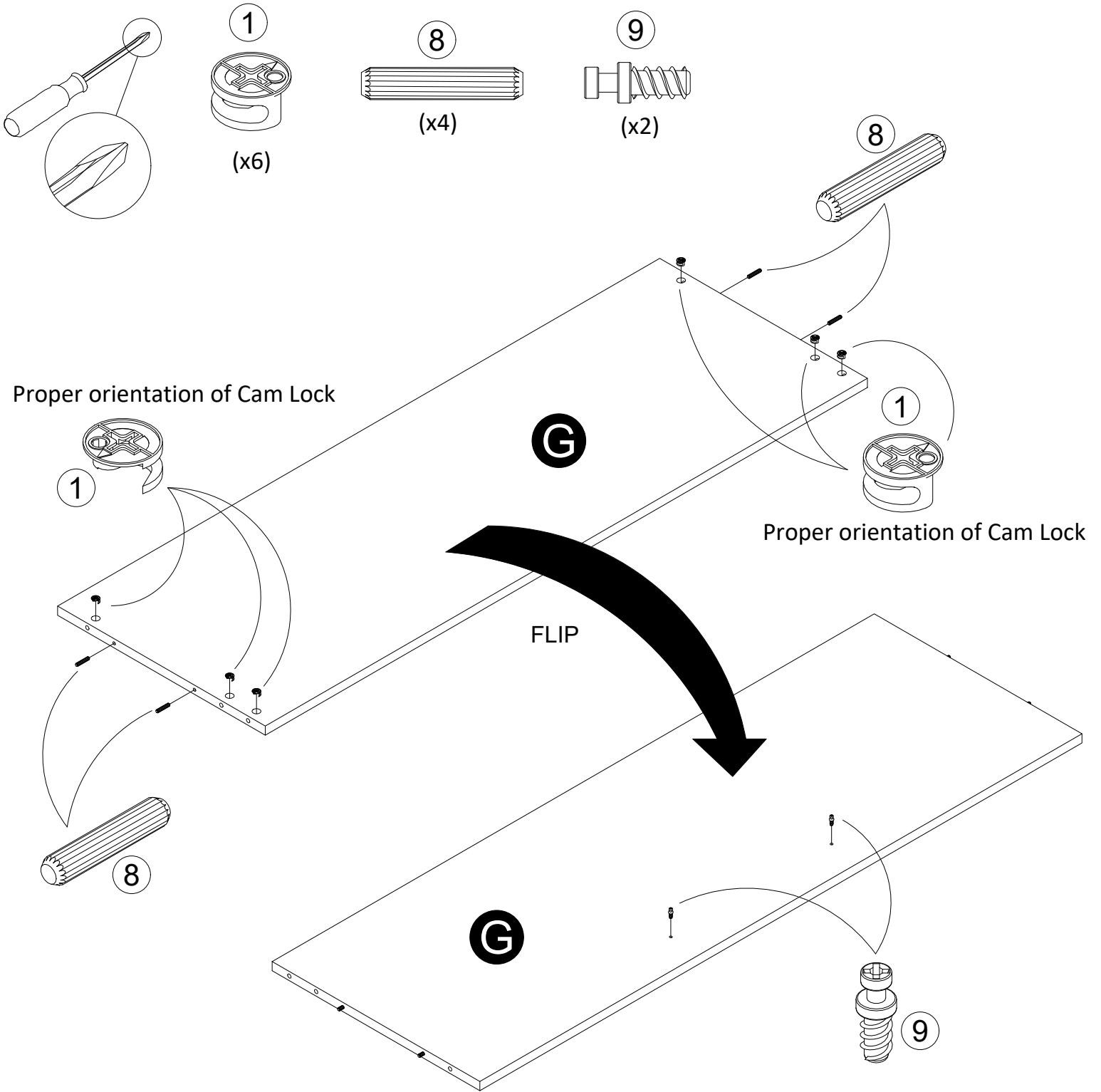

# STEP 2

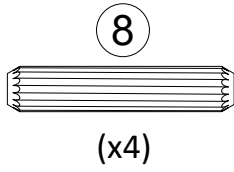

**x2**

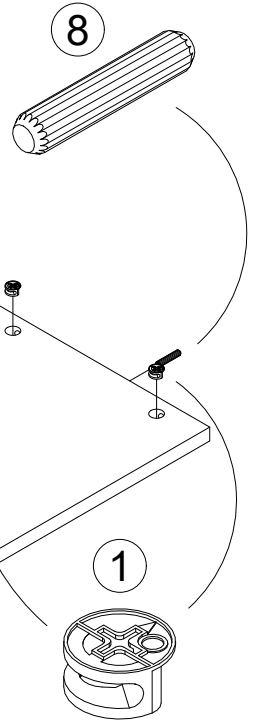

Proper orientation of Cam Lock



Proper orientation of Cam Lock

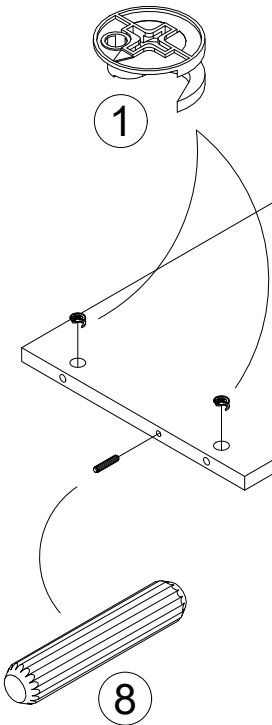

# STEP 3

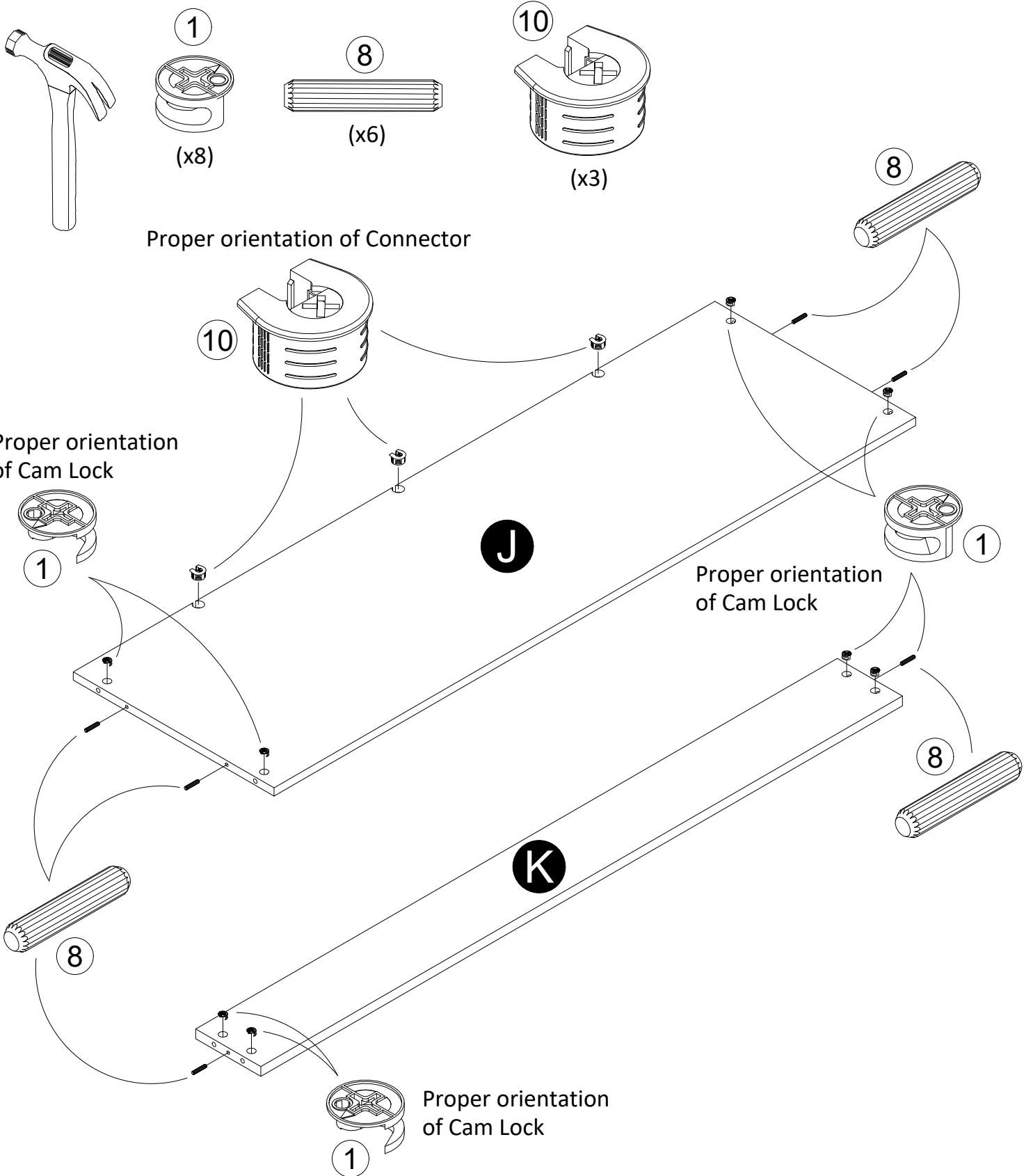

# STEP 4

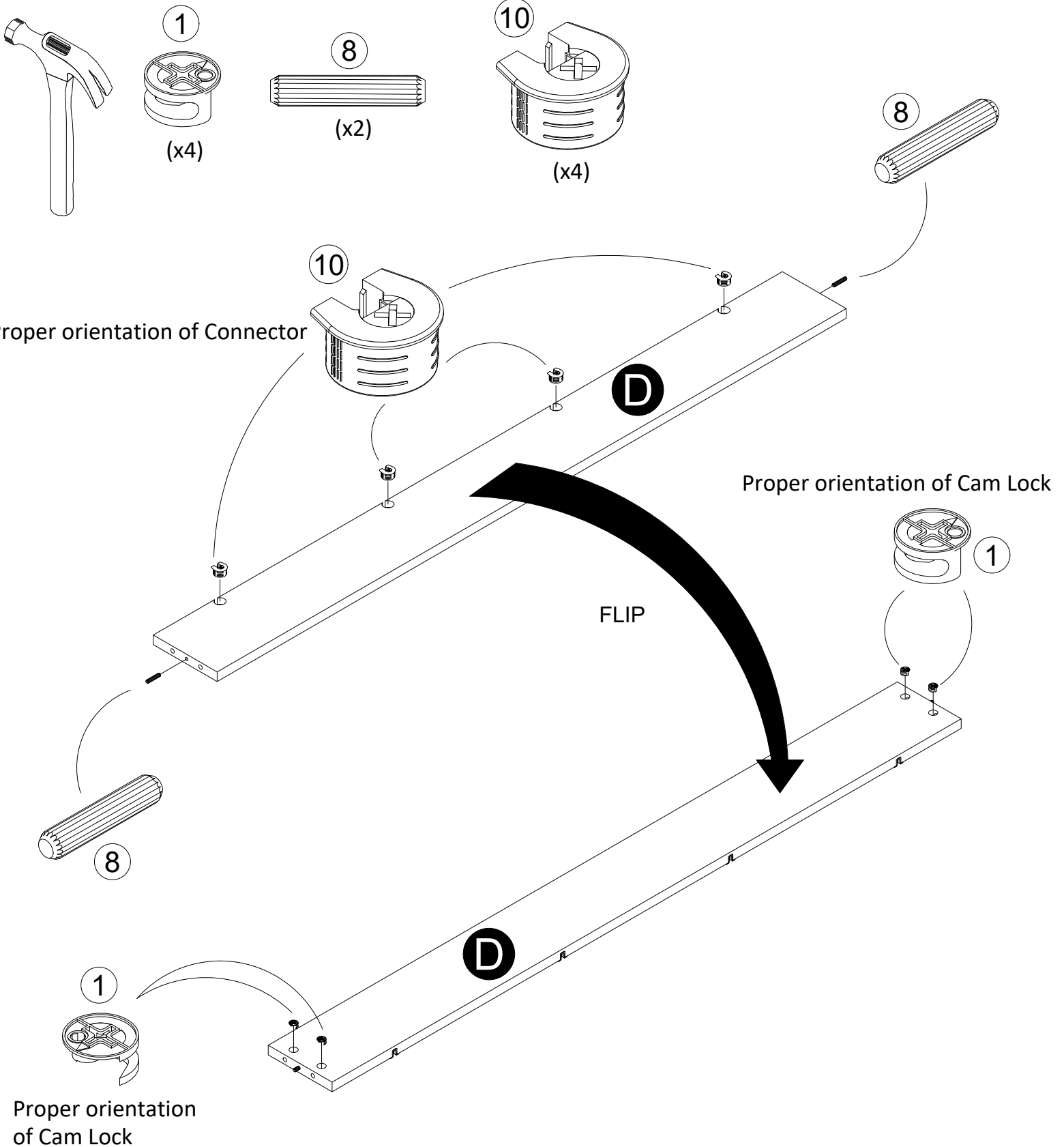

**STEP 5**

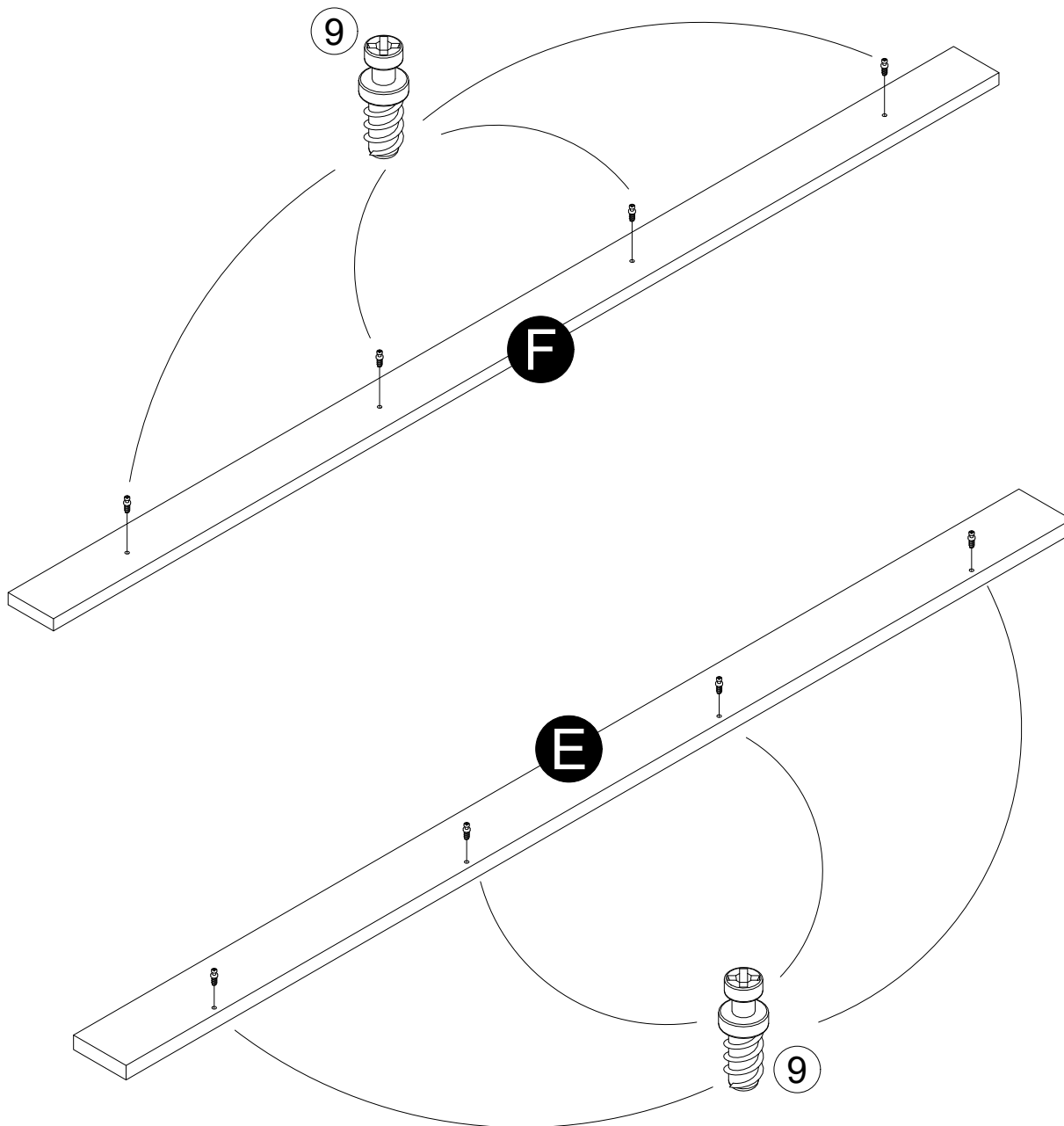
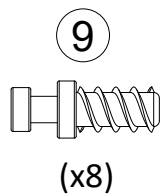
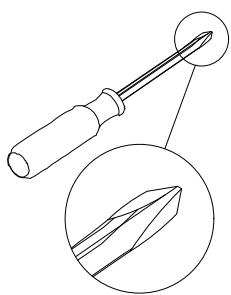

# STEP 6

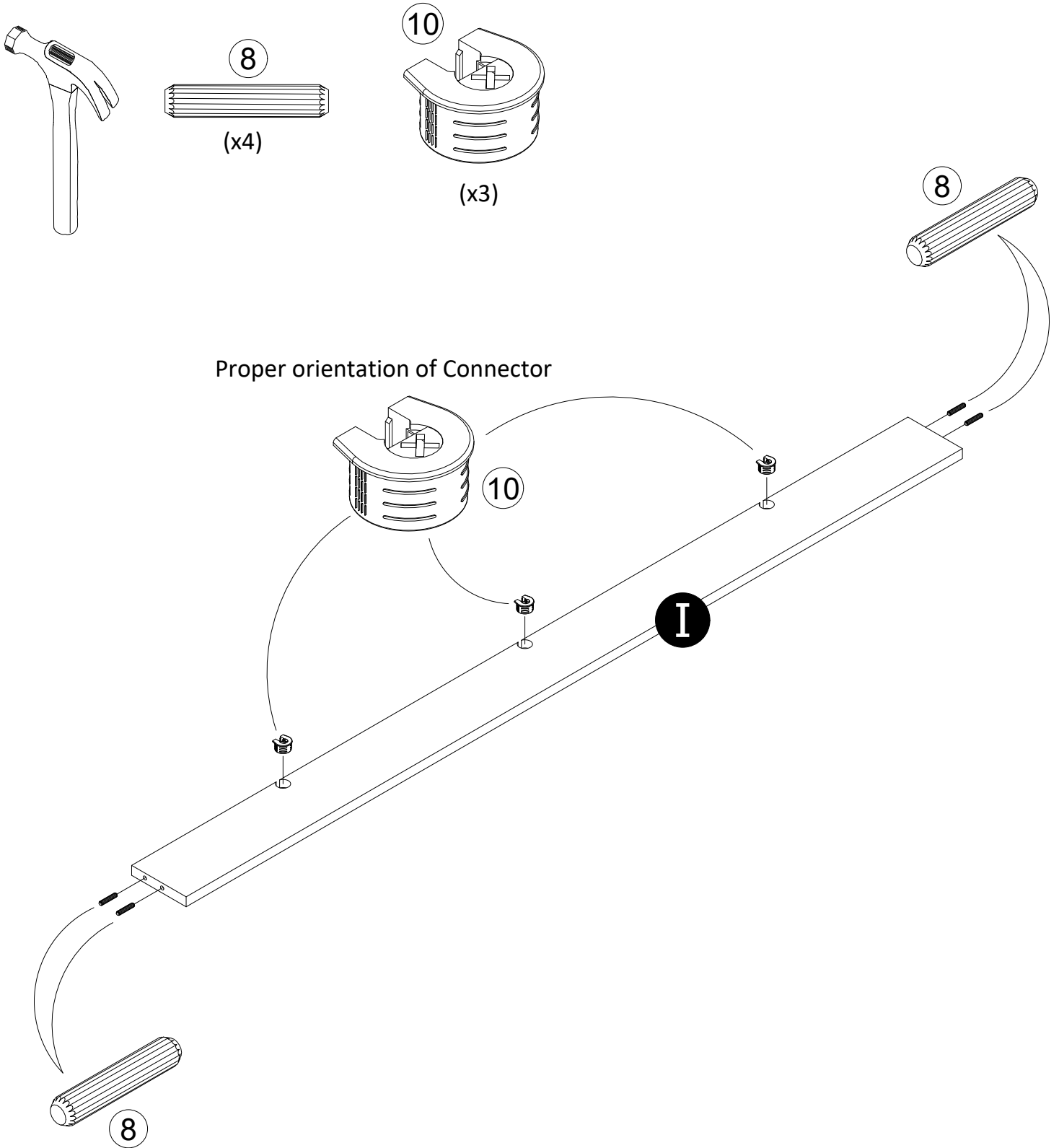

Proper orientation of Connector

**STEP 7**

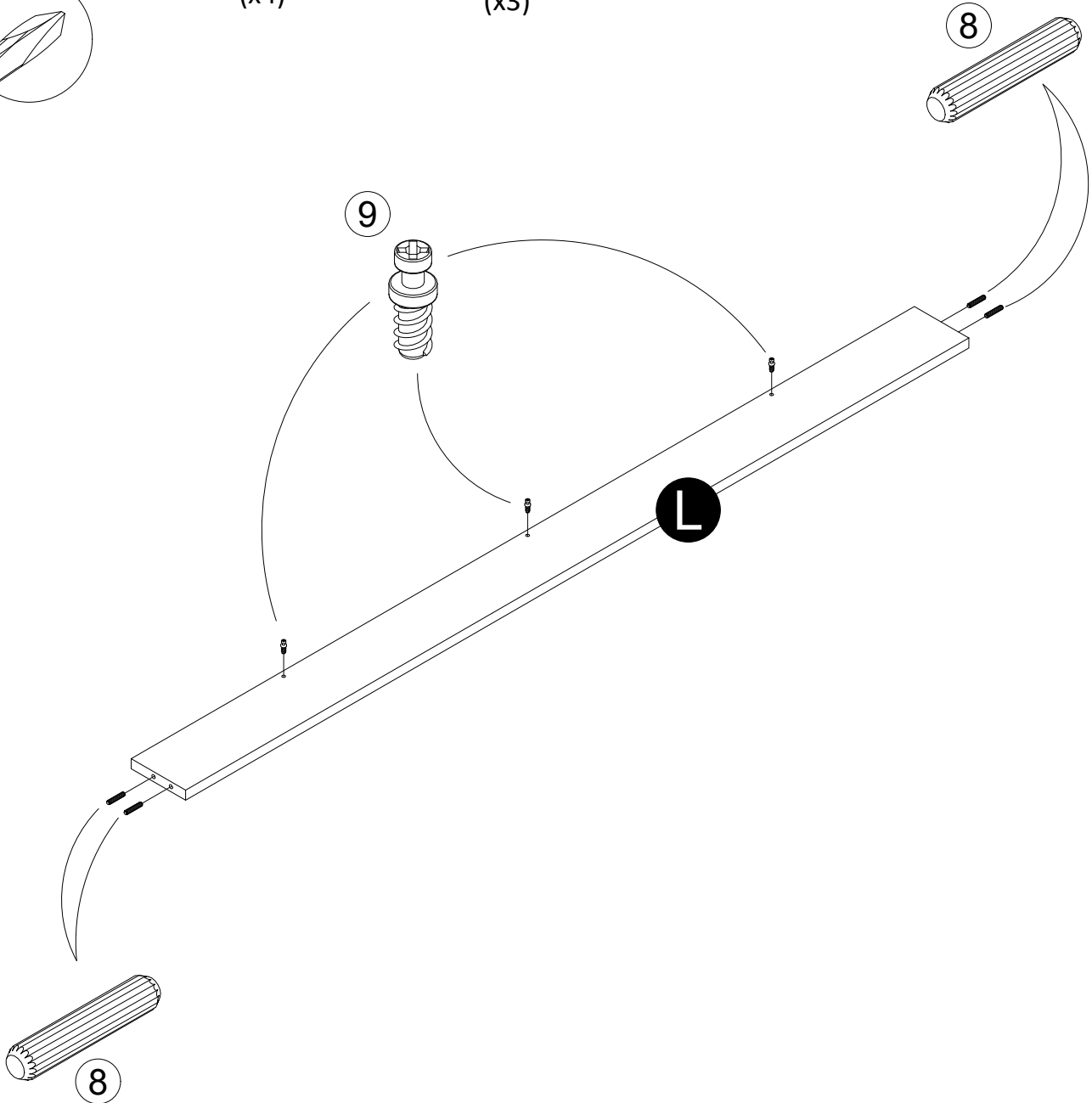
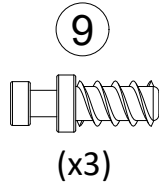
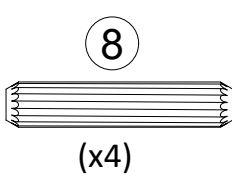
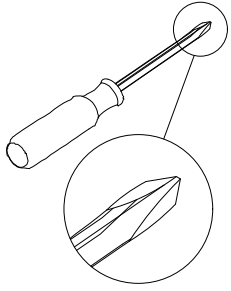

# STEP 8

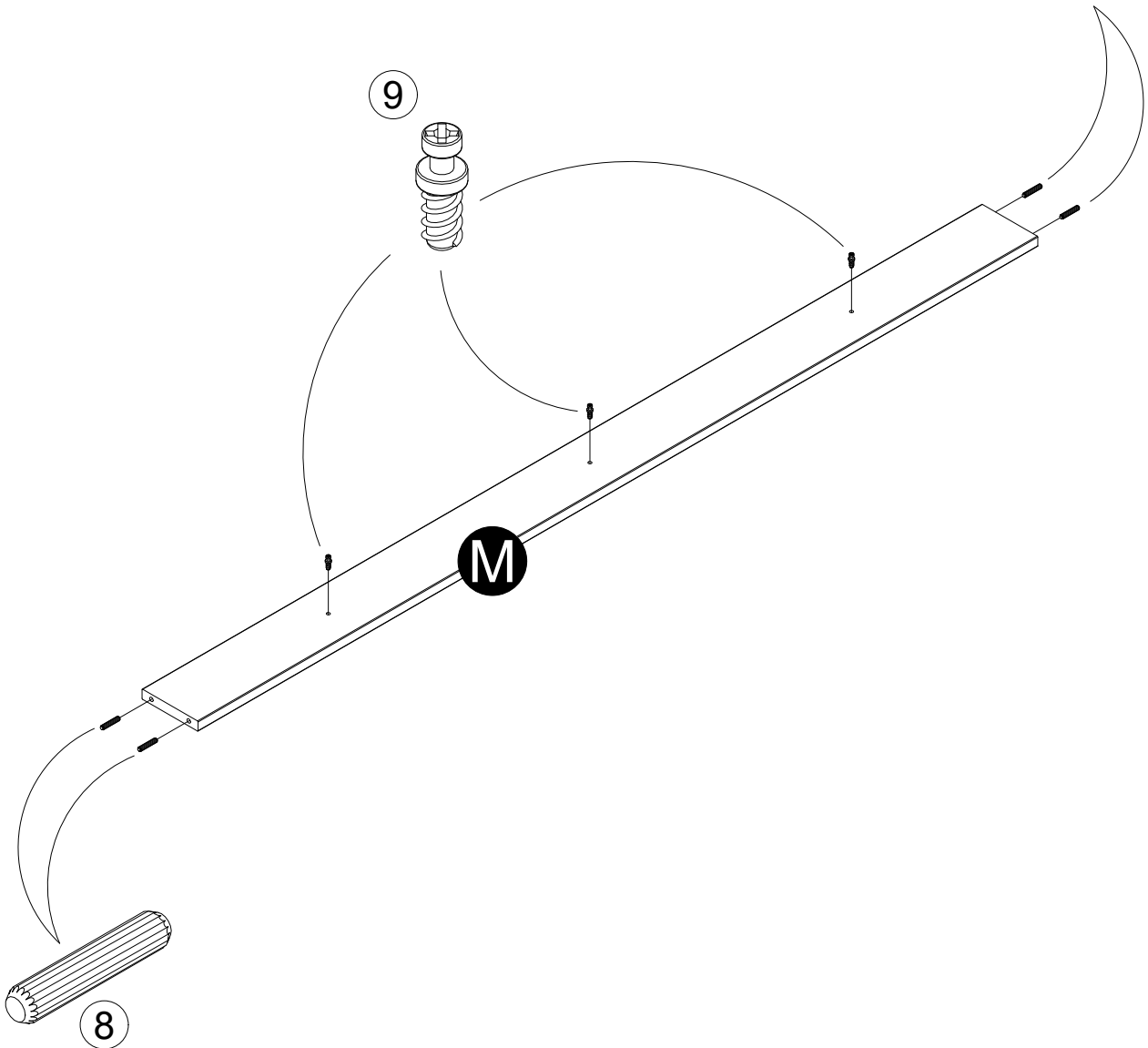
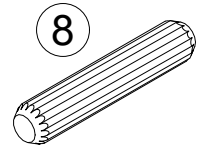
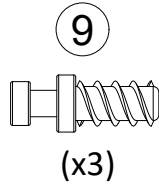
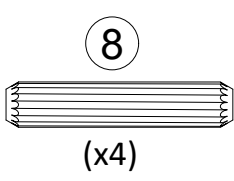
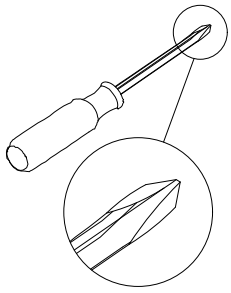



## STEP 9

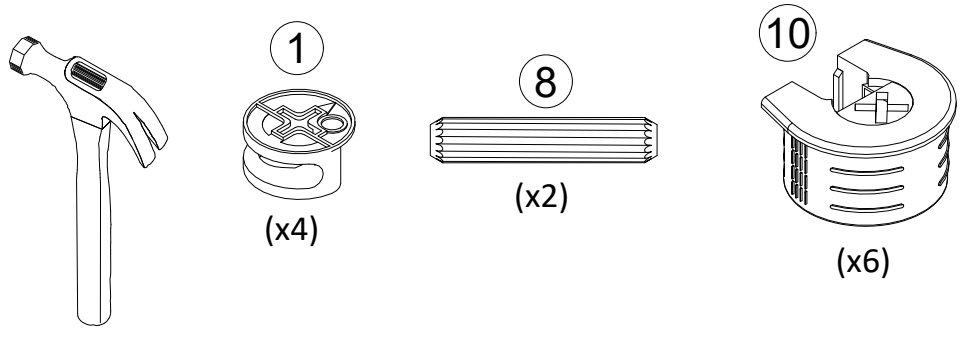

Proper orientation of Connector

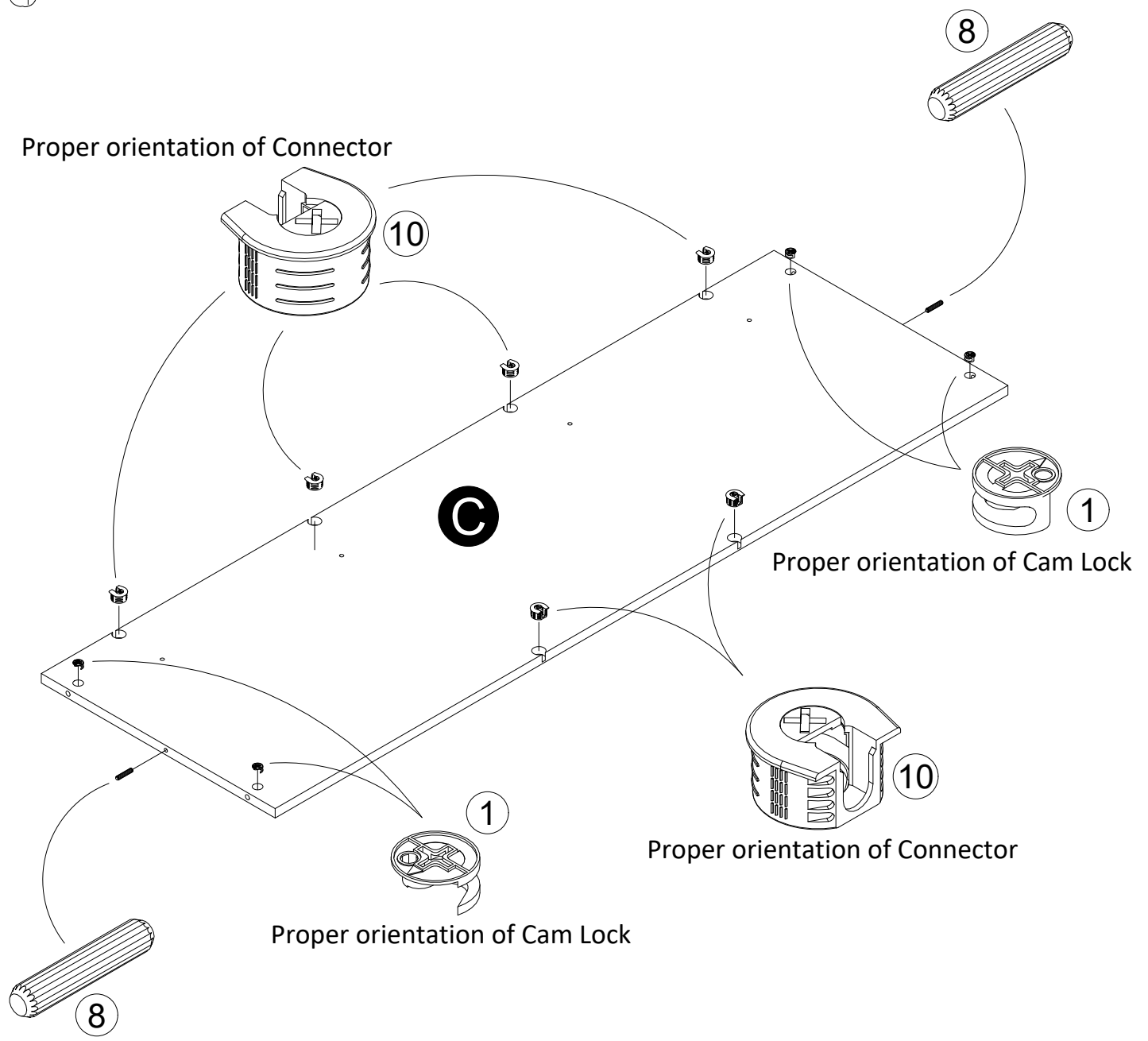

**STEP 10**

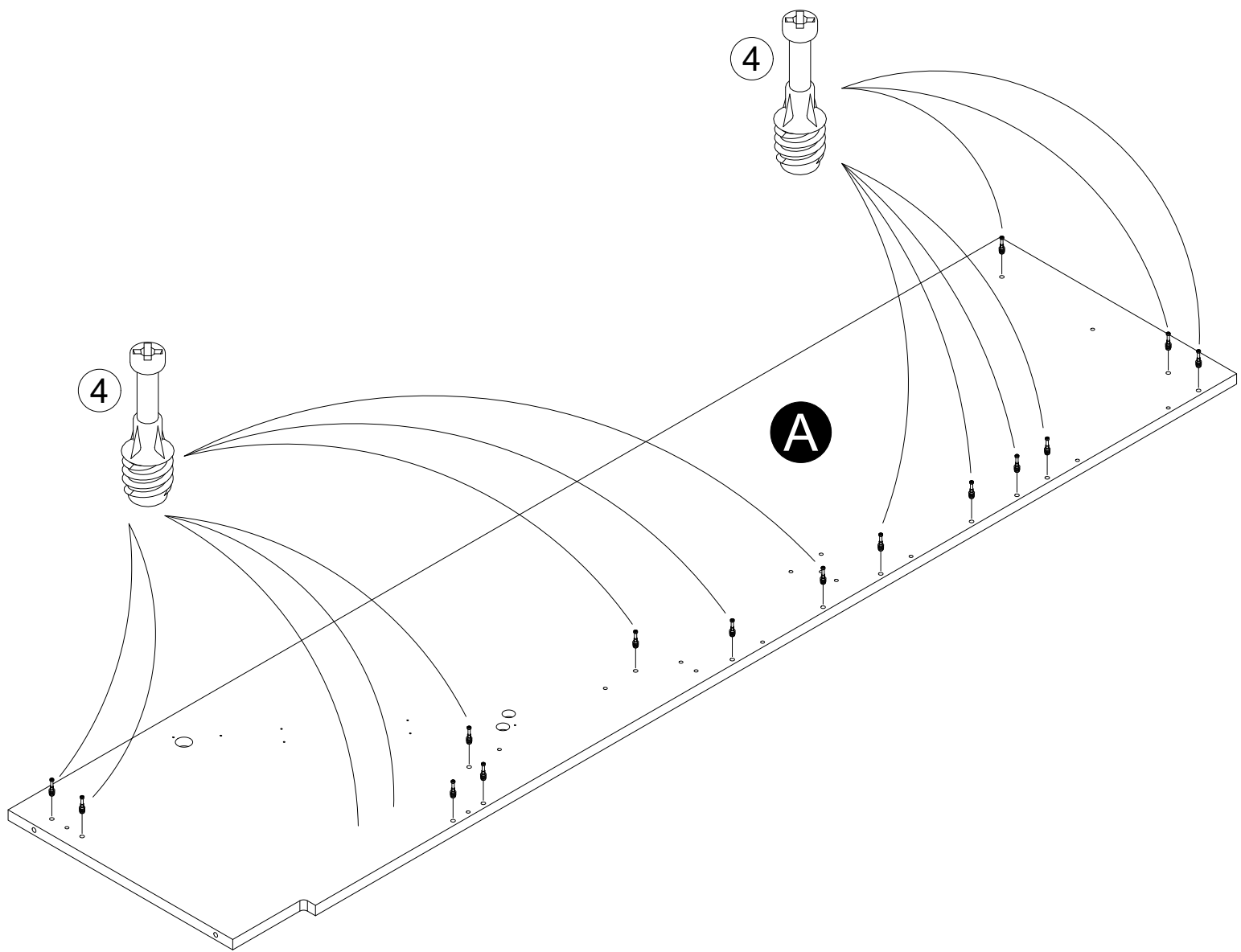
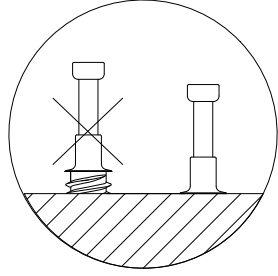
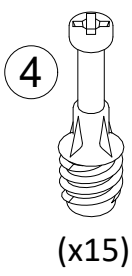
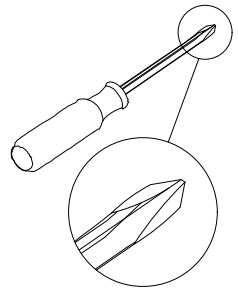

# STEP 11

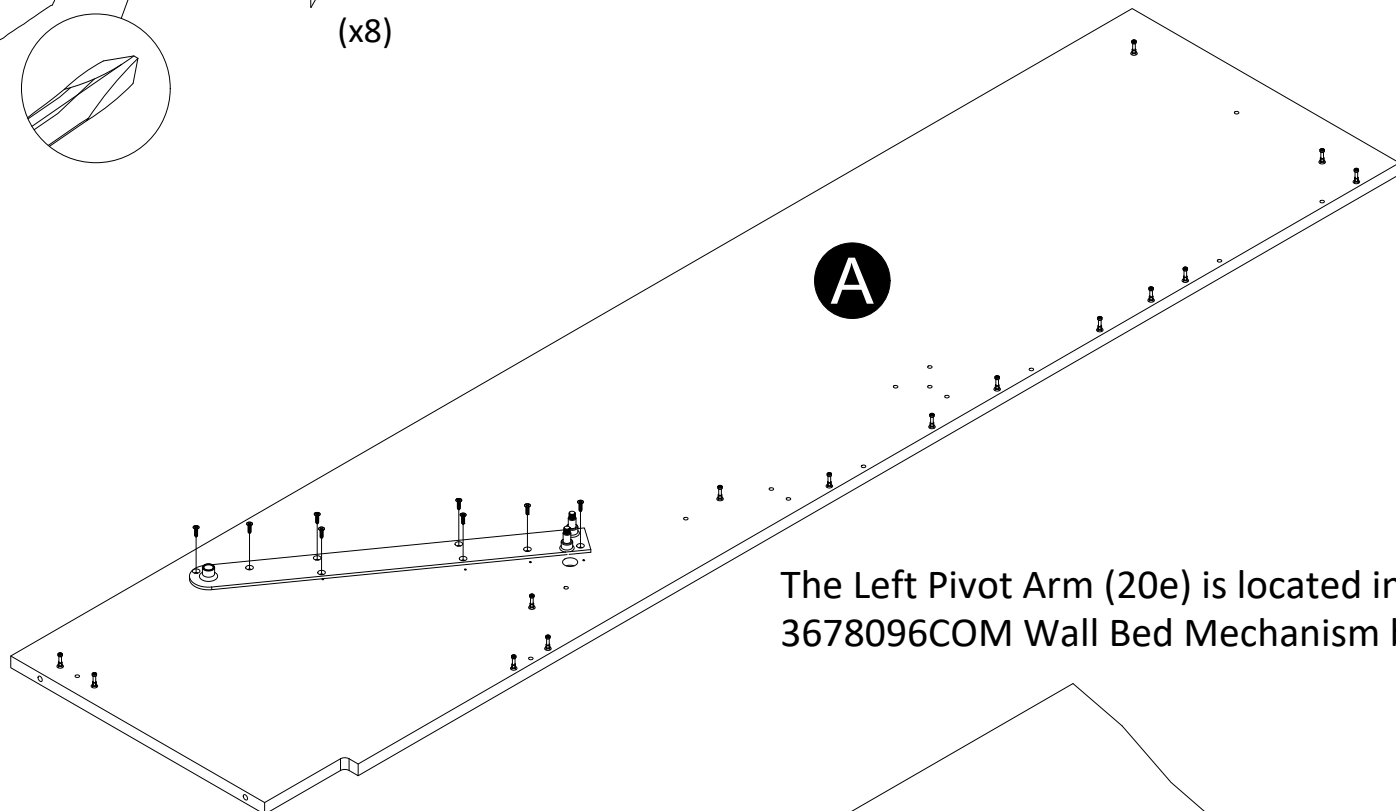
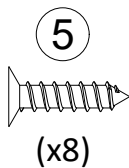
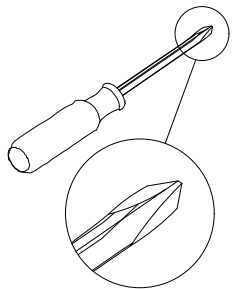

The Left Pivot Arm (20e) is located in the 3678096COM Wall Bed Mechanism box

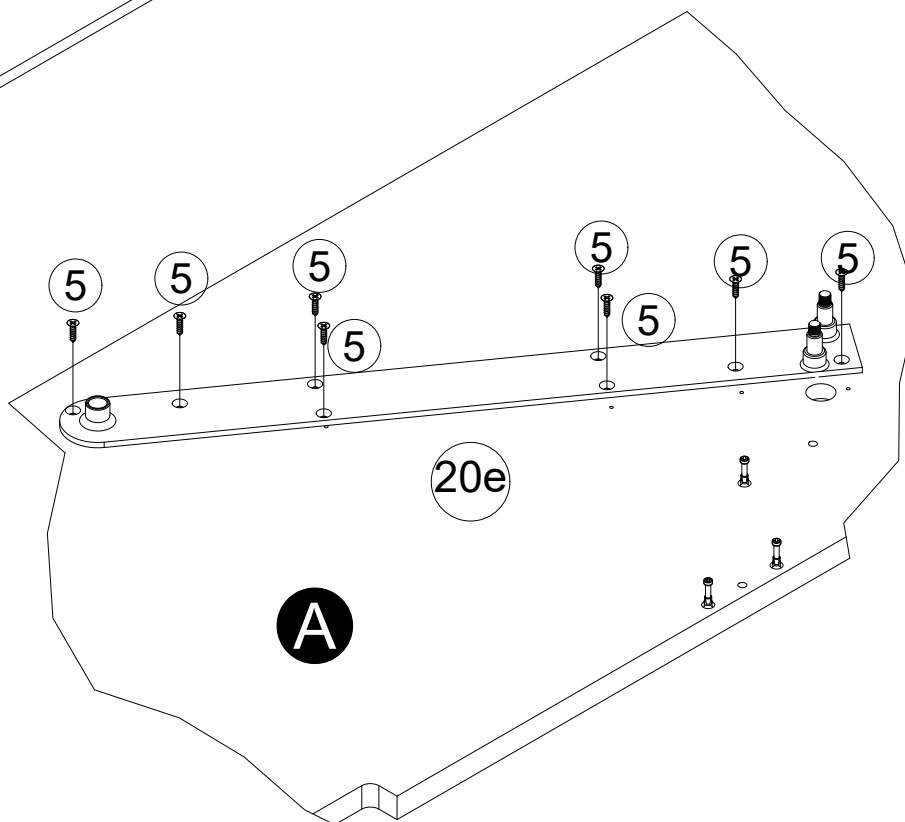

# STEP 12

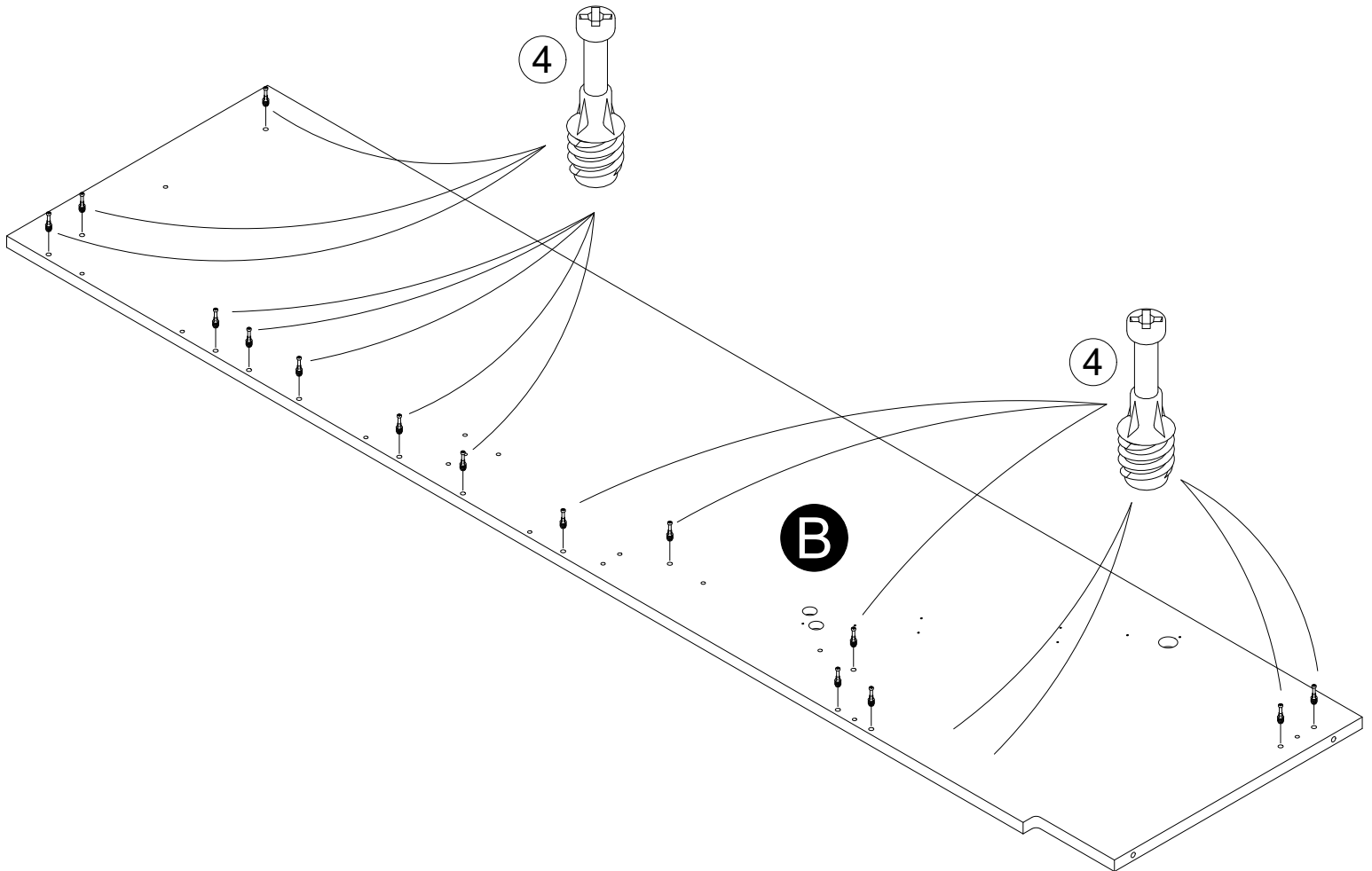
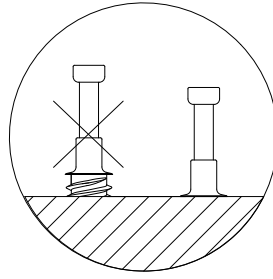
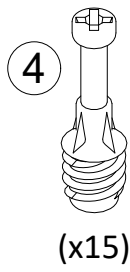
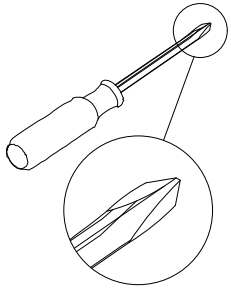

# STEP 13

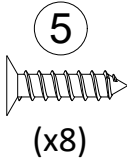
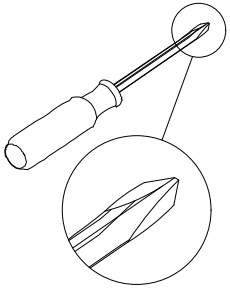

The Right Pivot Arm (20f) is located in the 3678096COM Wall Bed Mechanism box

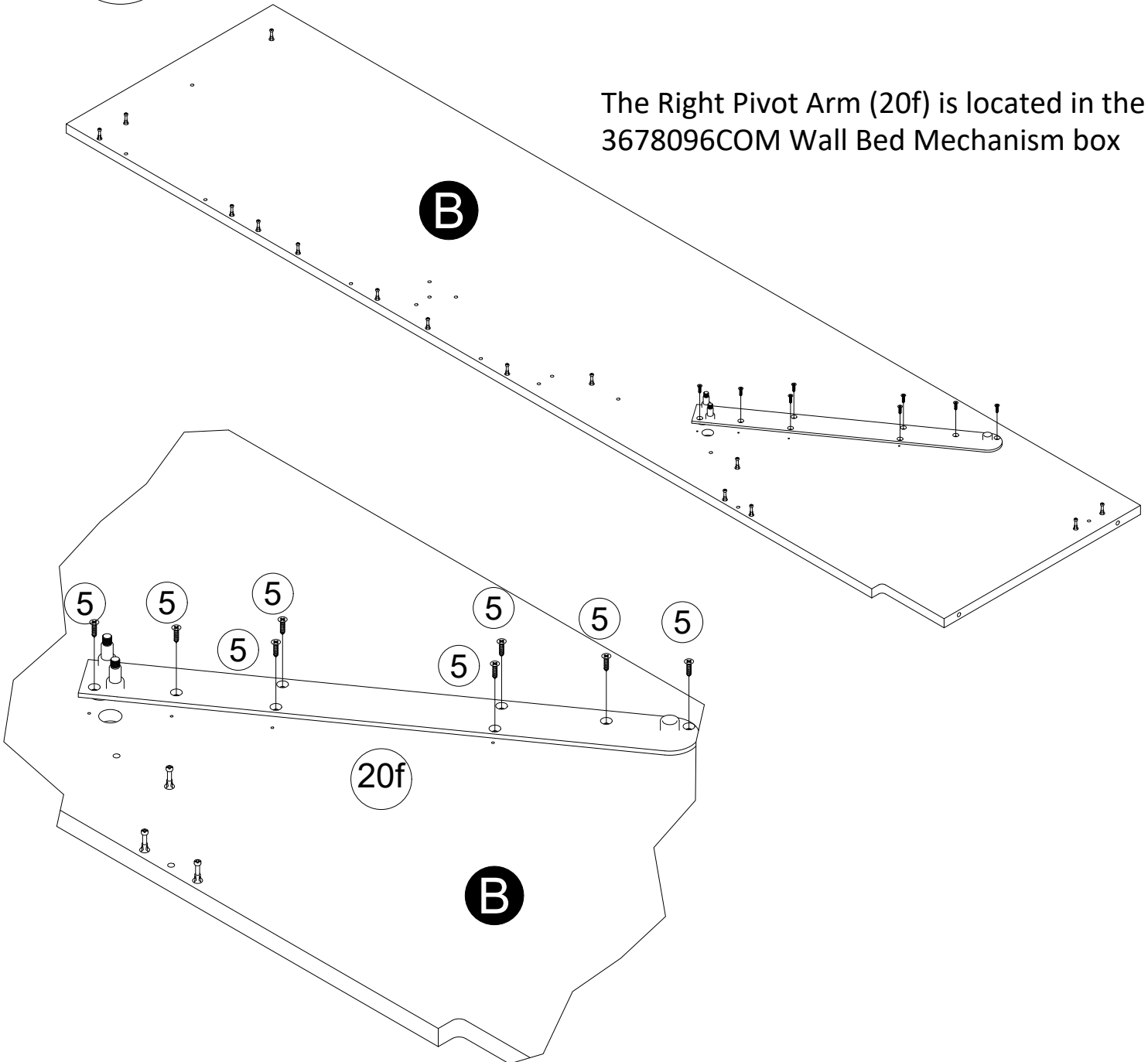

# STEP 14

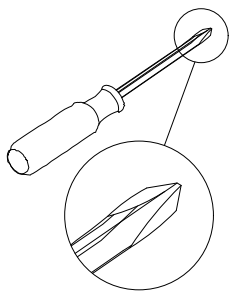

Turn clockwise  
to lock in place

**x4**

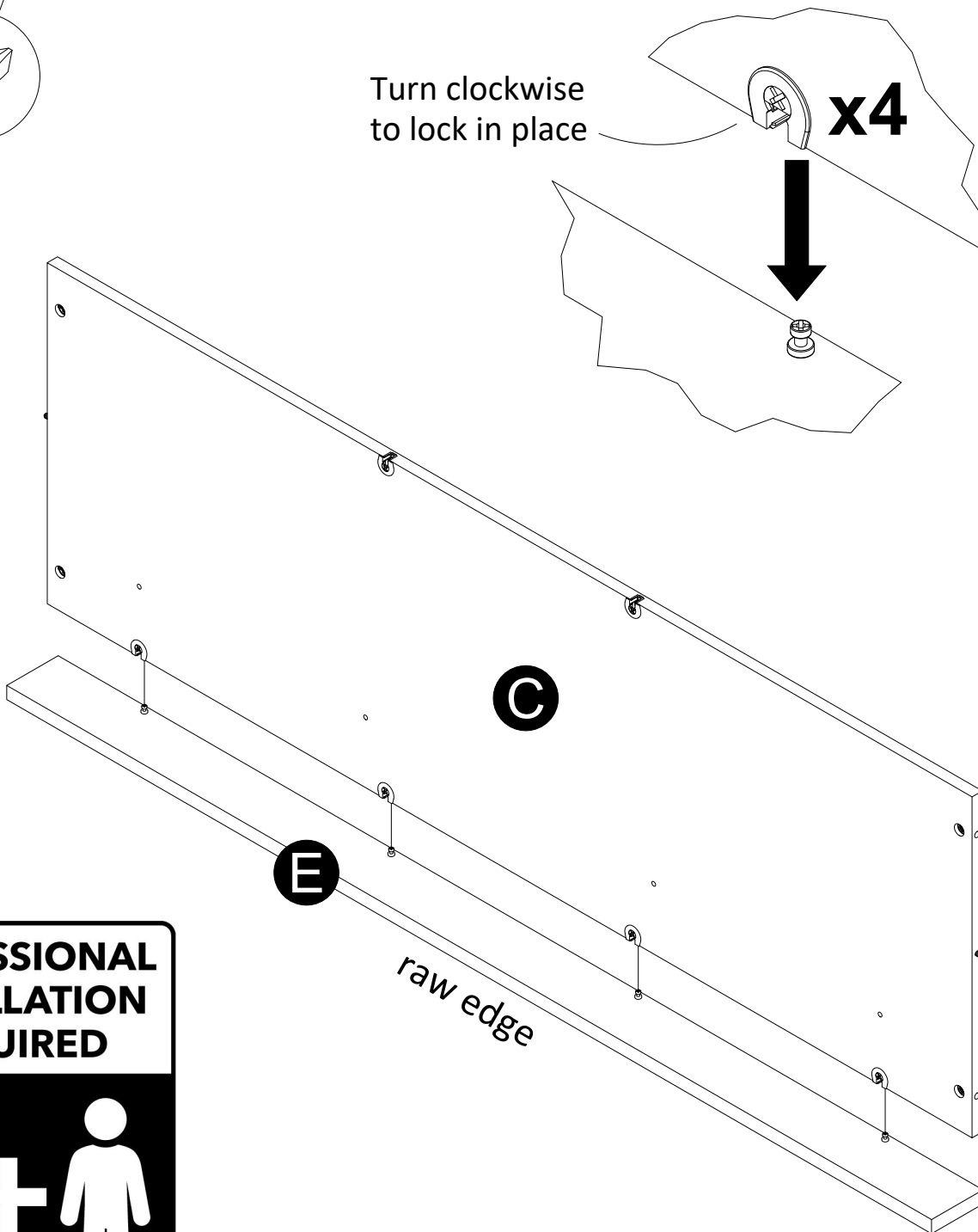

# STEP 15

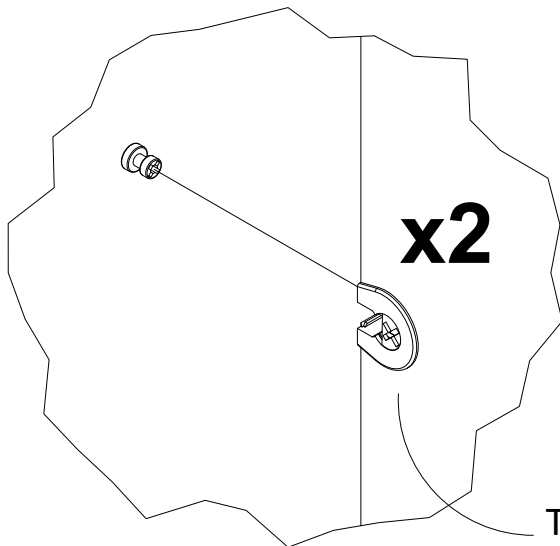
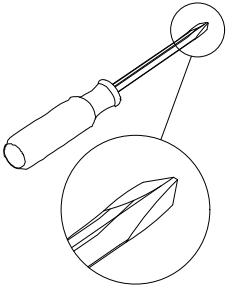

Turn clockwise to lock in place

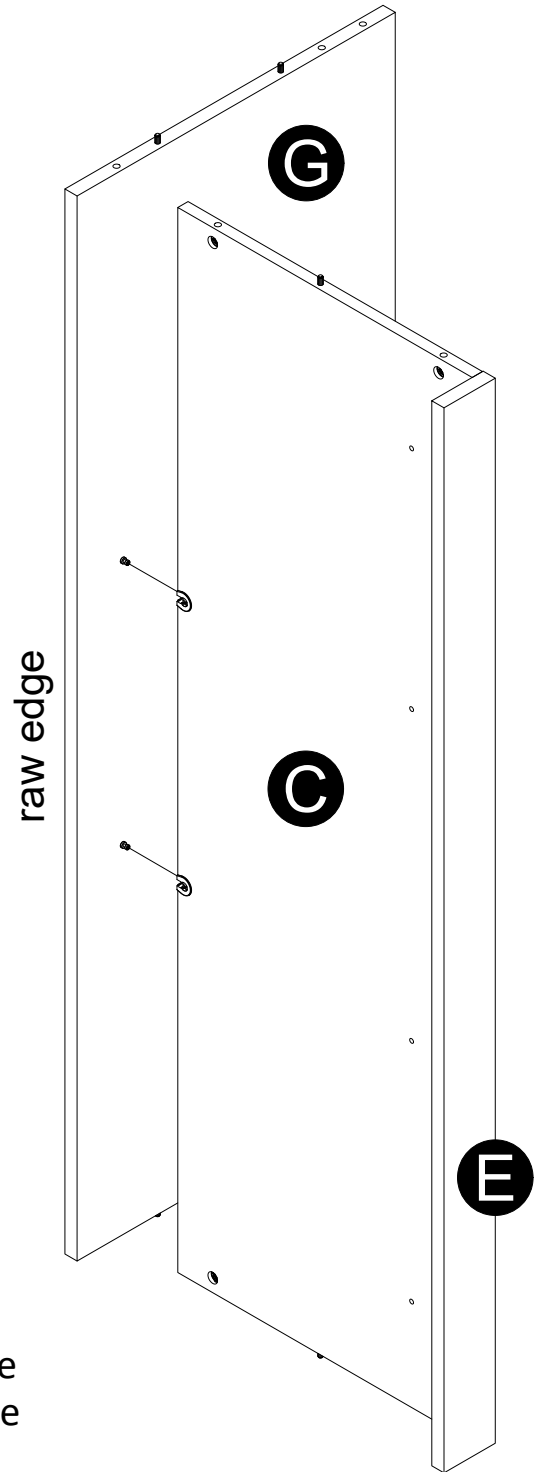

# STEP 16

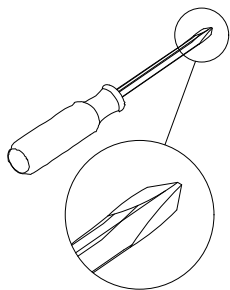

Turn clockwise  
to lock in place

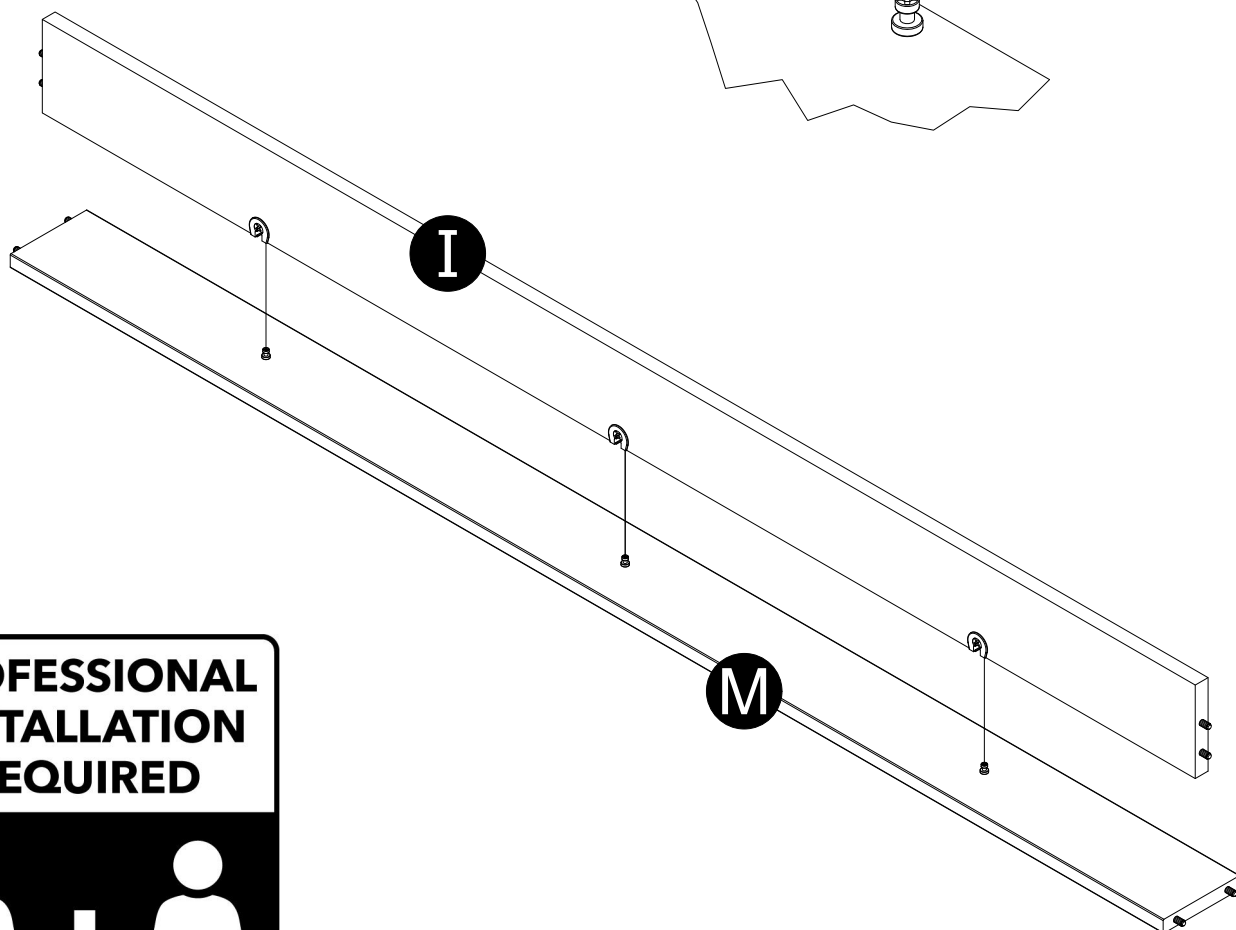
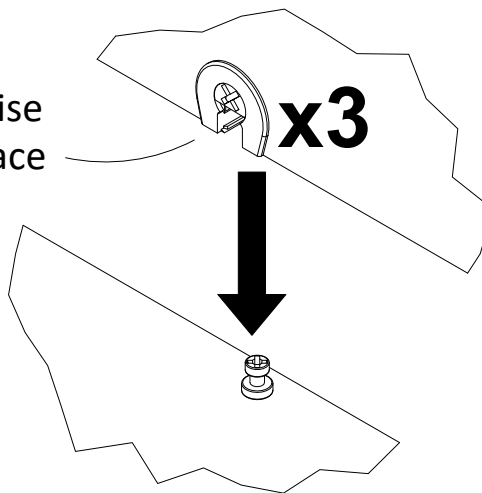



**STEP 17**

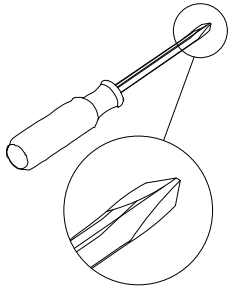

Turn clockwise  
to lock in place

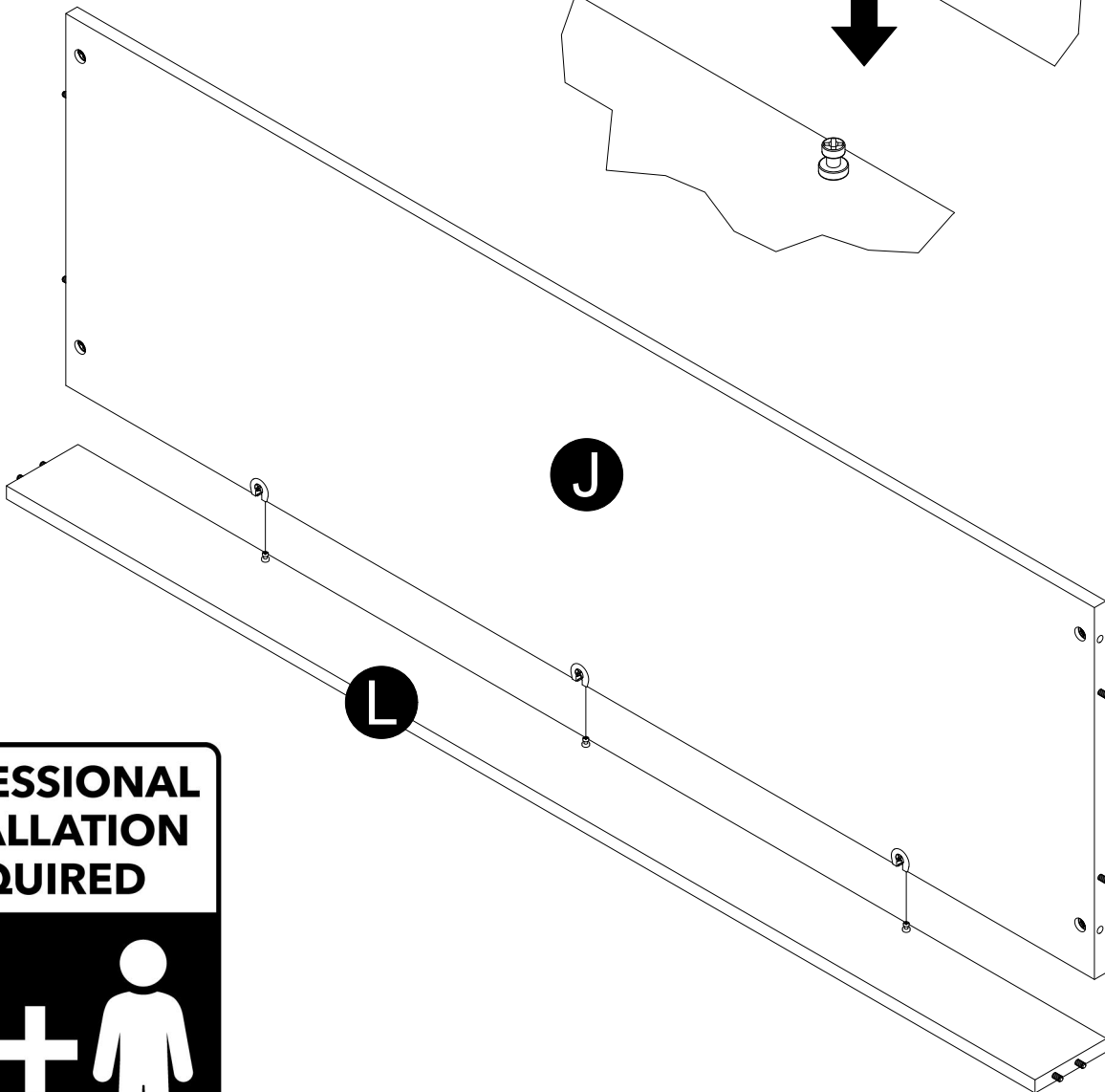
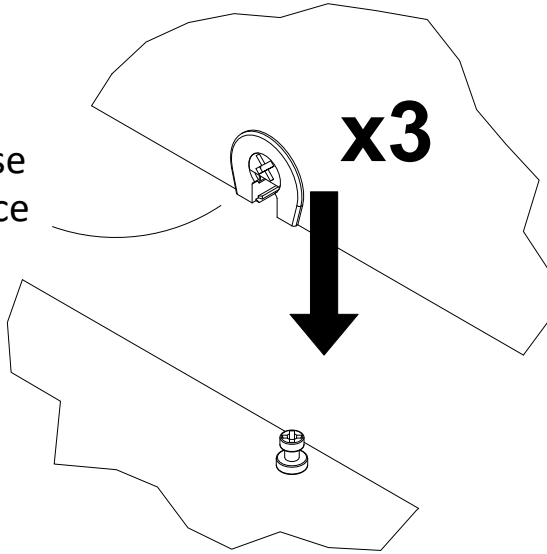

**STEP 18**

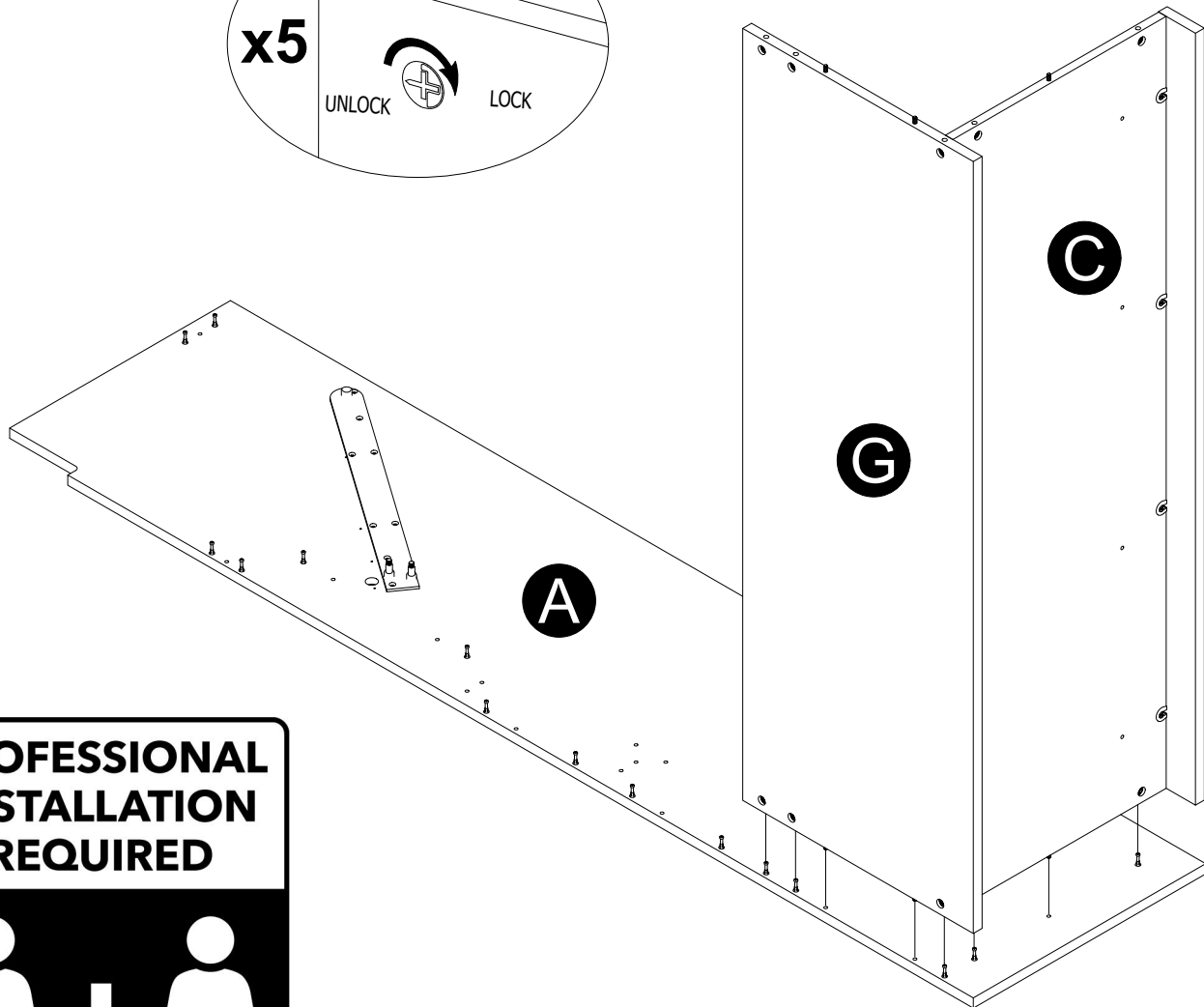
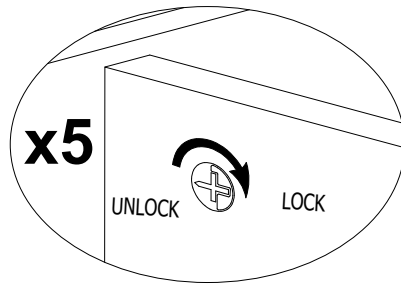
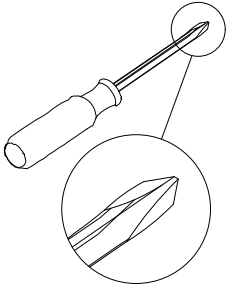

# STEP 19

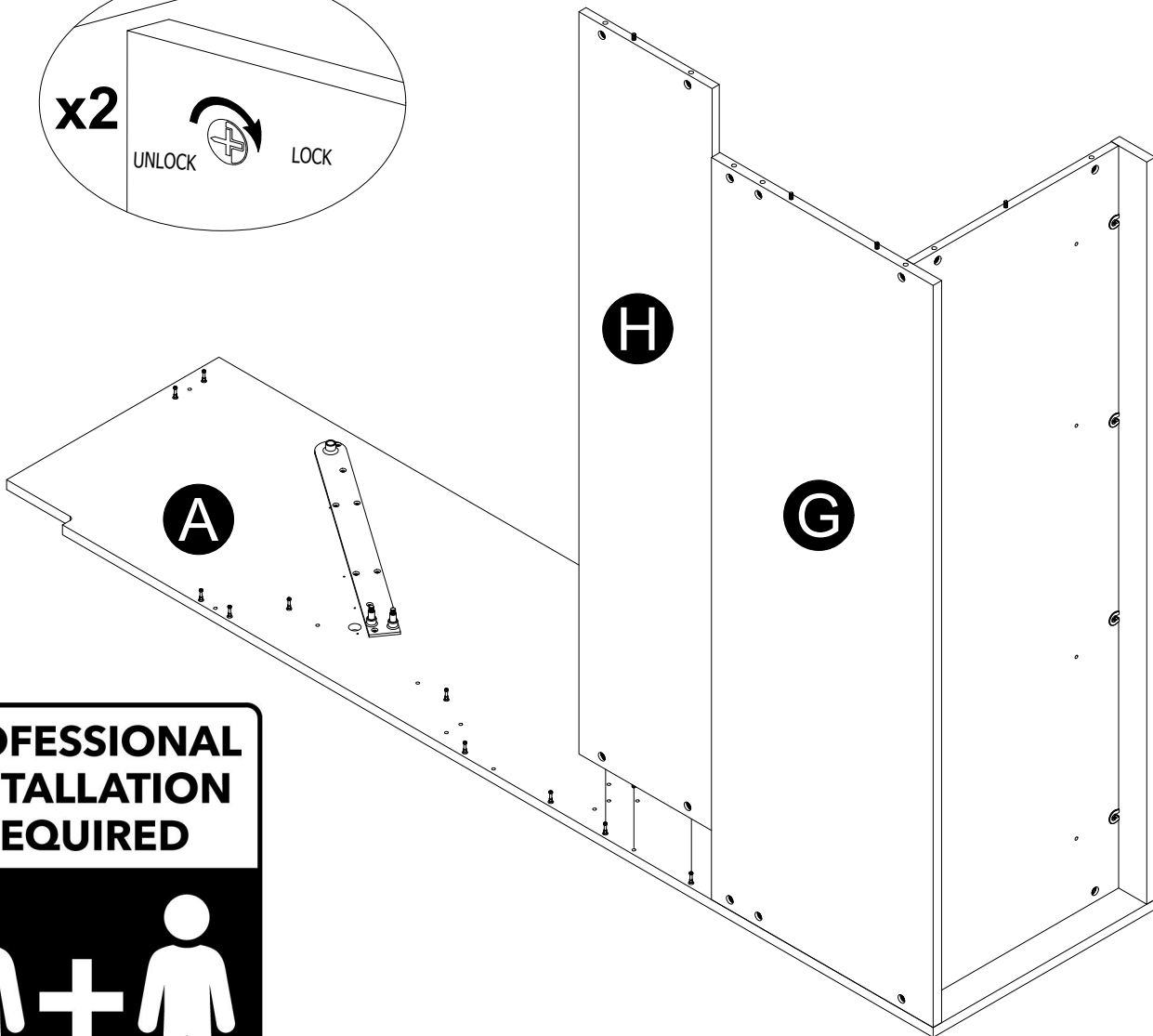
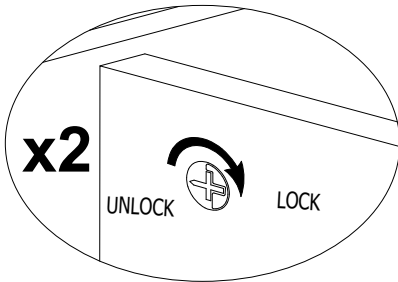
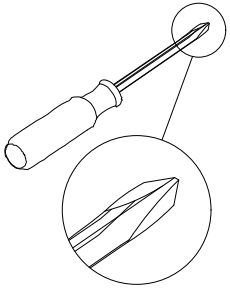

**STEP 20**

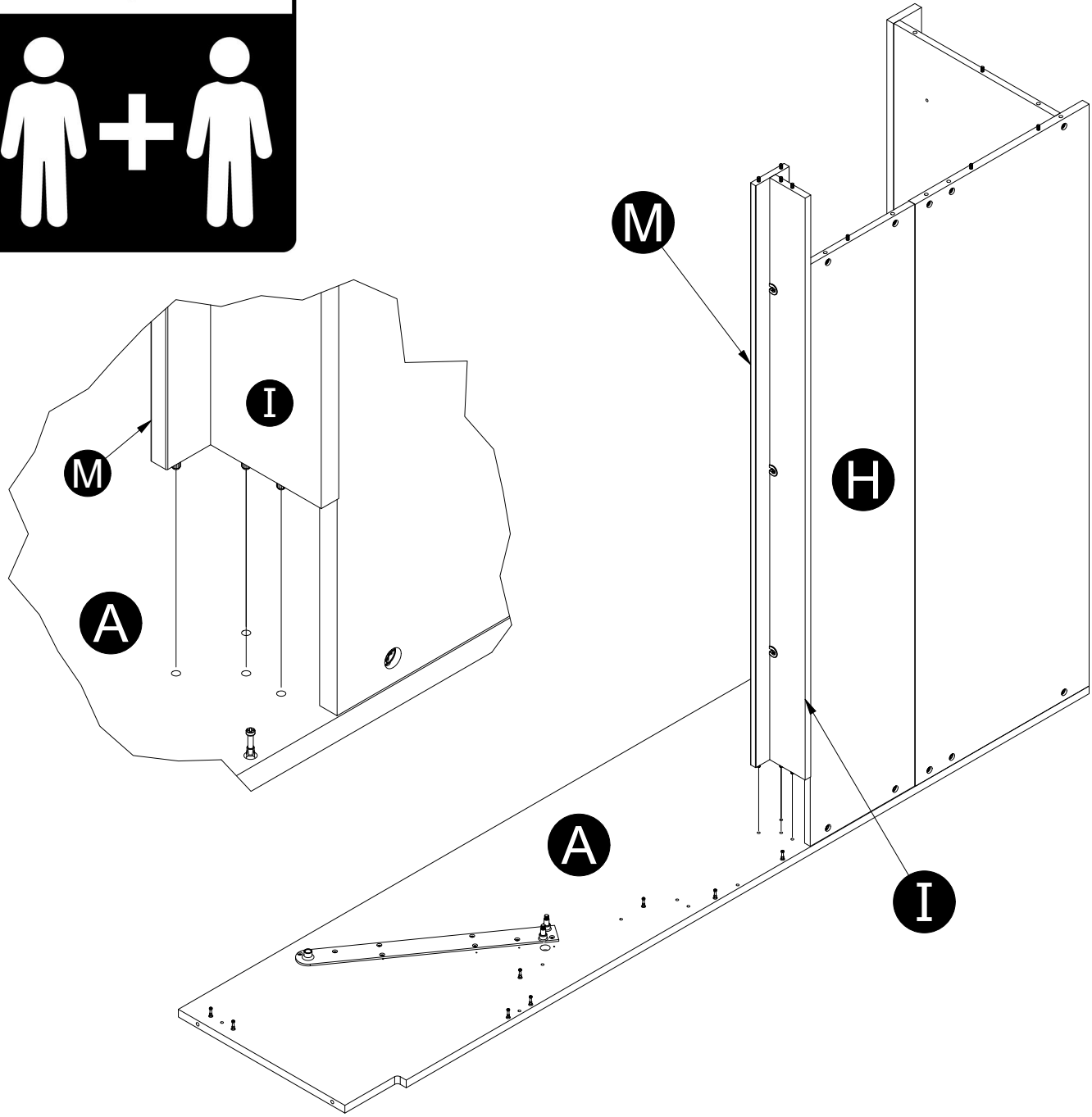

# STEP 21

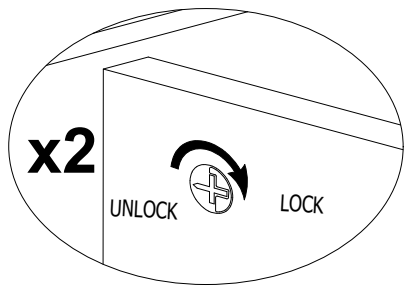
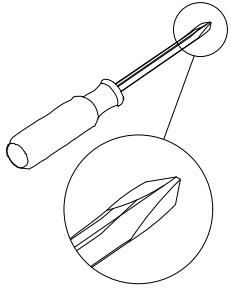

Dowel is closer to the edge here

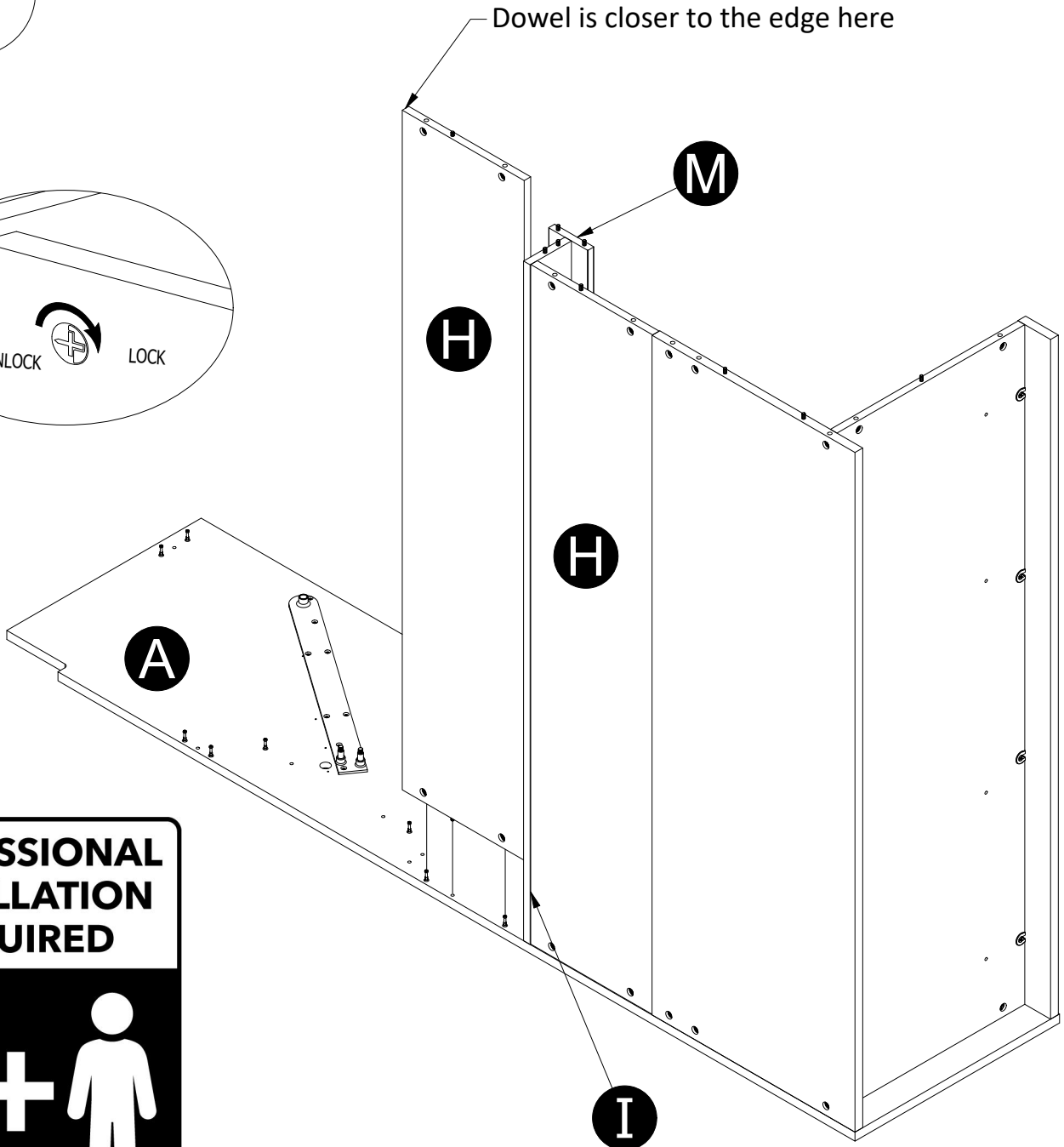

# STEP 22

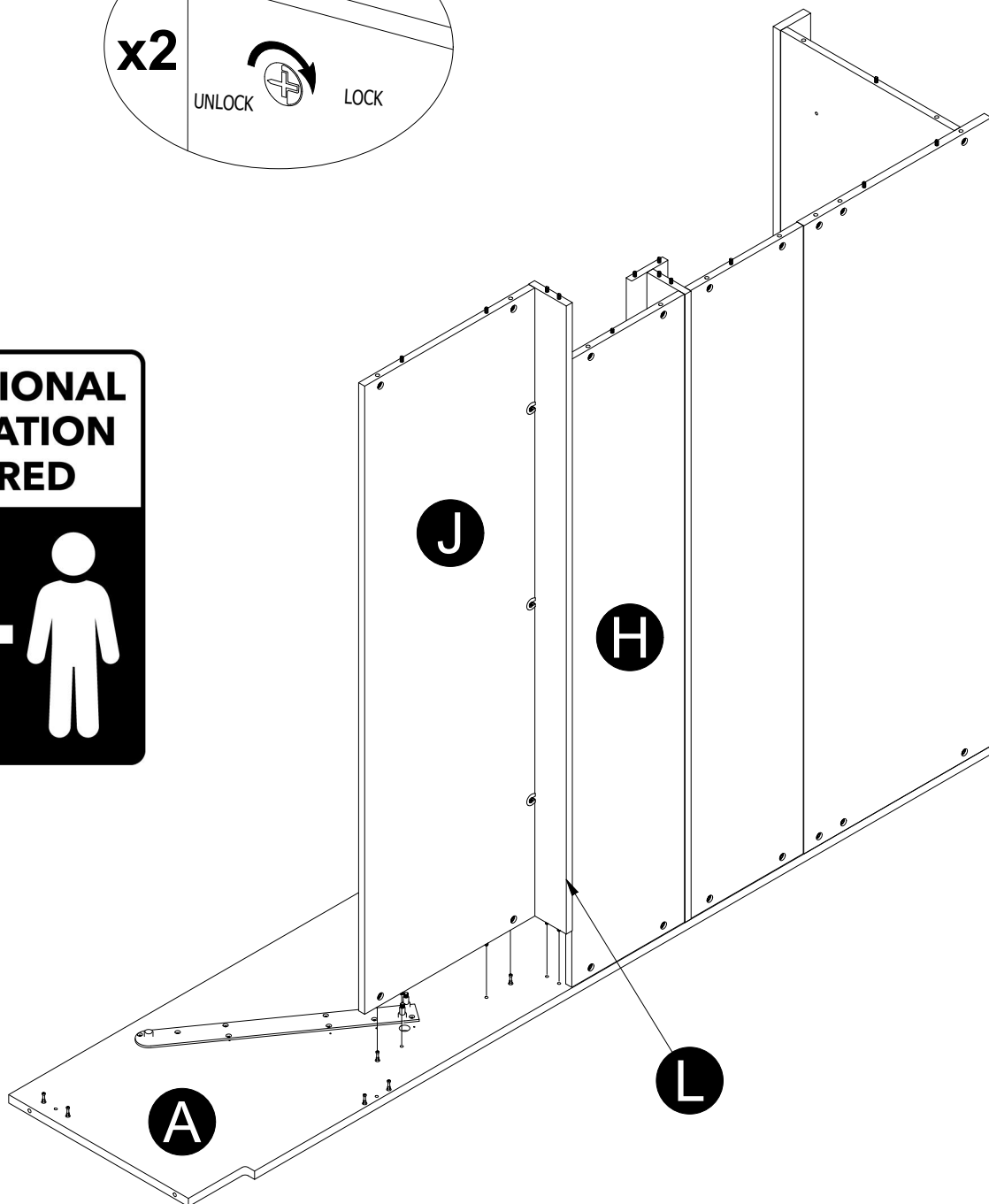
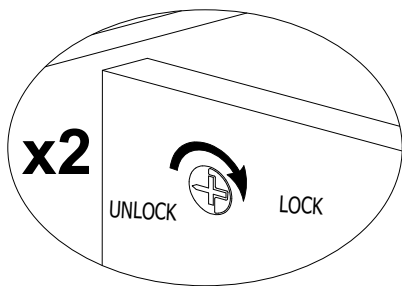
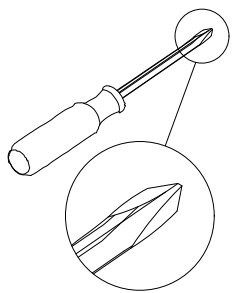

# STEP 23

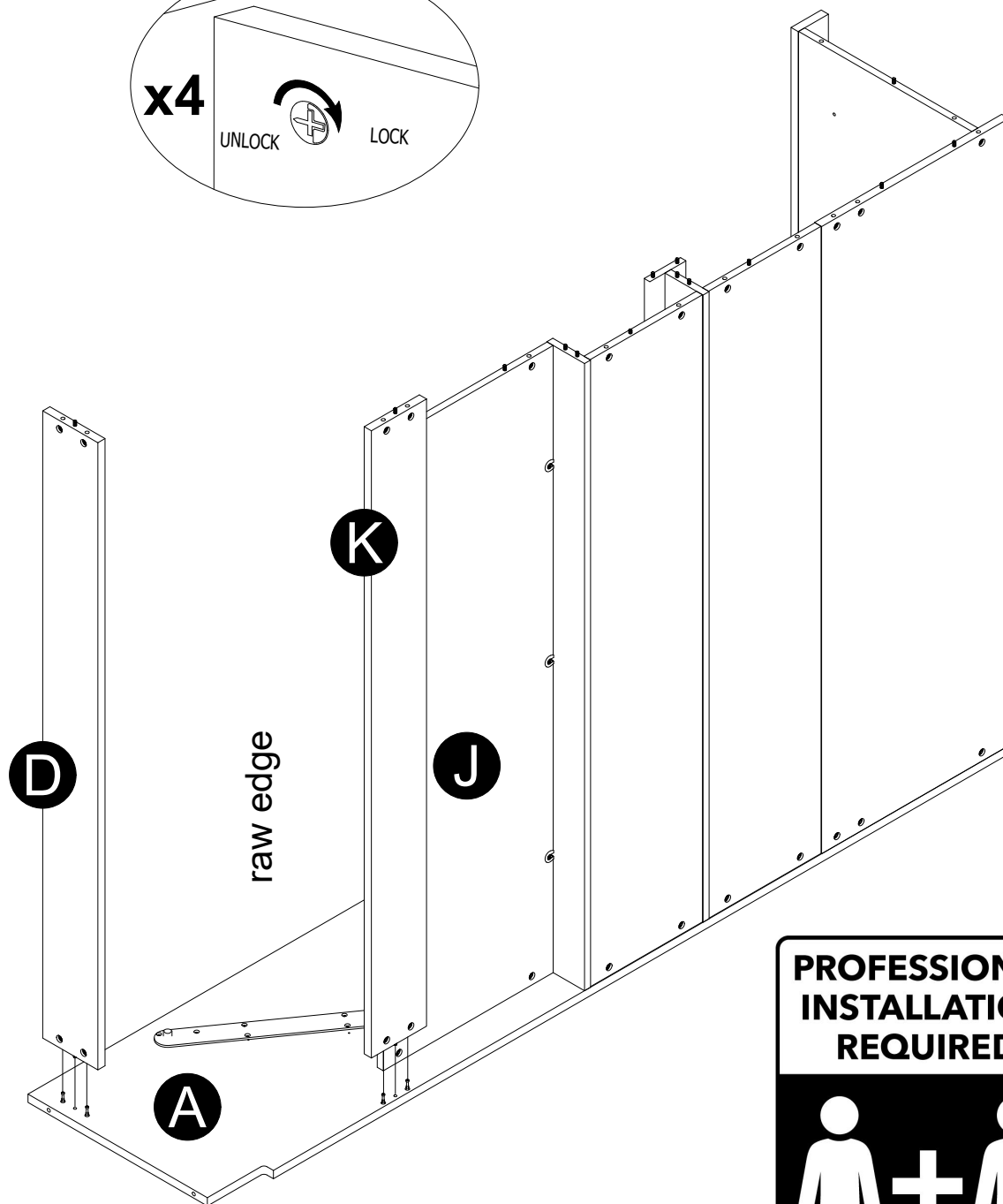
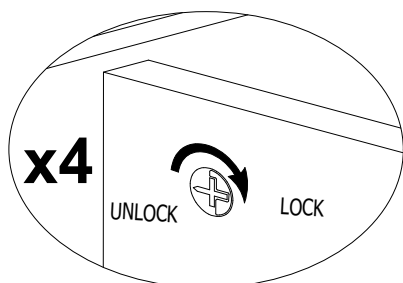
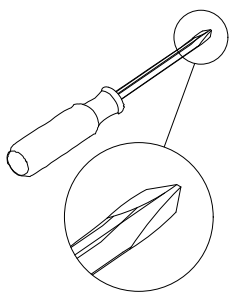

**PROFESSIONAL  
INSTALLATION  
REQUIRED**

An icon consisting of two stylized human figures standing on either side of a plus sign, indicating that two people are required for installation.

# STEP 24

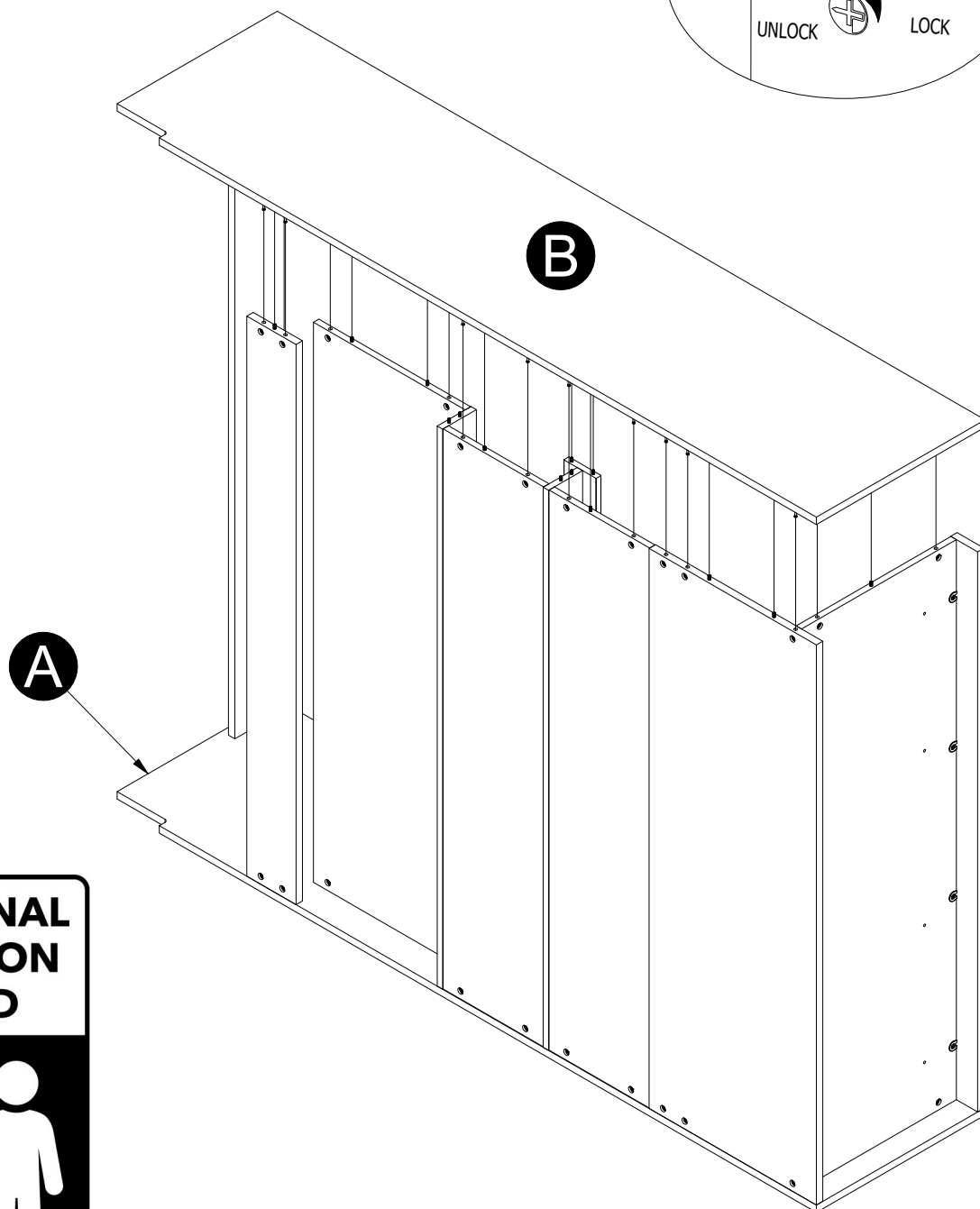
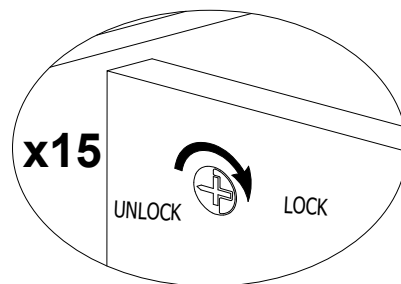
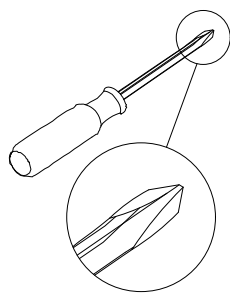

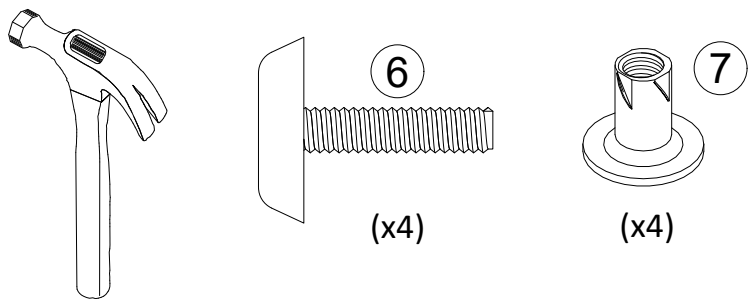

**STEP 25**

Lay the unit onto it's front.

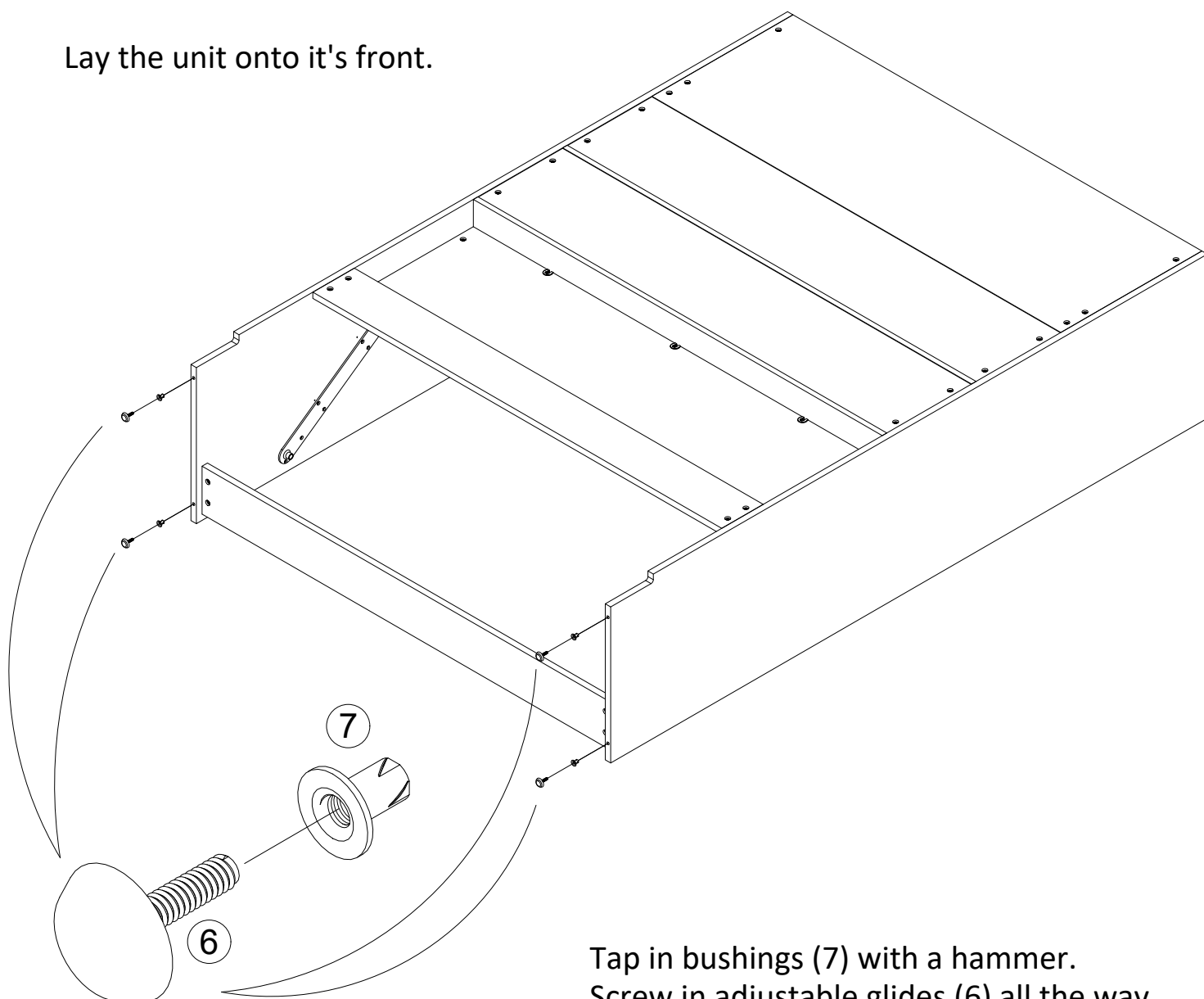

Tap in bushings (7) with a hammer.  
Screw in adjustable glides (6) all the way.

**The next steps are to assemble your unit to the wall**



**Assembled unit MUST be square on the height, width, and depth to function properly**

**Assembled unit MUST be placed flat against the wall**

**Assembled unit MUST be screwed into 3 DIFFERENT wall studs at the top and bottom for safety**

**Screws provided are for drywall and wood studs. If walls are masonry, concrete, or other wall materials: Use appropriate hardware to securely attach your unit to the wall**

**DO NOT use wall anchors to fasten your unit to the wall**

**Relocation isn't suggested after assembly!**

## STEP 26

Place your unit **FLUSH** against the wall



There are notches provided at the back of your unit. These notches are to fit around the baseboard on your wall. If your baseboard is higher or thicker than the notches provided on the unit, you will need to remove the baseboard, cut it down to fit on both sides of your unit, then refasten to the wall.

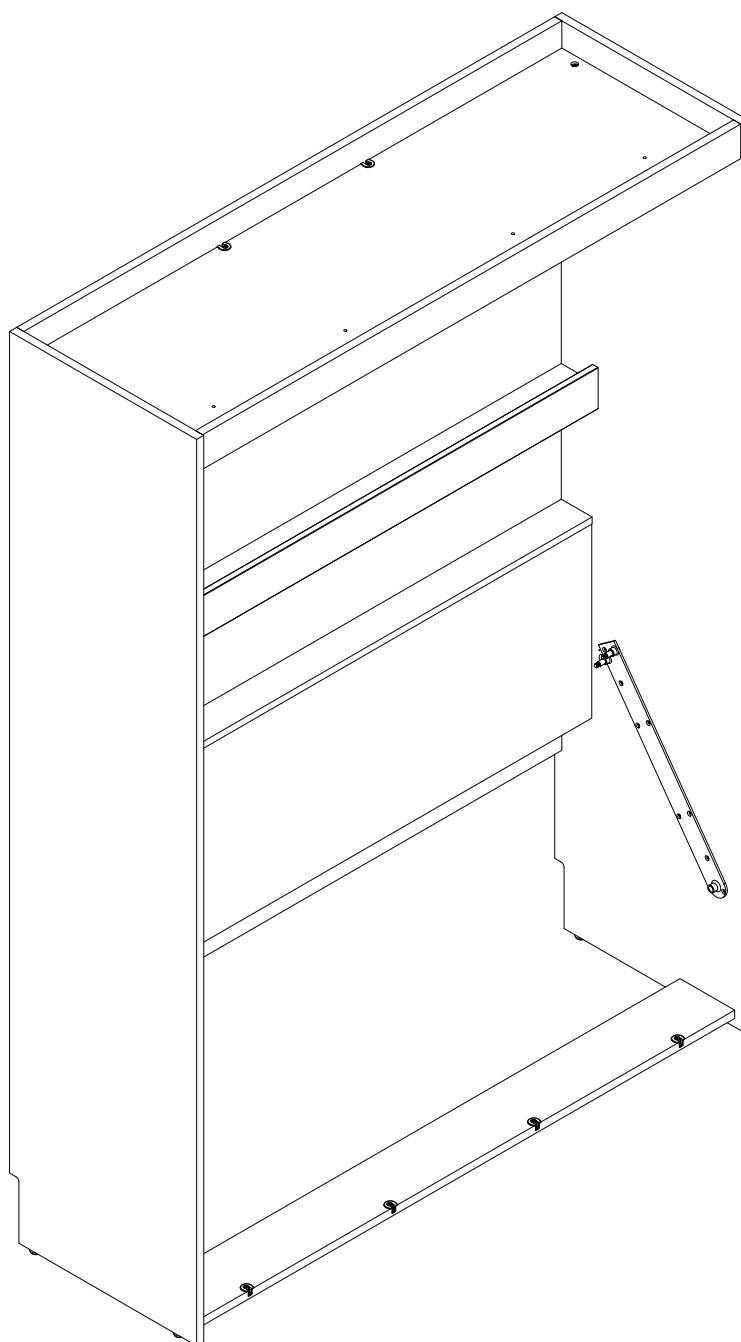

# STEP 27

Assembled unit **MUST** be flush on the height, width, and depth to function properly



**A ladder will be required  
Do not lean against the  
top of the unit, it may  
cause sagging**

If required, unscrew the  
Glides counter-clockwise  
as necessary in all 4  
corners until your unit is  
level in all directions

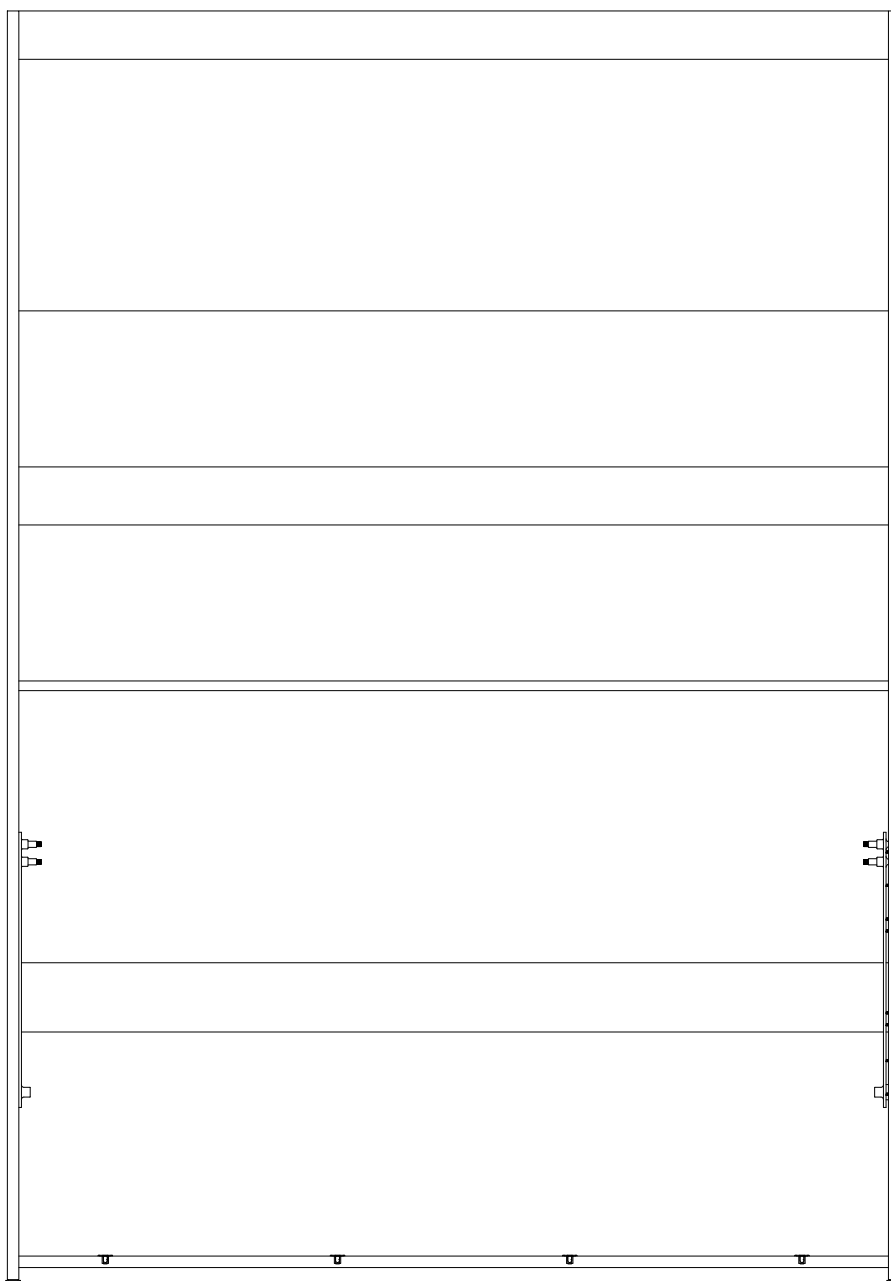
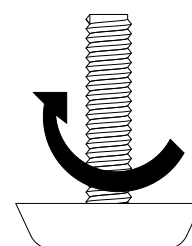

# STEP 28



Locate the studs in the wall, using a stud finder.  
Using a pencil, mark the stud locations on the upper surface of the Upper Back Panel (G).  
Using a level, carry the stud locations down to the Bottom Stringer (K), and with a pencil, mark the stud locations.

**You need to locate at least 3 DIFFERENT studs, in the horizontal direction, but 4 is better.**

## Wall Studs

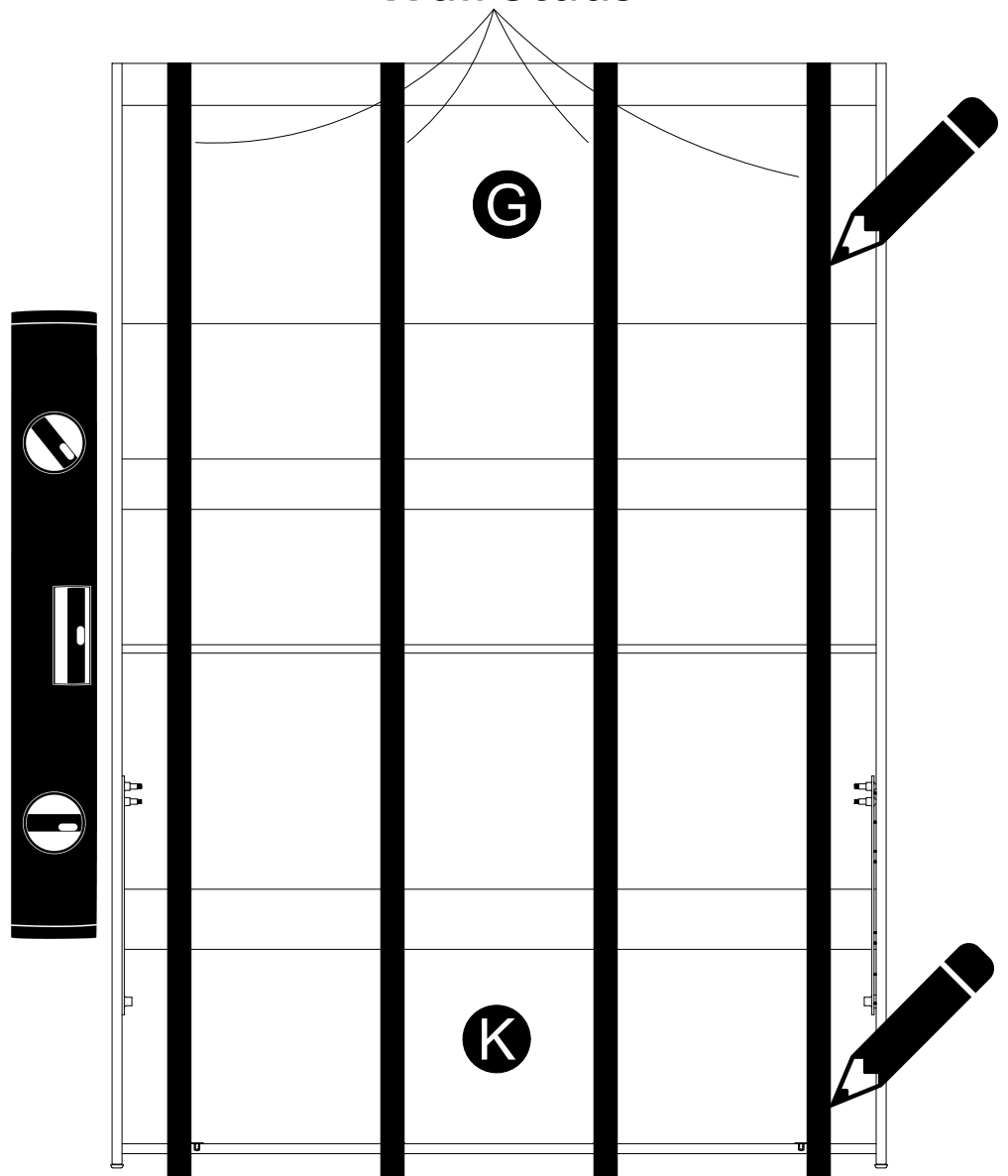
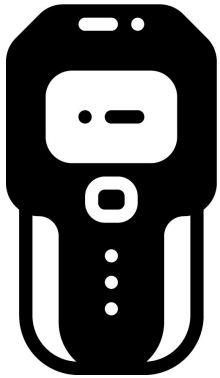

**A ladder will be required  
Do not lean against the  
top of the unit, it may  
cause sagging**

# STEP 29

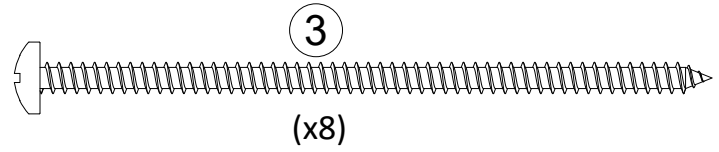

**First, make sure that your unit is still level in all directions.**

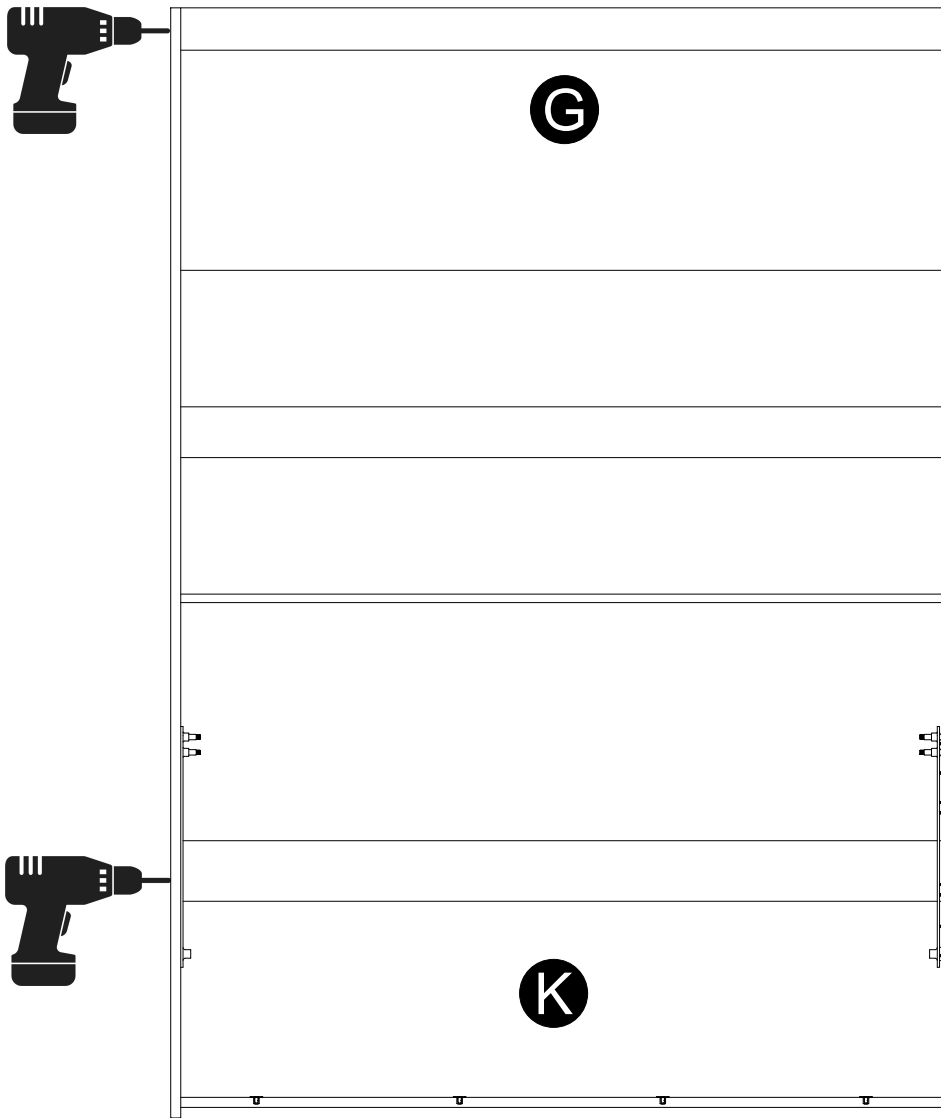

Drill 1/8" (3mm) pilot holes through the Upper Back Panel (G) and Bottom Stringer (K) at the stud locator marks. Fasten the unit to the studs in the wall with the Screws (3).



**A ladder will be required  
Do not lean against the  
top of the unit, it may  
cause sagging**

**The next steps are to assemble the metal bed  
frame and mechanism**

**These parts are located in the #3678096COM  
Wall Bed Mechanism Carton**

# STEP 30

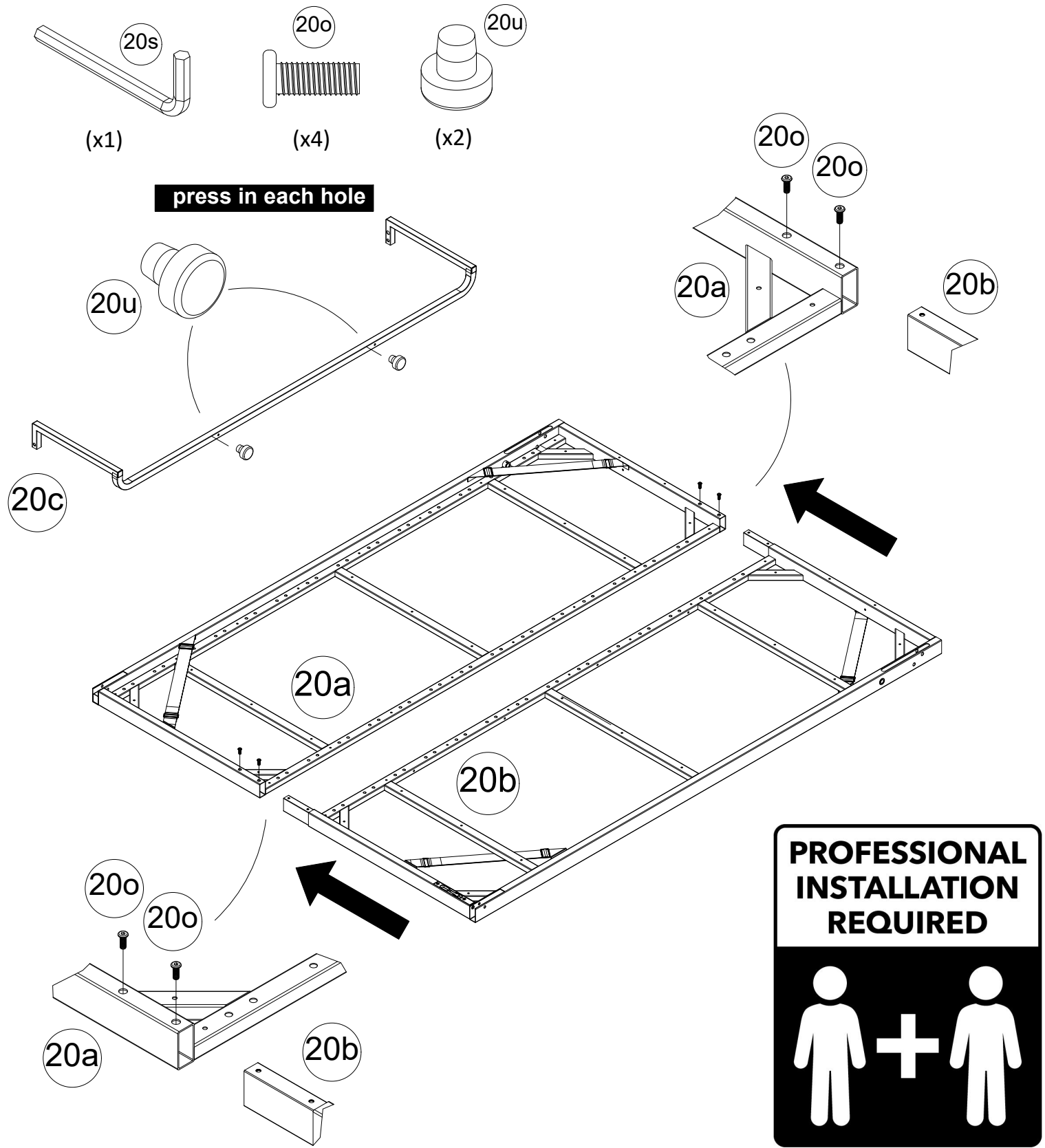



# STEP 31

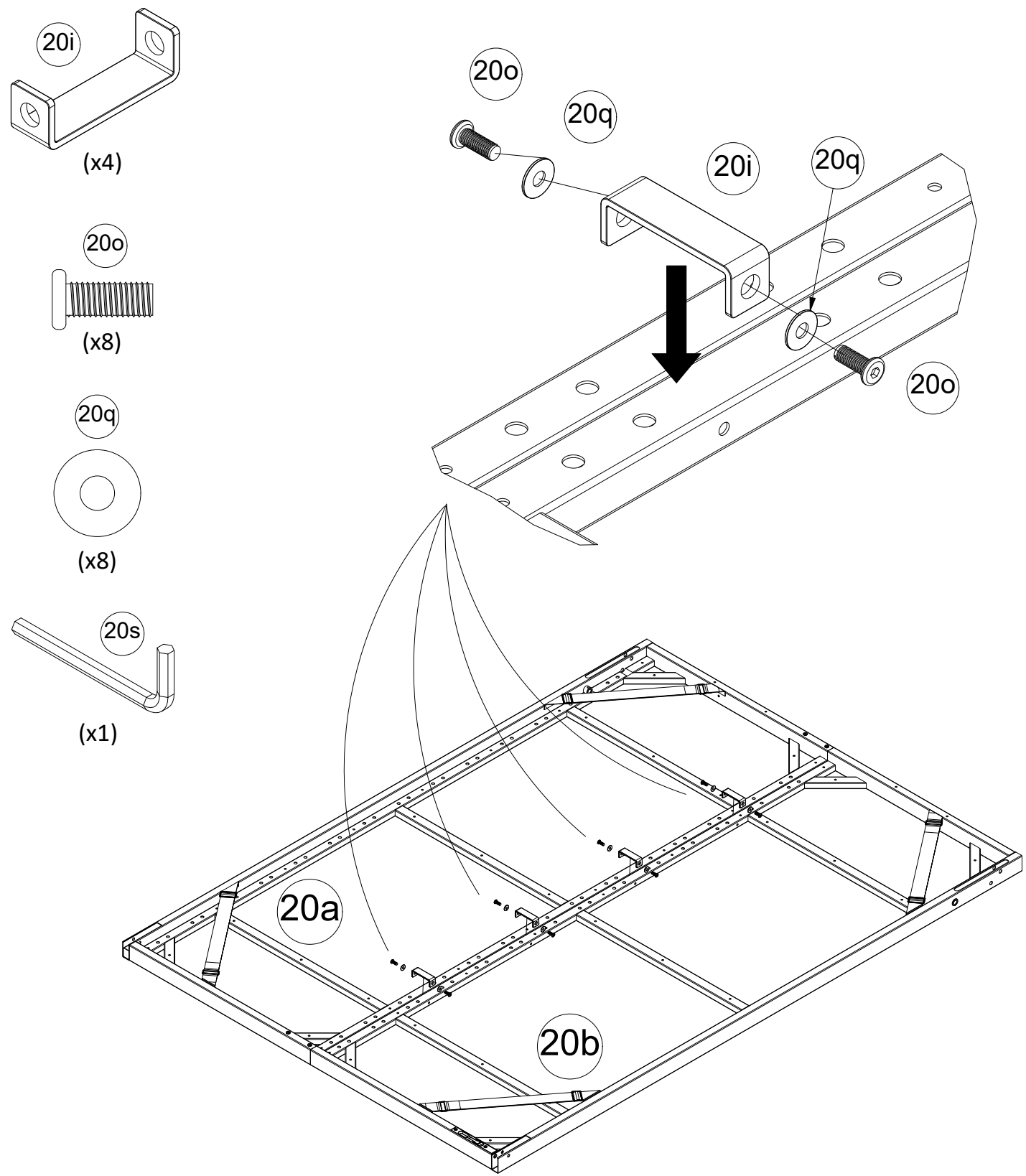

# STEP 32

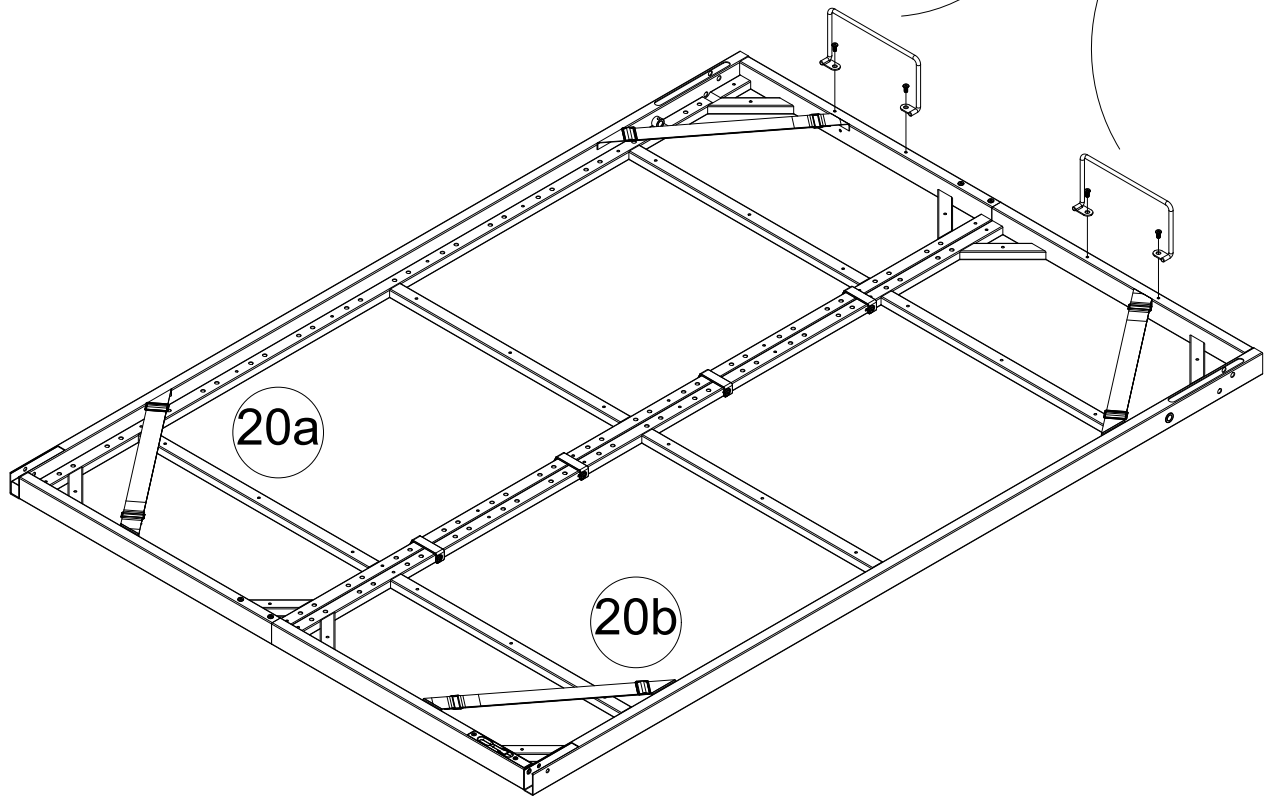
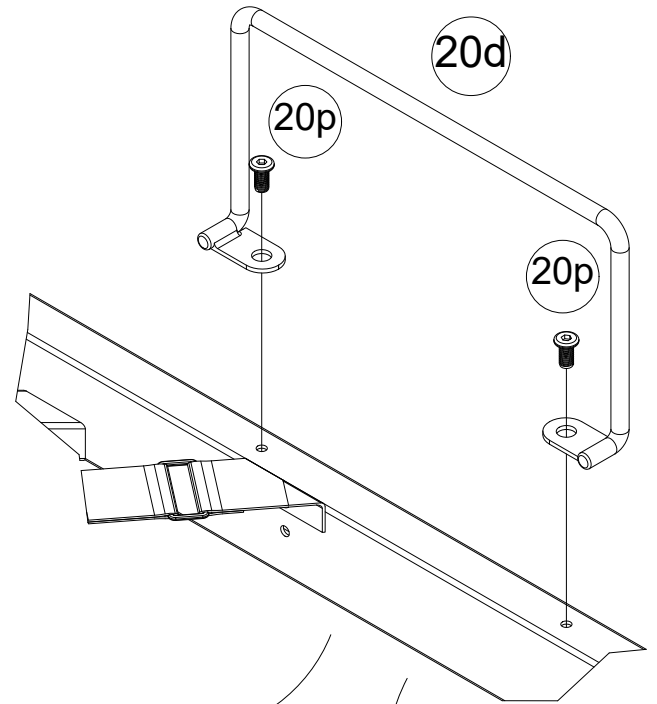
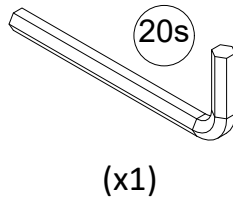
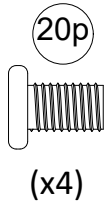
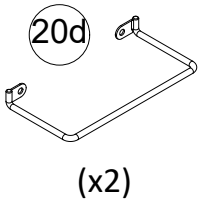

**STEP 33**

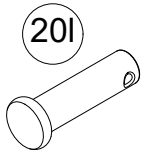

(x4)

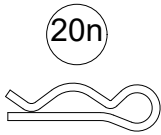

(x4)

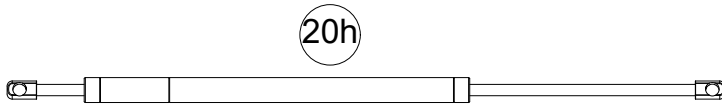

(x4)

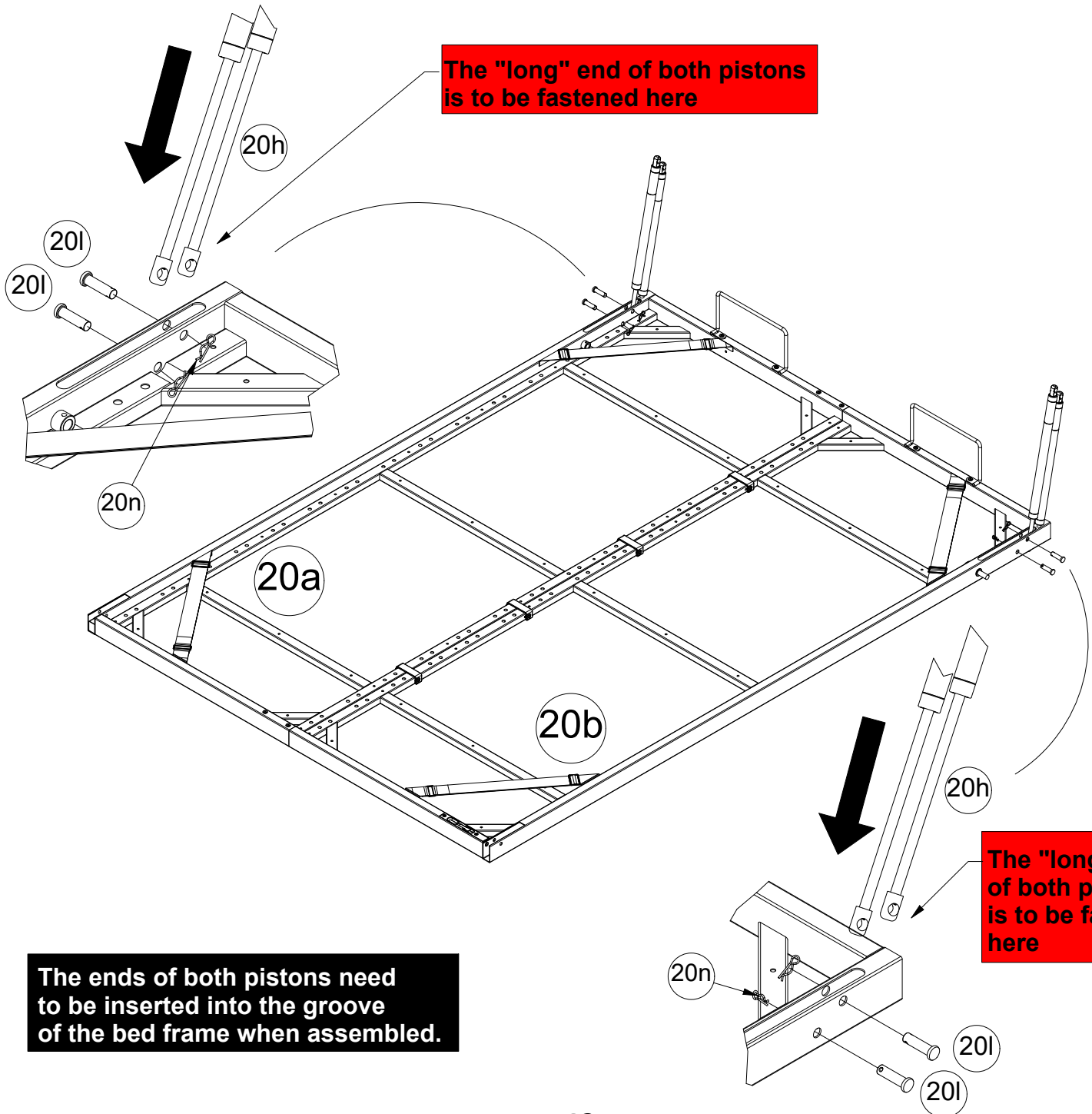

The "long" end of both pistons is to be fastened here

The "long" end of both pistons is to be fastened here

The ends of both pistons need to be inserted into the groove of the bed frame when assembled.

## STEP 34

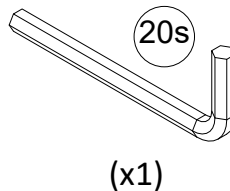
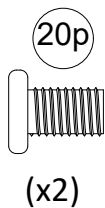
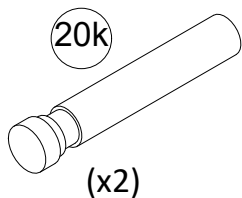
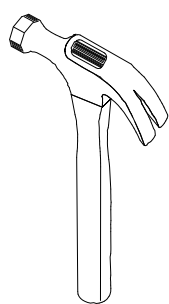

**PROFESSIONAL  
INSTALLATION  
REQUIRED**

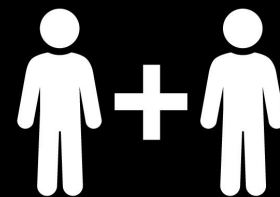

Already fastened to your unit

**The cabinet is not shown to allow a clear view of the bed frame assembly**

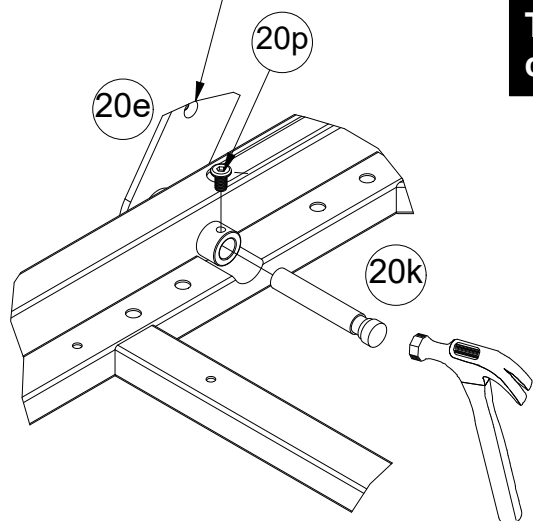

With a person on each side, lift the bed mechanism, line up the holes of the Bed Assembly with the large bushing hole of the Left and Right Pivot arm (20e & 20f) already installed to your unit, and insert the Pivot Pins (20k) as shown. Secure the pivot pins with a 10mm Bolt (20p).

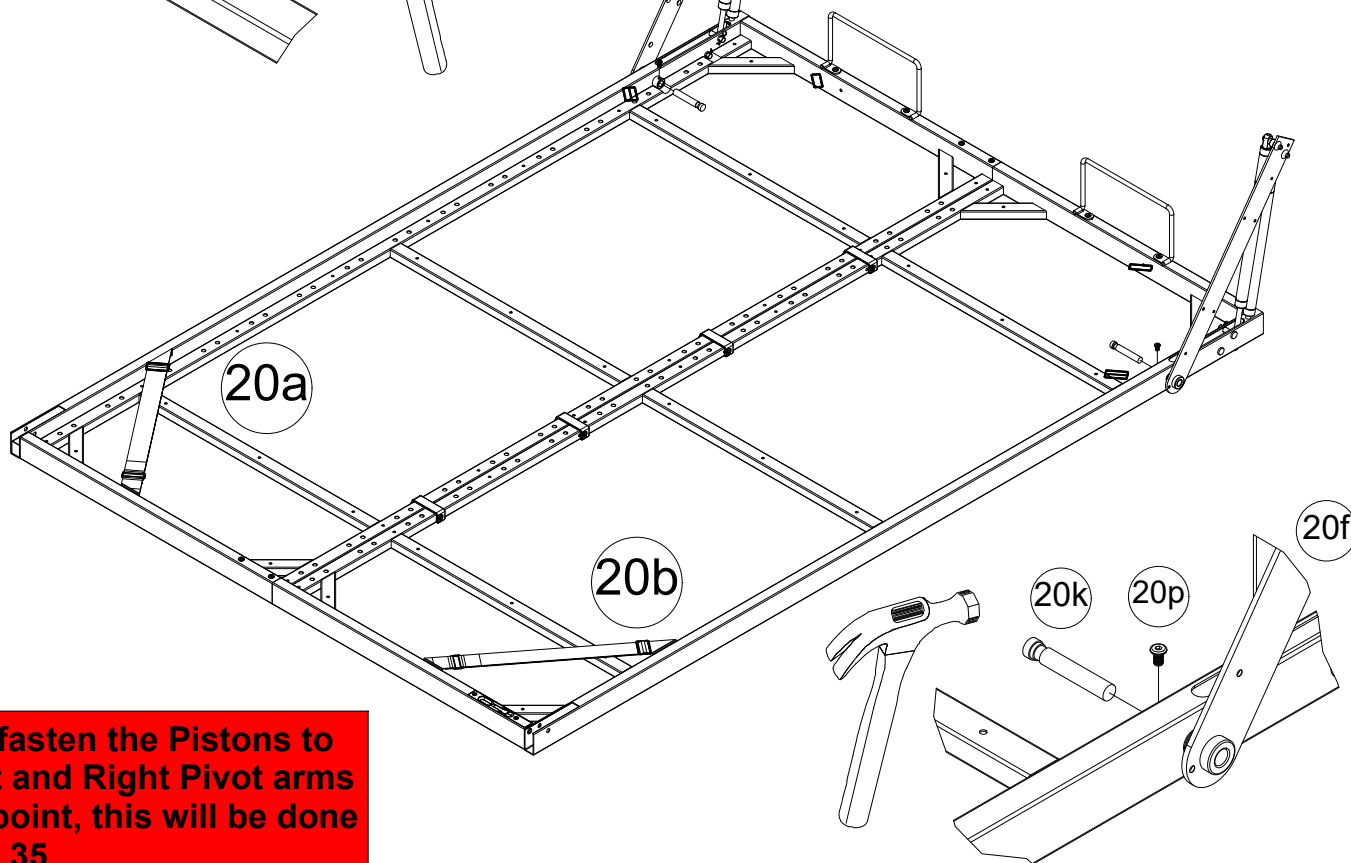

**Do not fasten the Pistons to the Left and Right Pivot arms at this point, this will be done on step 35**

# STEP 35

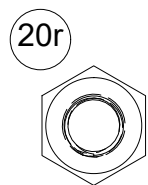

(x4)

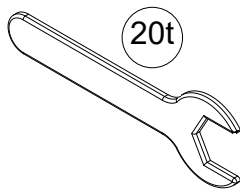

(x1)

**PROFESSIONAL  
INSTALLATION  
REQUIRED**

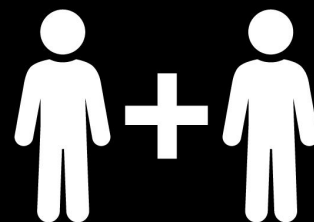

With a person on each side, carefully lift the bed frame in the closed position. While one person pushes the bed frame into the cabinet, passed the 90 degrees, the other person is to engage the "front" Gas Piston (20h) on each side of the unit, to the front pin of the Left and Right Pivot Arm (20e & 20f). Then tightly secure with two Nuts (20r).

To engage the "rear" Gas Piston (20h) on each side of the unit, slowly and carefully wiggle the bed frame back and forth until you can insert the Gas Pistons (20h) onto the rear pin of the Left and Right Pivot Arm (20e & 20f). Then tightly secure with two Nuts (20r).

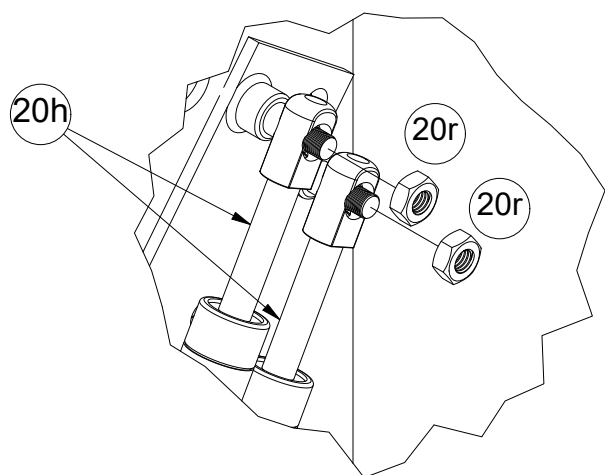
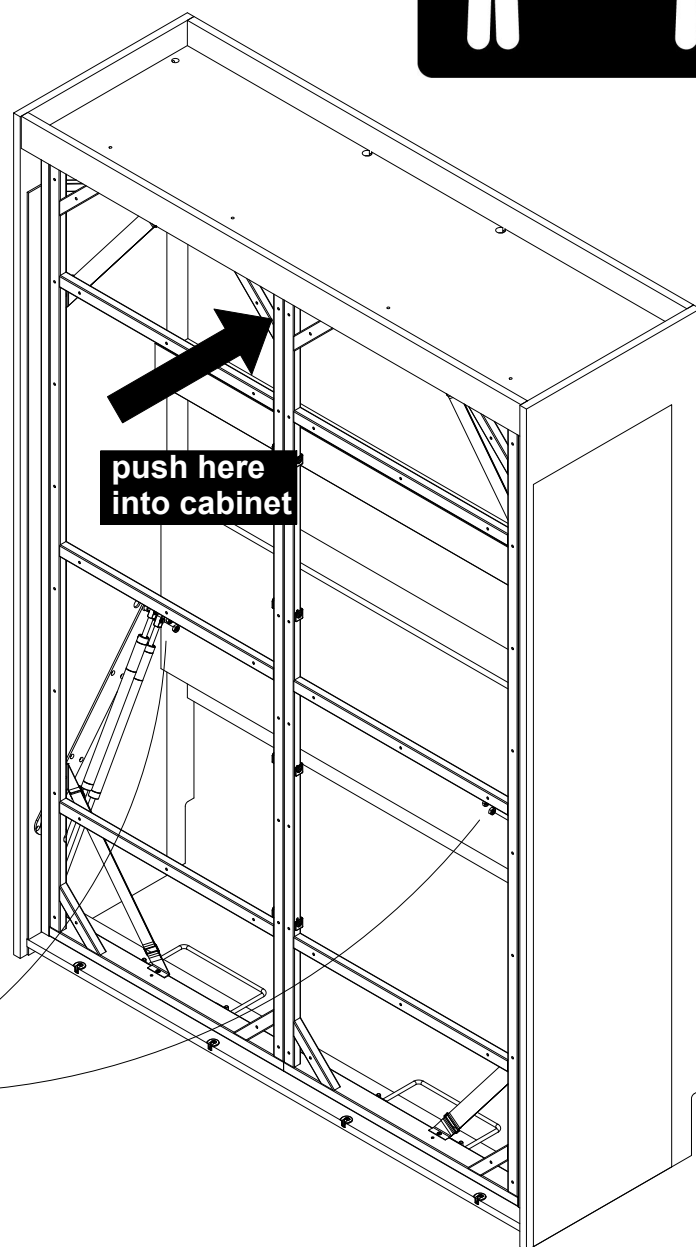

## STEP 36

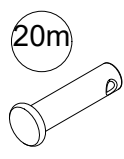

(x2)

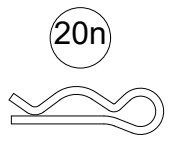

(x2)

14

ATTENTION / ATENCION / ATTENTION

(x1)

**PROFESSIONAL  
INSTALLATION  
REQUIRED**



The cabinet is not shown to allow a clear view of the bed frame assembly

Pull the bed frame down, then attach Leg (20c) as shown

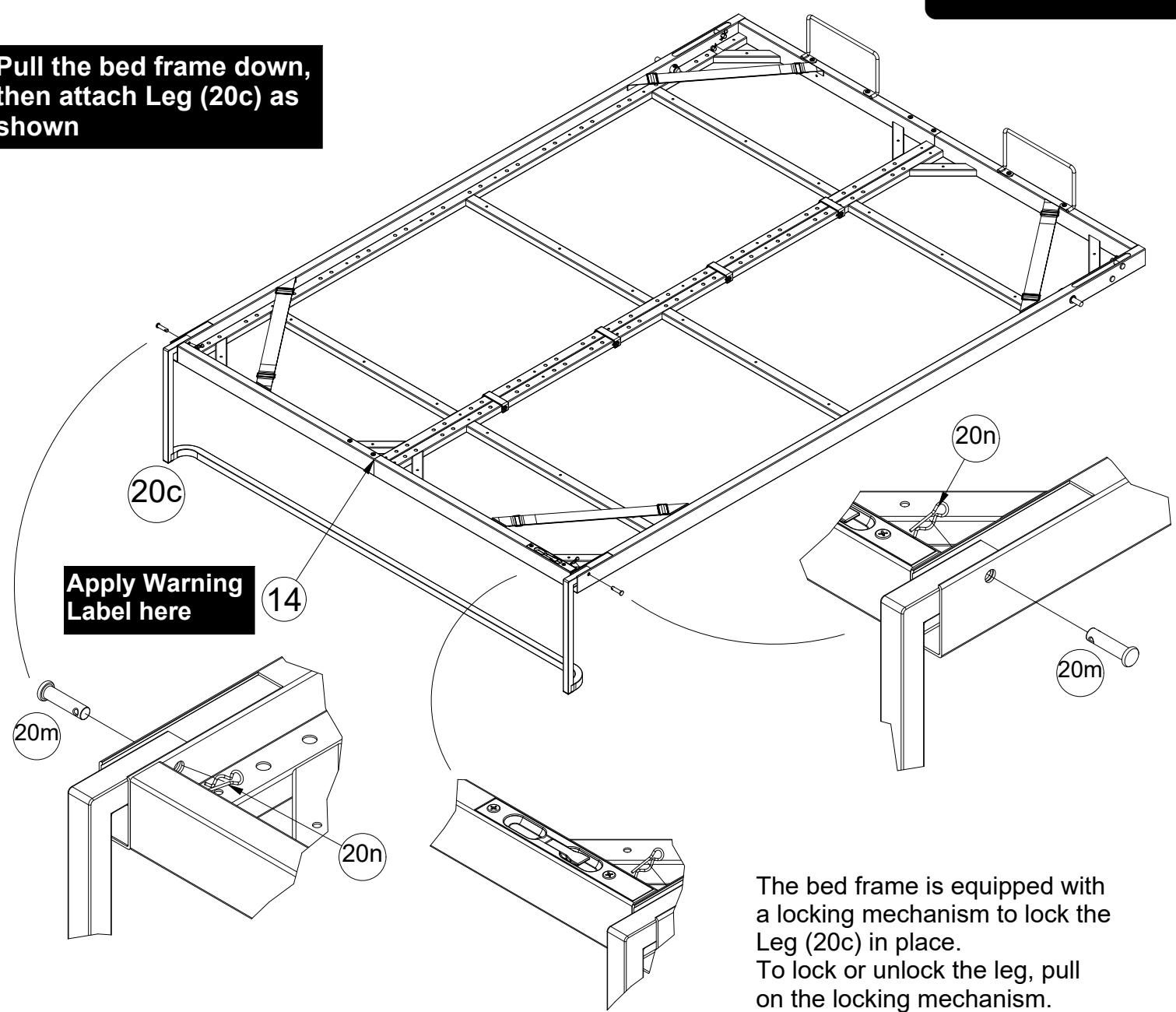

The bed frame is equipped with a locking mechanism to lock the Leg (20c) in place. To lock or unlock the leg, pull on the locking mechanism.

# STEP 37

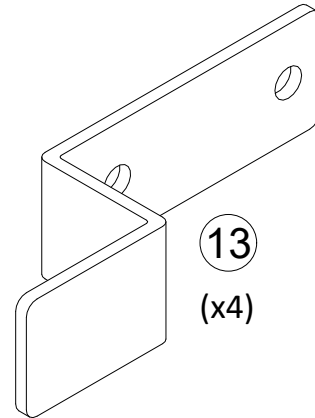
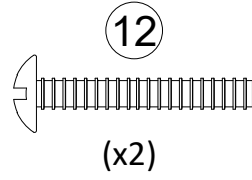
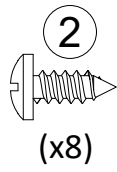
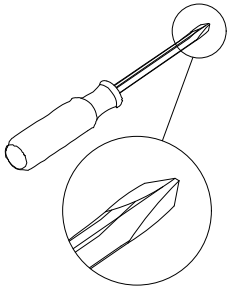

Proper orientation of bracket

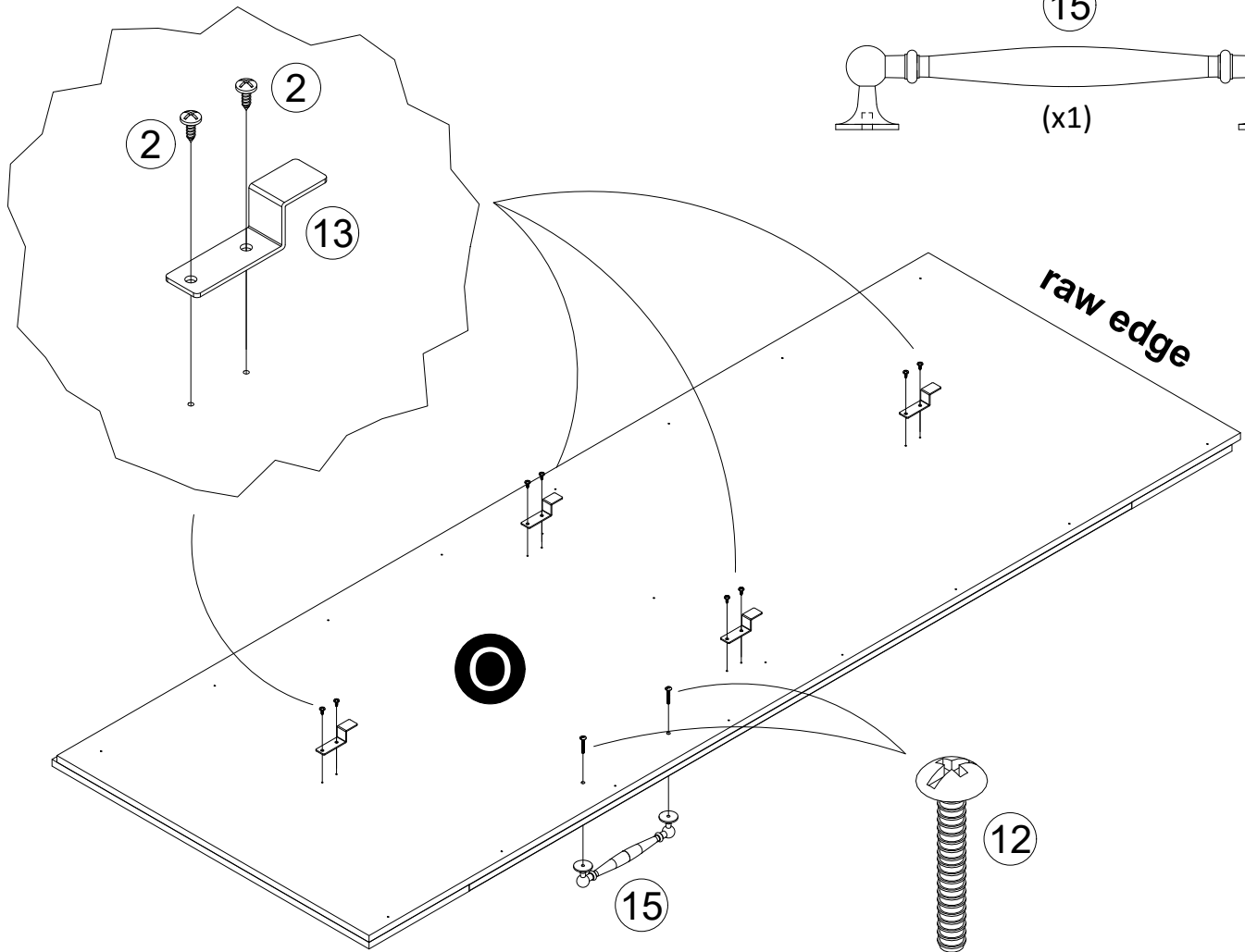
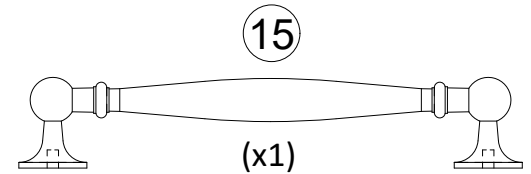

**STEP 38**

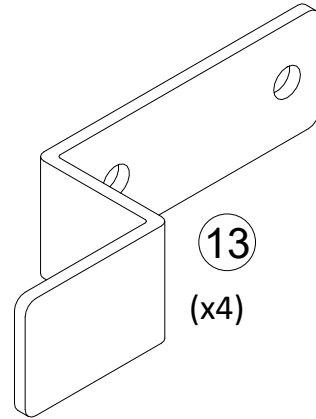
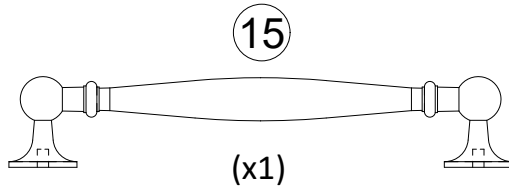
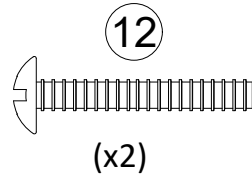
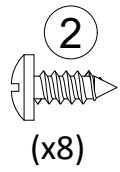
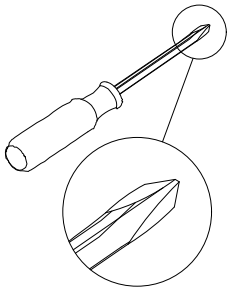

Proper orientation of bracket

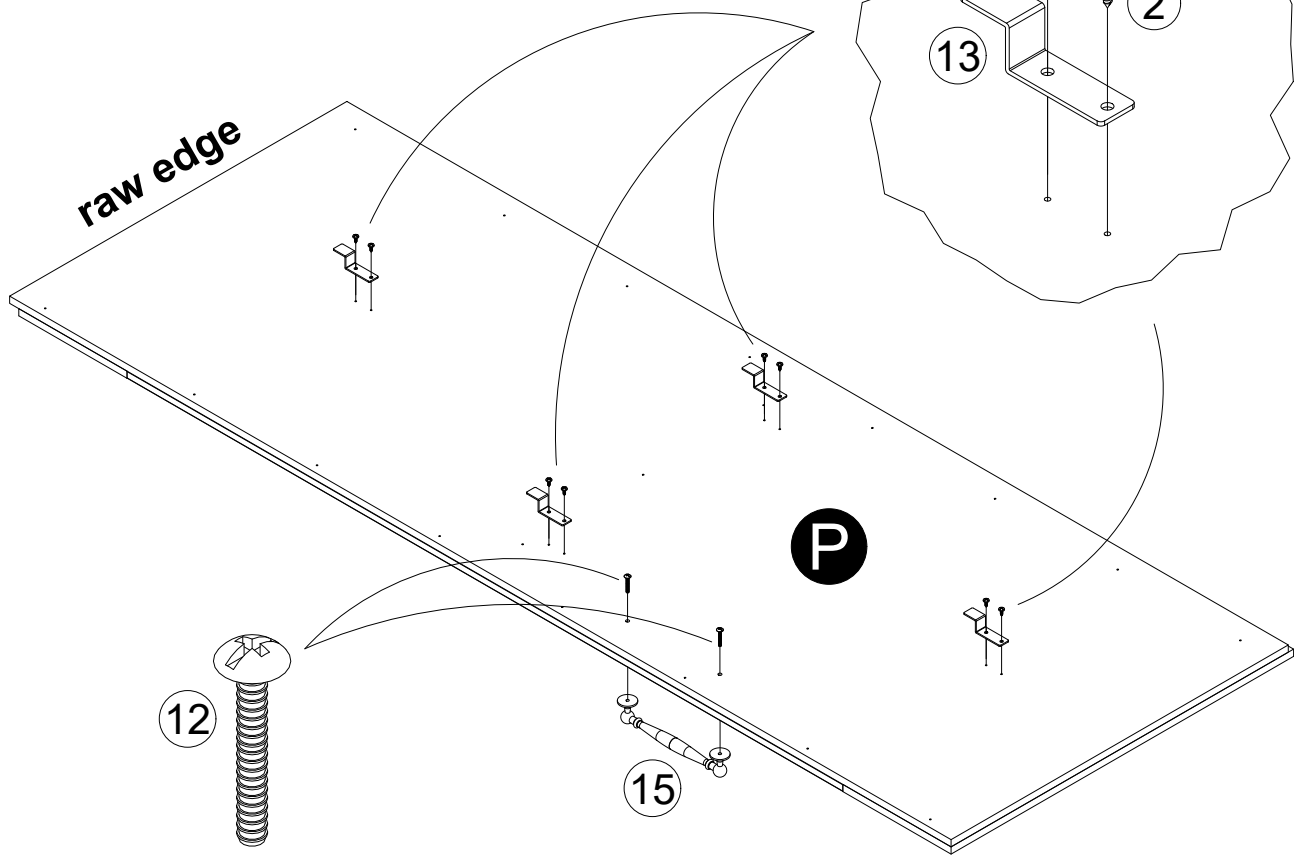
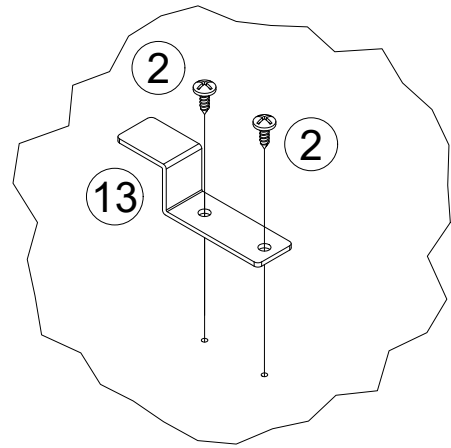



# STEP 39

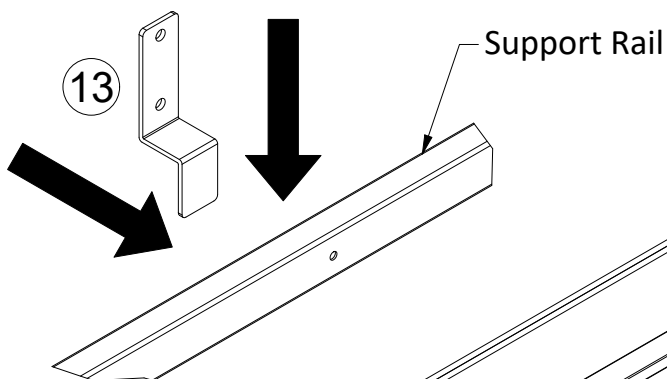

With the help of another person, lift the Left Door Assembly (O), position the Brackets (13) over the three Support Rails of the Bed Frame, and drop into position. Repeat the procedure for the Right Door Assembly (P).

**IMPORTANT:**  
First, unlock and flip the leg into the cabinet.  
Then, lower the bed frame down a bit to allow clearance to hook Door Assemblies (O&P).

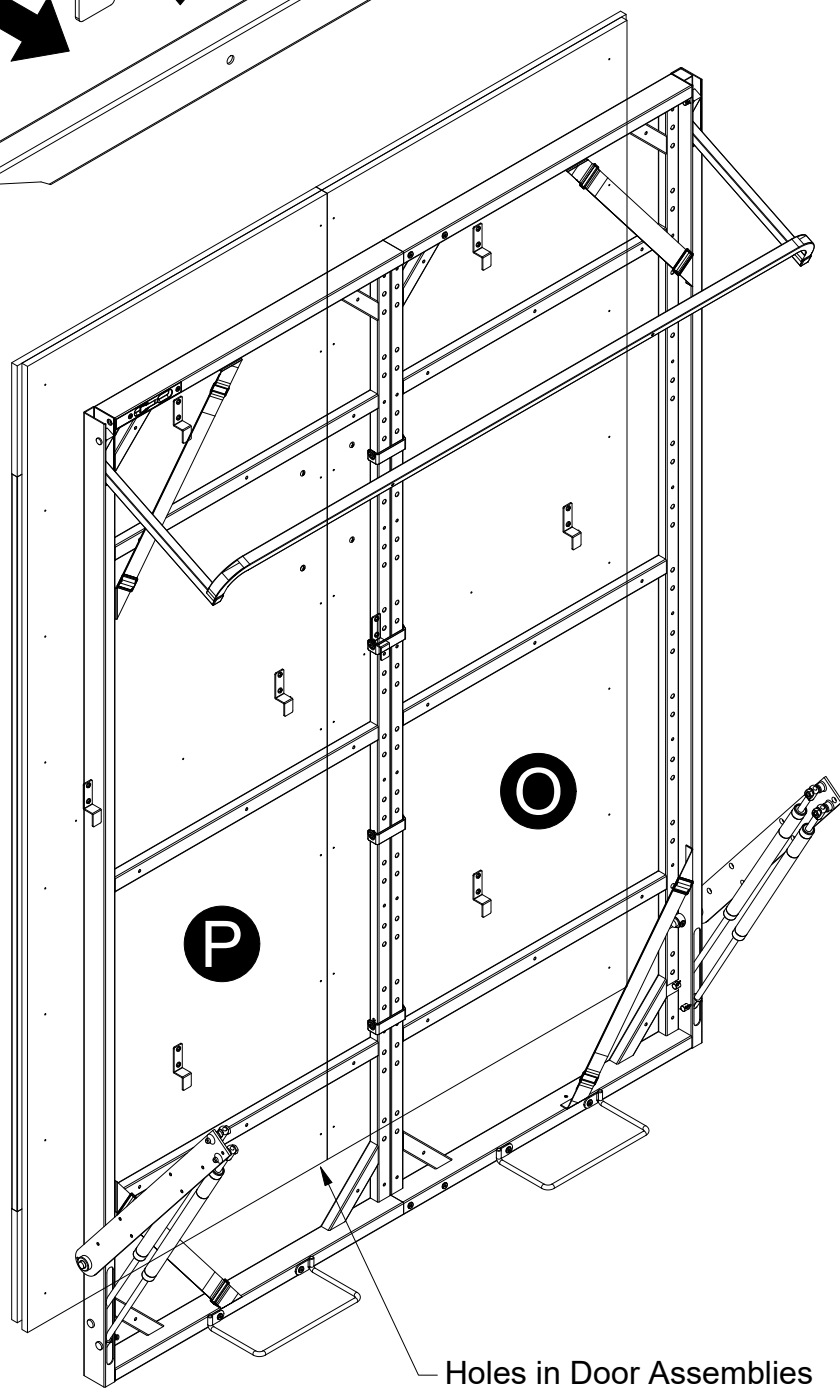

Holes in Door Assemblies (O&P) will be closer to each other at the center

The cabinet is not shown to allow a clear view of the bed frame assembly

# STEP 40

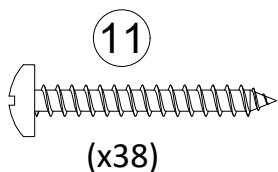
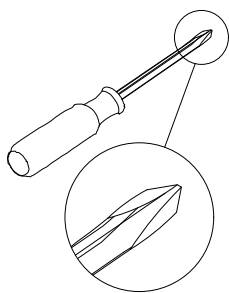

**With the help of another person, carefully pull the bed frame open**

Line up the holes of the bed frame with the holes in Door Assemblies (O&P), and fasten with Screws (11).

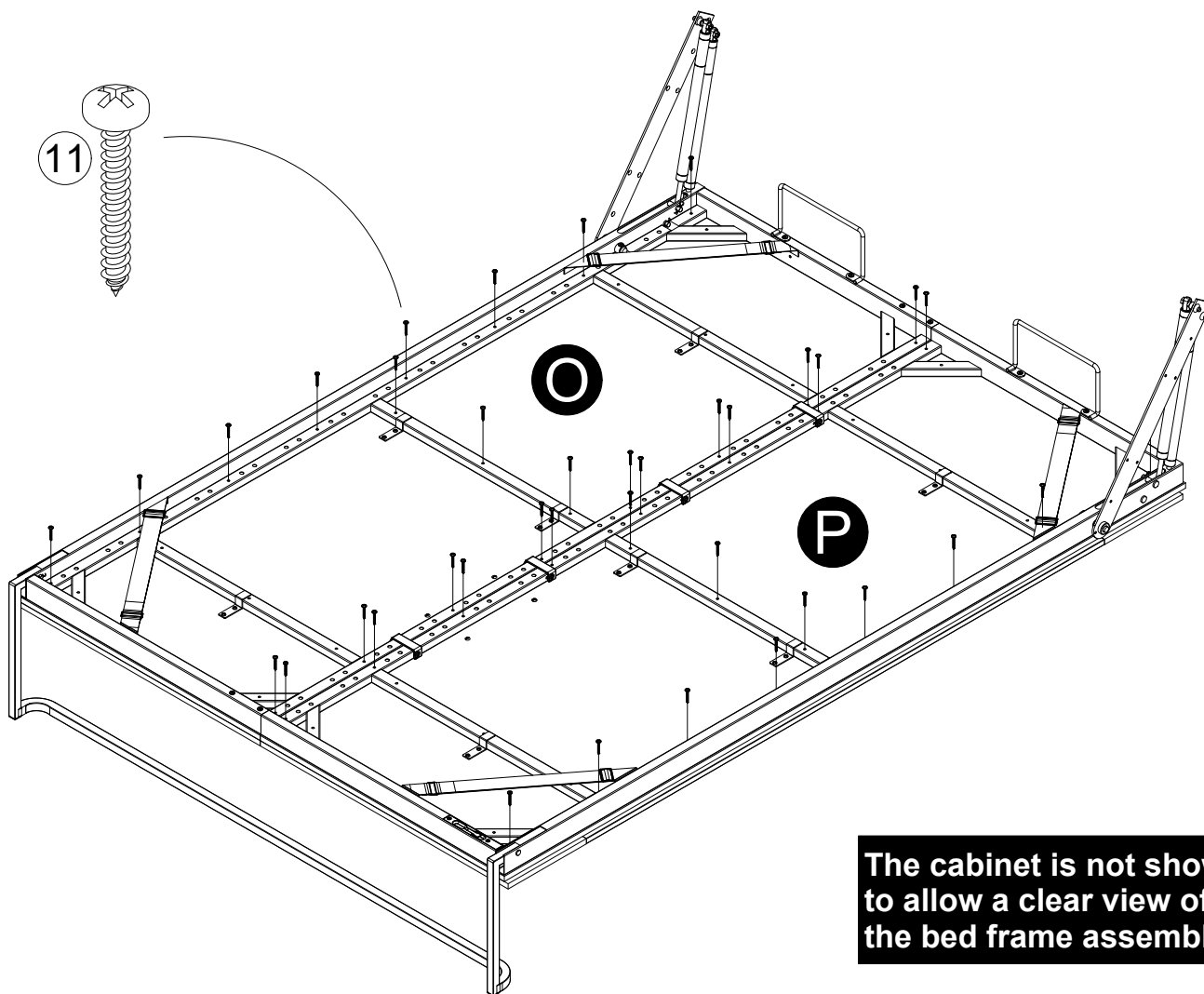

The cabinet is not shown to allow a clear view of the bed frame assembly

## STEP 41

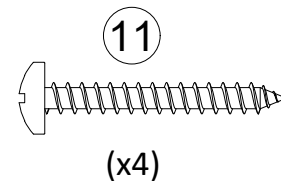
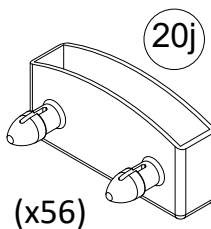
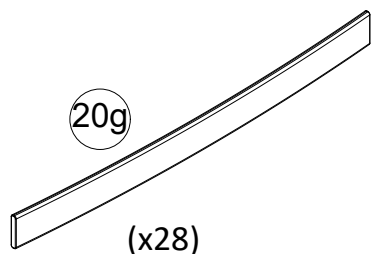
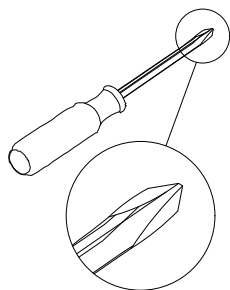

**A ladder will be required  
Do not lean against the  
top of the unit, it may  
cause sagging**

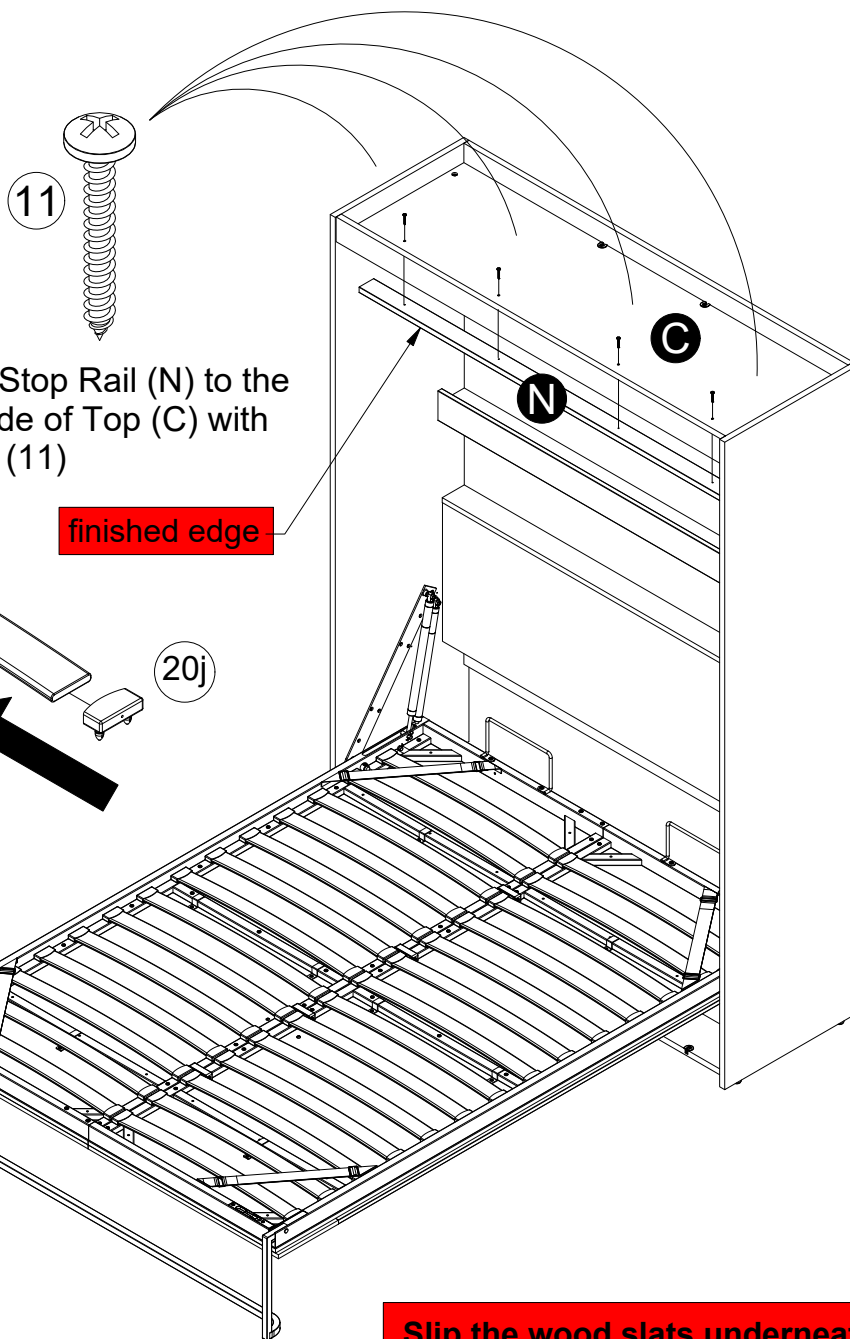

Fasten Stop Rail (N) to the underside of Top (C) with Screws (11)

**finished edge**

Press a Plastic Cap (20j) at each end of a Wood Slat (20g). Press both Plastic Caps (20j), attached to the Wood Slat, into the holes of the Metal Bed Frame. Repeat the procedure for all 28 wood slats and 56 plastic caps.

**PROFESSIONAL  
INSTALLATION  
REQUIRED**

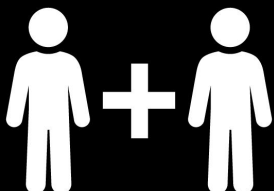

**Slip the wood slats underneath the straps at each corner**

# STEP 42

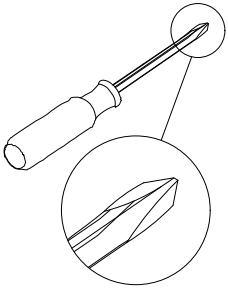

**Front of unit is not shown to allow a clear view of the kick and bottom**

While one person slightly opens the bed frame and holds it in place, insert the connector bolts installed in the Kick (F) into the connectors of the Bottom (D). Turn the connectors clockwise to lock in place.



Turn clockwise to lock in place

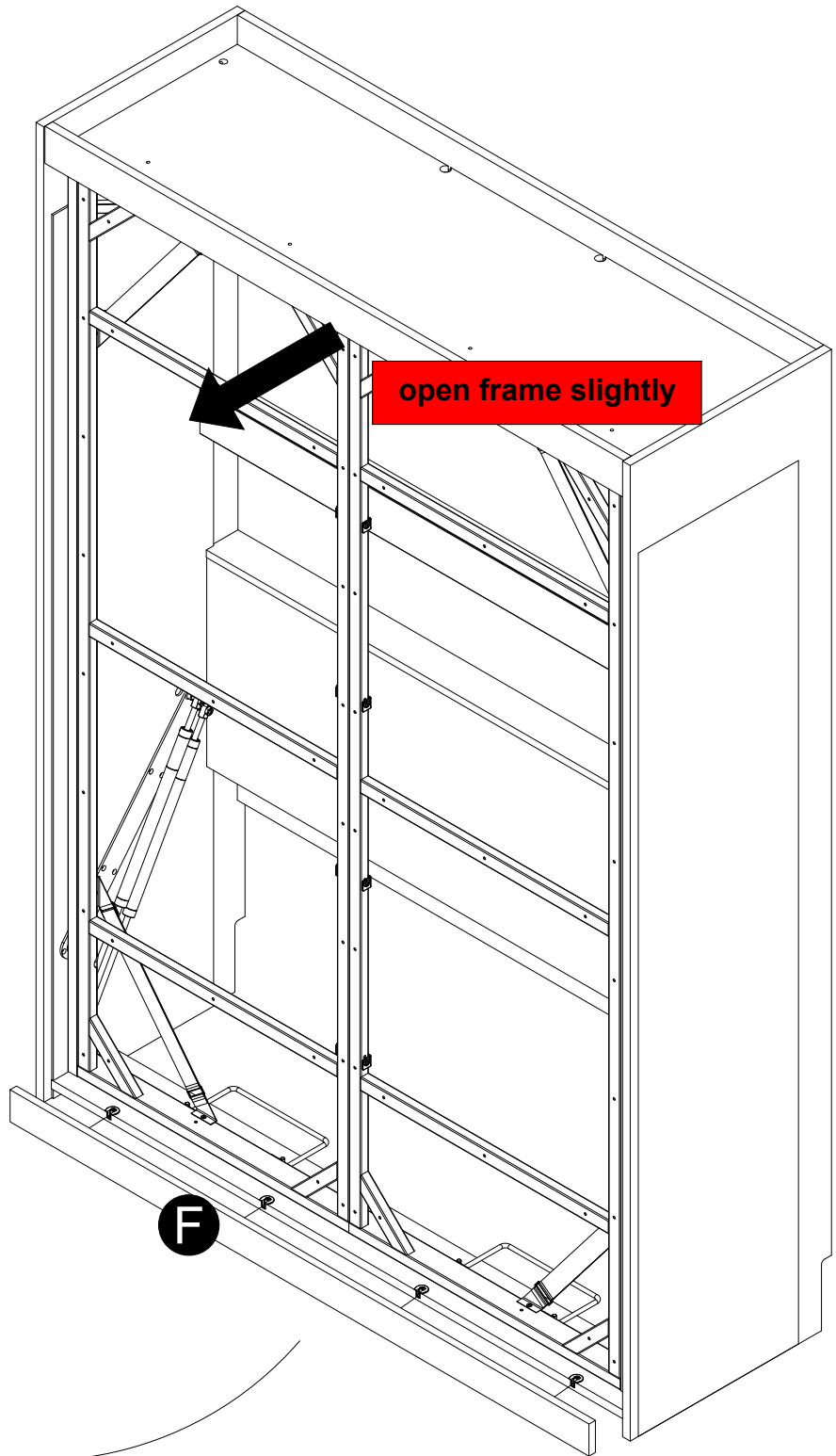
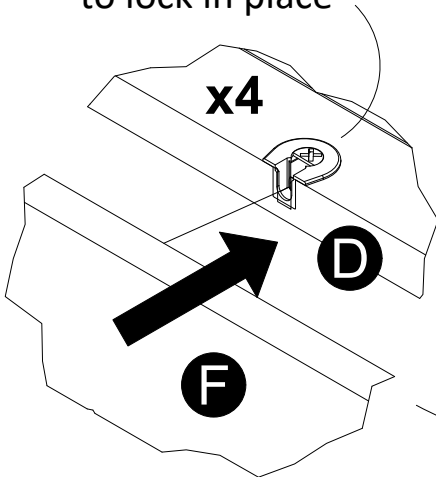

# Maximum Loads

This unit has been designed to support the maximum loads shown. Exceeding these load limits could cause sagging, instability, product collapse, and/or serious injury.

This bed is designed to accommodate a Full Size Mattress, up to 10" inches thick.

\* with a maximum weight of 60 lbs (27.2 kgs)

\* with a minimum weight of 30 lbs (13.6 kgs)

After you have finished assembling your wall bed, please keep the assembly manual by placing it under the mattress, in the frame of the mobile part of the bed.

**Caution**

**Two people may be required to open and close the bed**

Once you've placed your fitted sheet onto your mattress, secure your mattress with the straps provided in all 4 corners of the bed frame.

Keep the bed closed when not in use. It is recommended not to leave pillows and/or ornamental pillows in place when the bed is closed to preserve the mechanism.

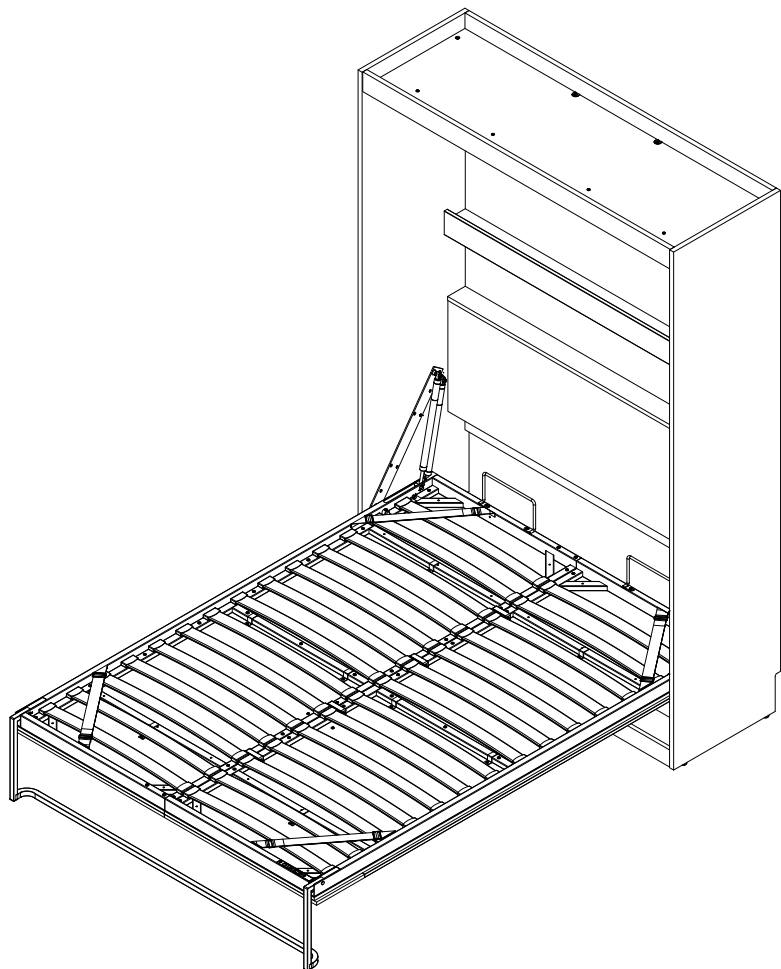

---

## Register your product to receive the following:



- \* New trend details - sneak peek on what's new
- \* Surveys - have a voice within our community
- \* Exclusive deals and discount codes
- \* Quick and easy replacement part service

To register your product, visit [ameriwoodhome.com](http://ameriwoodhome.com)

## *5 Star Rating*



Visit your local retailer's website, rate your purchased product and leave us some feedback!

*Thank  
You!*

# Español

## Cubierta Delantera

Este libro de instrucciones contiene información **IMPORTANTE** de seguridad. Por favor lea y manténgalo para referencia en el futuro.

**No Regrese este producto!** Comuníquese con nuestro amigoso equipo de servicio al cliente para obtener ayuda.

Llámenos al: 1-800-489-3351 (Gratis)

Visitar: [www.ameriwoodhome.com](http://www.ameriwoodhome.com)

## PRECAUCION

Este mueble puede volcarse y causar graves heridas y/o muerte.

Anclar el mueble a un poste de madera en la pared (si esto se requiere).

No Permita que los niños monten el mueble.

Mantenga los artículos más pesados en los cajones de abajo.

**Se requiere instalación profesional para esta unidad.**

## Consejos Útiles (página 2)

- Abra su artículo en el área donde usted planea utilizarlo para evitar levantar y moverlo menos
- Identificar, ordenar y contar las piezas antes de intentar ensamblar
- Las clavijas de compresión se golpean con un martillo
- Las diapositivas están marcadas con una R (derecha) y L (izquierda) para la colocación correcta
- Asegúrese de que siempre este el punto localizado en la parte superior de bloqueador de leva este volteado hacia borde exterior
- Utilizar todos los clavos para el panel de atrás y distribuirlos por igual
- El panel de atrás debe utilizarse para asegurarse de que la unidad quede fija y firme
- No use químicas fuertes ni limpiadores abrasivos en este artículo
- Nunca empuje, tire ni arrastre los muebles

## Antes de Que Empieces (página 3)

- Lea cuidadosamente cada paso y siga el orden correcto
- Separar y contar todas sus piezas y hardware
- Dése suficiente espacio para el proceso de ensamble
- Tenga las siguientes herramientas: destornillador de cabeza plana, #2 cabeza Phillips Destornillador y martillo
- Precaución: Si usa un taladro electrónico o un destornillador eléctrico para atornillar, por favor asegúrese que deje de atornillar cuando el tornillo este apretado. Fallar hacer esto puede causar barrer el tornillo.

## Sistema de fijar el bloqueo de leva (página 3)

Esta sistema de fijar el bloqueo de leva sera usado en todo el proceso ensamble.

## Página 6

Tenga en cuenta que su unidad puede contener hardware adicional

**Página 7**

Nota: No se identificarán todas las piezas.

**Página 8**

Antes de comenzar, se requiere una instalación profesional ¡Cuidado! Si no se utilizan 2 profesionales para este montaje, podría haber daños en la unidad o lesiones personales

**Página 9, 10, 11, 12, 14, 17**

orientación adecuada del bloqueo de la leva  
dale la vuelta  
orientación adecuada del conector

**Página 19**

el brazo de pivote izquierdo (20e) se encuentra en la caja del mecanismo de cama de pared 3678096COM

**Página 21**

el brazo de pivote derecho (20f) se encuentra en la caja del mecanismo de cama de pared 3678096COM

**Página 22, 23, 24, 25**

gire en el sentido de las agujas del reloj para bloquear en su lugar  
borde crudo

**Página 29**

El bloqueo de leva está más cerca del borde aquí

**Página 31**

borde crudo

**Página 33**

coloque la unidad sobre su frente  
Golpee los bujes (7) con un martillo  
Atornille los deslizadores (6) completamente



**Página 34**

Las siguientes instrucciones son para ensamblar su unidad en la pared:

La unidad ensamblada DEBE estar nivelada en altura, ancho y profundidad para funcionar correctamente.

La unidad ensamblada DEBE colocarse plana contra la pared.

La unidad ensamblada DEBE atornillarse en 3 montantes de pared DIFERENTES en la parte superior e inferior para mayor seguridad.

Los tornillos proporcionados son para paneles de yeso y montantes de madera. Si las paredes son de mampostería, concreto u otros materiales de pared, utilice el hardware apropiado para fijar su unidad de manera segura a la pared.

NO utilice anclajes de pared para fijar su unidad a la pared.

¡No se recomienda mover la unidad después de ensamblarla!

**Página 35**

Coloque su unidad al ras contra la pared

Hay muescas en la parte posterior de su unidad.

Estas muescas deben encajar alrededor del zócalo de la pared.

Si su zócalo es más alto o más grueso que las muescas provistas en la unidad, deberá quitar el zócalo, cortarlo para que quepa en ambos lados de su unidad y luego volver a fijarlo a la pared.

**Página 36**

La unidad ensamblada DEBE estar nivelada en altura, ancho y profundidad para funcionar correctamente.

Si es necesario, desatornille los deslizadores en sentido antihorario según sea necesario en las cuatro esquinas hasta que su unidad esté nivelada en todas las direcciones.

Se requerirá una escalera

No se apoye contra la parte superior de la unidad, puede causar flacidez

**Página 37**

Ubique los montantes en la pared, usando un buscador de montantes.

Con un lápiz, marque las ubicaciones de los montantes en la superficie superior del panel posterior superior (G).

Con un nivel, lleve las ubicaciones de los montantes hasta el larguero inferior (K) y, con un lápiz, marque las ubicaciones de los montantes.

Necesita ubicar al menos 3 postes, pero 4 es mejor

Se requerirá una escalera

No se apoye contra la parte superior de la unidad, puede causar flacidez

**Página 38**

Primero, asegúrate de que tu unidad esté nivelada en todas las direcciones. Luego, taladra agujeros piloto de 1/8" (3 mm) a través del Panel Posterior Superior (G) y el Travesaño Inferior (K) en las marcas del localizador de montantes. Fija la unidad a los montantes de la pared con los tornillos (3). Será necesario usar una escalera. No te apoyes en la parte superior de la unidad, ya que podría provocar que se hunda.

**Página 39**

Los siguientes pasos son ensamblar el marco y el mecanismo de la cama de metal. Estas piezas se encuentran en la caja de cartón del mecanismo de cama mural #3678096COM.

**Página 40**

presione en cada agujero

**Página 43**

El extremo "largo" de ambos pistones debe fijarse aquí.

Los extremos de ambos pistones deben insertarse en la ranura del marco de la cama cuando se ensamblan.

**Página 44**

Ya fijado a su unidad

Con una persona a cada lado, levante el mecanismo de la cama, alinee los orificios del conjunto de la cama con el orificio del buje grande del brazo de pivote izquierdo y derecho (20e y 20f) ya instalado en su unidad e inserte los pasadores de pivote (20k) como se muestra.

Asegure los pasadores de pivote con un Perno de 10mm (20p).

El gabinete no se muestra para permitir una vista clara del ensamblaje del marco de la cama. No sujete los pistones a los brazos de pivote izquierdo y derecho en este punto, esto se hará en el paso 35.

**Página 45**

Con una persona a cada lado, levante con cuidado el marco de la cama en la posición cerrada. Mientras una persona empuja el armazón de la cama dentro del gabinete, pasando los 90 grados, la otra persona debe enganchar el pistón de gas delantero (20h) a cada lado de la unidad, al pasador delantero del brazo de pivote izquierdo y derecho (20e y 20f). Luego asegúrelo firmemente con dos tuercas (20r). Para acoplar el pistón de gas trasero (20h) a cada lado de la unidad, mueva lenta y cuidadosamente el marco de la cama hacia adelante y hacia atrás hasta que pueda insertar los pistones de gas (20h) en el pasador trasero del brazo de pivote izquierdo y derecho (20e y 20f). Luego asegúrelo firmemente con dos tuercas (20r).

Empuje aquí en el gabinete

**Página 46**

El gabinete no se muestra para permitir una vista clara del ensamblaje del marco de la cama

Jale el marco de la cama hacia abajo, luego conecte la Pata (20c) como se muestra

El armazón de la cama está equipado con un mecanismo de bloqueo para bloquear la Pata (20c) en su lugar. Para bloquear o desbloquear la pierna, tire del mecanismo de bloqueo.

Aplicar la etiqueta de advertencia aquí

**Página 47**

Orientación adecuada del soporte  
borde crudo

**Página 48**

Orientación adecuada del soporte  
borde crudo

**Página 49**

Carril de soporte

Con la ayuda de otra persona, levante la Asamblea de la Puerta Izquierda (O), coloque los soportes (13) sobre los tres rieles de soporte del marco de la cama y colóquelos en su posición.

Repita el procedimiento para el conjunto de la puerta derecha (P).

**IMPORTANTE:** Primero, desbloquee y coloque la pata en el gabinete. Luego, baje un poco el marco de la cama para permitir que quede espacio libre para enganchar los ensamblajes de puertas (O y P).

El gabinete no se muestra para permitir una vista clara del ensamblaje del marco de la cama

Los agujeros en los paneles de las puertas (O y P) estarán más cerca entre sí en el centro

**Página 50**

Con la ayuda de otra persona, abra con cuidado el marco de la cama.

Alinee los orificios del armazón de la cama con los orificios de los paneles (O y P) y fíjelos con tornillos (11).

El gabinete no se muestra para permitir una vista clara del ensamblaje del marco de la cama

**Página 51**

Se requerirá una escalera

No se apoye contra la parte superior de la unidad, puede causar flacidez

Sujete el riel de tope (N) a la parte inferior de la parte superior (C) con tornillos (11)

Presione una tapa de plástico (20j) en cada extremo de un listón de madera (20g).

Presione ambas tapas de plástico (20j), unidas al listón de madera, en los orificios del marco de la cama de metal.

Repita el procedimiento para las 28 tablillas de madera y las 56 tapas de plástico.

Deslice los listones de madera debajo de las correas en cada esquina.

## **Página 52**

marco abierto ligeramente

La parte delantera de la unidad no se muestra para permitir una vista clara de la patada y el fondo. Mientras una persona abre ligeramente el armazón de la cama y lo mantiene en su lugar, inserte los pernos del conector instalados en la patada (F) en los conectores de la parte inferior (D). Gire los conectores en el sentido de las agujas del reloj para bloquearlos en su lugar. Gire en sentido horario para bloquear en su lugar

## **Página 53**

**CARGA MAXIMA**

Esta unidad ha sido diseñada para soportar la carga máxima anotada. El exceder estos límites puede causar inestabilidad, colapsarse y/o causar serias lesiones.

Esta cama está diseñada para acomodar un colchón tamaño full, de hasta 10" pulgadas de grosor.

\* con un peso máximo de 60 libras (27.2 kgs)

\* con un peso mínimo de 30 libras (13.6 kgs)

Una vez que haya terminado de montar su cama abatible, conserve el manual de montaje colocándolo debajo del colchón, en el marco de la parte móvil de la cama.

Una vez que haya colocado su sábana ajustable en su colchón, asegure su colchón con las correas provistas en las 4 esquinas del marco de la cama.

Mantenga la cama cerrada cuando no esté en uso.

Se recomienda no dejar almohadas y / o almohadas ornamentales en su lugar cuando la cama está cerrada para preservar el mecanismo.

Más peso del colchón

## **Página 54**

Registre su producto para recibir lo siguiente:

- \* Detalles de nuevas tendencias - Vistazo a lo nuevo
- \* Encuestas - aloc su voz entre su comunidad
- \* Códigos de ofertas y descuentos exclusivos
- \* Fácil y rápido servicio de partes de remplazo

Para registrar su producto, visite [ameriwoodhome.com](http://ameriwoodhome.com)

Clasificación de 5 estrellas

Visite el sitio web de su tienda local, califique su comprado y denos sus comentarios!

Gracias

## Couverture Avant

CE LIVRET D'INSTRUCTION CONTIENT DES INFORMATIONS **IMPORTANTES** SUR LA SÉCURITÉ. VEUILLEZ LIRE ET GARDER POUR UNE RÉFÉRENCE FUTURE

**Ne retournez pas ce produit!** Contactez notre équipe de service à la clientèle amicale d'abord pour obtenir de l'aide.

**Appelez-nous:** 1-800-489-3351 (sans frais)

**Visitez:** [www.ameriwoodhome.com](http://www.ameriwoodhome.com)

## ATTENTION

Le meuble peut basculer et causer des blessures graves ou la mort.

Ancrer le meuble à une planche murale dans le mur (si indiqué).

Ne laissez pas les enfants grimper sur le meuble.

Placez les articles lourds sur les étagères ou dans les tiroirs inférieurs.

**Une installation professionnelle est requise pour cet appareil**

## Astuces Utiles (page 2)

-Ouvrez votre article dans la zone que vous prévoyez de le garder pour moins de levage lourd

-Identifier, trier et compter les pièces avant d'essayer d'assembler

-Les goujons de compression sont taraudés avec un Marteau

-Les glissières sont marquées d'un R (droit) et d'un L (gauche) pour un bon placement

-Assurez-vous toujours de faire face la pointe situé sur le haut de la Serrure de Came vers le bord extérieur

-Utiliser tous les clous fournis pour le panneau arrière et les répartir également

-Le panneau arrière doit être utilisé pour vous assurer que votre appareil est robuste

-N'utilisez pas de produits chimiques agressifs ou de nettoyeurs abrasifs sur cet appareil

-Ne jamais pousser, tirer, ou faire glisser votre meuble

## Avant de Commencer (page 3)

-Lisez attentivement chaque étape et suivez le bon ordre

-Séparez et comptez toutes vos pièces et matériaux

-Donnez-vous suffisamment de place pour l'assemblage

-Avoir les outils suivants: tournevis à tête plate, #2 tournevis Phillips, et Marteau

-Attention: Si vous utilisez une perceuse électrique ou un tournevis électrique pour visser, veillez à ralentir et arrêter lorsque la vis est bien serrée. Le non-respect de cette consigne peut endommager la vis.

## Système de Fixation de Came (page 3)

Ce Système de Fixation de Came sera utilisé tout au long de l'assemblage

## Page 6

Notez que votre appareil peut contenir du matériel supplémentaire

**Page 7**

Remarque: les pièces ne seront pas toutes identifiées.

**Page 8**

Avant de commencer ! Une installation professionnelle est requise. Attention : Ne pas faire appel à deux professionnels pour cet assemblage pourrait entraîner des dommages à l'unité ou des blessures personnelles

**Page 9, 10, 11, 12, 14, 17**

bonne orientation du verrou à came

retourner

bonne orientation du connecteur

**Page 19**

Le Bras Pivotant Gauche (20e) est situé dans le  
3678096COM Boîte de mécanisme de lit escamotable

**Page 21**

Le Bras Pivotant Droit (20f) est situé dans le  
3678096COM Boîte de mécanisme de lit escamotable

**Page 22, 23, 24, 25**

tourner dans le sens des aiguilles d'une montre pour verrouiller en place  
bord brut

**Page 29**

La verrou à came est plus proche du bord ici

**Page 31**

bord brut

**Page 33**

Posez l'appareil sur son devant

Taper les douilles (7) avec un marteau

Visser complètement les sous-pattes (6)

**Page 34**

Les prochaines étapes consistent à assembler votre unité au mur. Voici les instructions importantes à suivre pour garantir un montage correct :

L'unité assemblée doit être parfaitement d'équerre en termes de hauteur, de largeur et de profondeur pour fonctionner correctement.

Placez l'unité assemblée à plat contre le mur.

Fixez l'unité assemblée à l'aide de vis dans 3 montants muraux différents, en haut et en bas, pour des raisons de sécurité.

Les vis fournies sont destinées aux cloisons sèches et aux montants en bois. Si vos murs sont en maçonnerie, en béton ou dans un autre matériau, utilisez le matériel approprié pour fixer solidement votre unité au mur.

N'utilisez pas de chevilles murales pour fixer votre unité au mur.

La relocalisation n'est pas recommandée après l'assemblage.

**Page 35**

Placez votre appareil contre le mur

Il y a des encoches à l'arrière de votre appareil.

Ces encoches doivent s'adapter autour de la plinthe sur votre mur.

Si votre plinthe est plus haute ou plus épaisse que les encoches fournies sur l'unité, vous devrez retirer la plinthe, la couper pour qu'elle s'adapte des deux côtés de votre unité, puis la remettre au mur.

**Page 36**

L'unité assemblée DOIT affleurer la hauteur, la largeur et la profondeur pour fonctionner correctement

Une échelle sera nécessaire

Ne vous appuyez pas contre le dessus de l'appareil, cela pourrait provoquer un affaissement

Si nécessaire, dévissez les sous-pattes dans le sens antihoraire si nécessaire dans les 4 coins jusqu'à ce que votre appareil soit de niveau dans toutes les directions

**Page 37**

Localisez les montants dans le mur à l'aide d'un détecteur de montants. Utilisez un crayon pour marquer les emplacements des montants sur la surface supérieure du panneau arrière supérieur (G). À l'aide d'un niveau, reportez les emplacements des montants vers la traverse inférieure (K) et, avec un crayon, marquez les emplacements des montants. Vous devez localiser au moins 3 montants DIFFÉRENTS dans la direction horizontale, mais 4 seraient encore mieux. Utilisez une échelle pour accéder aux montants. Évitez de vous appuyer sur le sommet de l'unité, car cela pourrait provoquer un affaissement.

**Page 38**

Tout d'abord, assurez-vous que votre unité est toujours de niveau dans toutes les directions. Percez des trous pilotes de 3 mm (1/8") à travers le panneau arrière supérieur (G) et le longeron inférieur (K) aux emplacements des repères des montants. Fixez l'unité aux montants du mur avec les vis (3). Une échelle sera nécessaire. Ne vous appuyez pas sur le dessus de l'unité, car cela pourrait provoquer un affaissement.

**Page 39**

Les prochaines étapes consistent à assembler le cadre et le mécanisme du lit en métal. Ces pièces se trouvent dans le carton du mécanisme de lit escamotable #3678096COM.

**Page 40**

presse dans chaque trou

**Page 43**

L'extrémité "longue" des deux pistons doit être fixée ici. Les extrémités des deux pistons doivent être insérées dans la rainure du cadre de lit une fois assemblées.

**Page 44**

Déjà attaché à votre appareil

Avec une personne de chaque côté, soulevez le mécanisme du lit, alignez les trous de l'assemblage du lit avec le grand trou de douille des bras de pivot gauche et droit (20e et 20f) déjà installés sur votre unité, et insérez les broches de pivot (20k) comme montré. Fixez les axes de pivot avec un boulon de 10mm (20p).

L'armoire n'est pas illustrée pour permettre une vue dégagée de l'ensemble du cadre de lit. Ne fixez pas les pistons aux bras de pivot gauche et droit à ce stade, cela sera fait à l'étape 35.

**Page 45**

Avec une personne de chaque côté, soulevez délicatement le cadre de lit en position fermée. Pendant qu'une personne pousse le cadre du lit dans l'armoire, passé les 90 degrés, l'autre personne doit engager le piston à gaz avant (20h) de chaque côté de l'unité, à la broche avant des bras de pivot gauche et droit (20e et 20f). Ensuite, fixez fermement avec deux écrous (20r).

Pour engager le piston à gaz arrière (20h) de chaque côté de l'unité, agitez lentement et soigneusement le cadre de lit d'avant en arrière jusqu'à ce que vous puissiez insérer les pistons à gaz (20h) sur la goupille arrière des bras de pivot gauche et droit (20e & 20f). Ensuite, fixez fermement avec deux écrous (20r).

Poussez ici dans l'armoire



# Français

## Page 46

L'armoire n'est pas illustrée pour permettre une vue dégagée de l'ensemble du cadre de lit  
Tirez le cadre de lit vers le bas, puis fixez la jambe (20c) comme illustré

Le cadre de lit est équipé d'un mécanisme de verrouillage pour verrouiller la jambe (20c) en place.  
Pour verrouiller ou déverrouiller le pied, tirez sur le mécanisme de verrouillage.  
Appliquez l'étiquette d'avertissement ici

## Page 47

Bonne orientation du support  
bord brut

## Page 48

Bonne orientation du support  
bord brut

## Page 49

Rail de support

Avec l'aide d'une autre personne, soulevez l'assemblée de la porte gauche (O), positionnez les supports (13) sur les trois rails de support du cadre de lit et mettez-le en place.

Répétez la procédure pour l'assemblage de la porte de droite (P).

**IMPORTANT:**

Tout d'abord, déverrouillez et retournez le pied dans l'armoire.

Ensuite, abaissez un peu le cadre de lit pour permettre au dégagement d'accrocher les assemblages de porte (O et P).

L'armoire n'est pas illustrée pour permettre une vue dégagée de l'ensemble du cadre de lit  
Les trous dans les panneaux de porte (O et P) seront plus proches les uns des autres au centre

## Page 50

Avec l'aide d'une autre personne, ouvrez délicatement le cadre de lit

Alignez les trous du cadre de lit avec les trous des panneaux (O et P) et fixez avec les vis (11).

L'armoire n'est pas illustrée pour permettre une vue dégagée de l'ensemble du cadre de lit

## Page 51

Une échelle sera nécessaire

Ne vous appuyez pas contre le dessus de l'appareil, cela pourrait provoquer un affaissement

Fixez le rail d'arrêt (N) sur la face inférieure du dessus (C) avec les vis (11)

Appuyez sur un capuchon en plastique (20j) à chaque extrémité d'une latte en bois (20g).

Enfoncez les deux capuchons en plastique (20j), attachés à la lamelle en bois, dans les trous du cadre de lit en métal.

Répétez la procédure pour les 28 lattes de bois et 56 capuchons en plastique.

bord fini

Glissez les lattes de bois sous les sangles à chaque coin

## Page 52

cadre légèrement ouvert

L'avant de l'appareil n'est pas illustré pour permettre une vue dégagée sur le support et le bas. Pendant qu'une personne ouvre légèrement le cadre du lit et le maintient en place, insérez les boulons de connexion installés dans le support (F) dans les connecteurs du bas (D).

Tournez les connecteurs dans le sens des aiguilles d'une montre pour les verrouiller en place.

Tournez dans le sens des aiguilles d'une montre pour verrouiller en place

## Page 53

### CHARGES MAXIMALES

Ce meuble a été conçu pour supporter les charges maximales indiquées. En excédant ces limites de charge, le meuble pourrait devenir instable, s'effondrer, et/ou causer des blessures graves.

Ce lit est conçu pour accueillir un matelas full, jusqu'à 10 pouces d'épaisseur.

\* avec un poids maximum de 60 livres (27.2kg)

\* avec un poids minimum de 30 livres (13.6kg)

Après avoir fini d'assembler votre lit escamotable, veuillez conserver le manuel de montage en le plaçant sous le matelas, dans le cadre de la partie mobile du lit.

Une fois que vous avez placé votre drap housse sur votre matelas, fixez votre matelas avec les sangles fournies dans les 4 coins du cadre de lit.

Gardez le lit fermé lorsqu'il n'est pas utilisé.

Il est recommandé de ne pas laisser les oreillers et / ou oreillers décoratifs en place lorsque le lit est fermé pour préserver le mécanisme.

Plus le poids du matelas

## Page 54

Enregistrez votre produit pour recevoir les éléments suivantes:

\* Détails sur les nouvelles tendances - un aperçu sur les nouveautés

\* Sondages - avoir une voix au sein de notre communauté

\* Offres exclusives et codes promo

\* Service de pièces de rechange rapide et facile

Pour enregistrer votre produit, visitez [ameriwoodhome.com](http://ameriwoodhome.com)

5 Étoiles

Visitez le site Web de votre détaillant local, évaluez votre produit acheté et laissez-nous quelques commentaires !

Merci