

# 2498013COM Bookcase Room Divider

**systembuild**<sup>™</sup>  
EVOLUTION

Date of Purchase \_\_\_ / \_\_\_ / \_\_\_  
Lot Number:

B342498013COM01DM

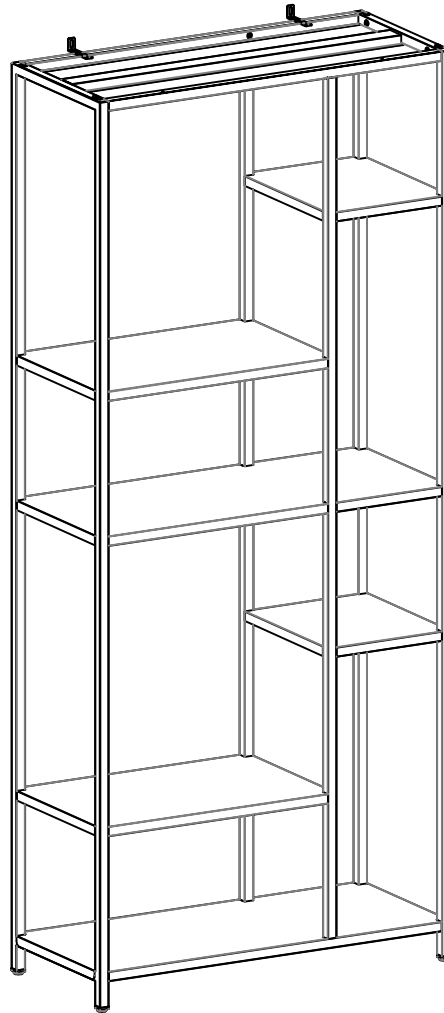

**THIS INSTRUCTION BOOKLET CONTAINS IMPORTANT SAFETY INFORMATION. PLEASE READ AND KEEP FOR FUTURE REFERENCE.**

**Do Not Return This Product!**

Contact our customer service team for help first.

Call: 1-800-489-3351 (toll free)

Visit: [www.ameriwoodhome.com](http://www.ameriwoodhome.com)



## WARNING

- Unit can tip over causing severe injury or death.
- Anchor unit to stud in wall (if instructed to).
- Do Not allow children to climb on unit.
- Put heavy items on lower shelves or drawers.



Follow Ameriwood Home



# Contact Us!

## Do NOT return this product!

Contact our friendly customer service team first for help.



Visit [ameriwoodhome.com](http://ameriwoodhome.com)

Assembly Tips



# Helpful Hints

PEOPLE NEEDED FOR ASSEMBLY: 1-2

ESTIMATED ASSEMBLY TIME: 1 HOUR

- Open your item in the area you plan to keep it to avoid excessive heavy lifting.
- Identify, sort and count the parts before attempting assembly.
- Back panel must be used to make sure your unit is sturdy.
- Do NOT use harsh chemicals or abrasive cleaners on this item.
- Never push, pull, or drag your furniture.



# Before You Start

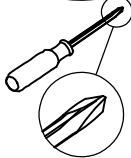
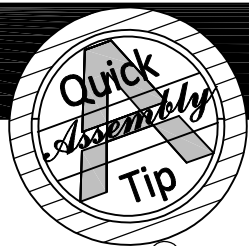

- ✓ Read through each step carefully and follow the proper order
- ✓ Separate and count all your parts and hardware
- ✓ Give yourself enough room for the assembly process
- ✓ Have the following tools: Flat Head Screwdriver, #2 Phillips Head Screwdriver and Hammer
- ✓ Caution: If using a power drill or power screwdriver for screwing, please be aware to slow down and stop when screw is tight. Failure to do so may result in stripping the screw.

# Board Identification

Not actual size

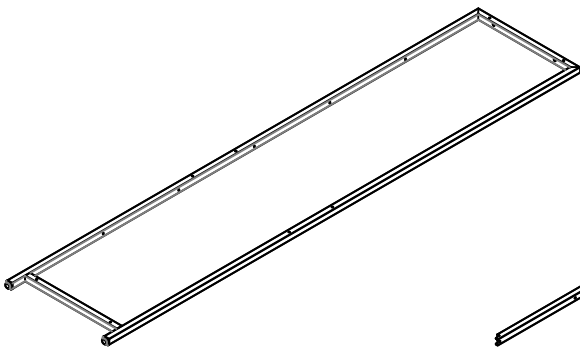

**A**  
SIDE FRAME  
Qty:2

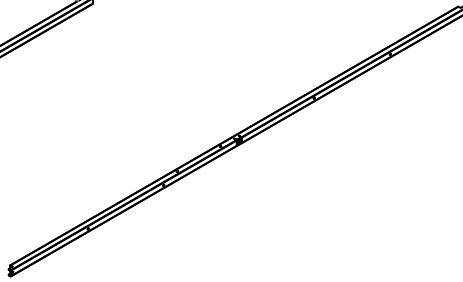

**B**  
RAIL  
Qty:2

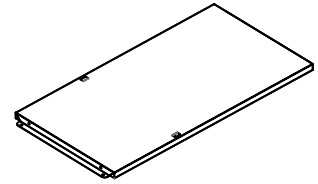

**C**  
TOP

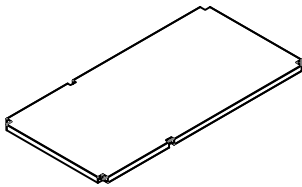

**D**  
BOTTOM

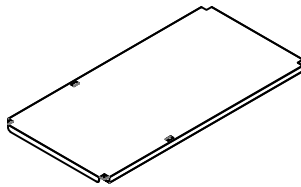

**E**  
FIXED SHELF

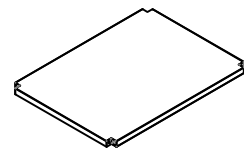

**F**  
LEFT SHELF  
Qty:2

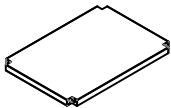

**G**  
RIGHT SHELF  
Qty:2

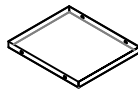

**H**  
BACK PANEL

# Board Identification

Not actual size

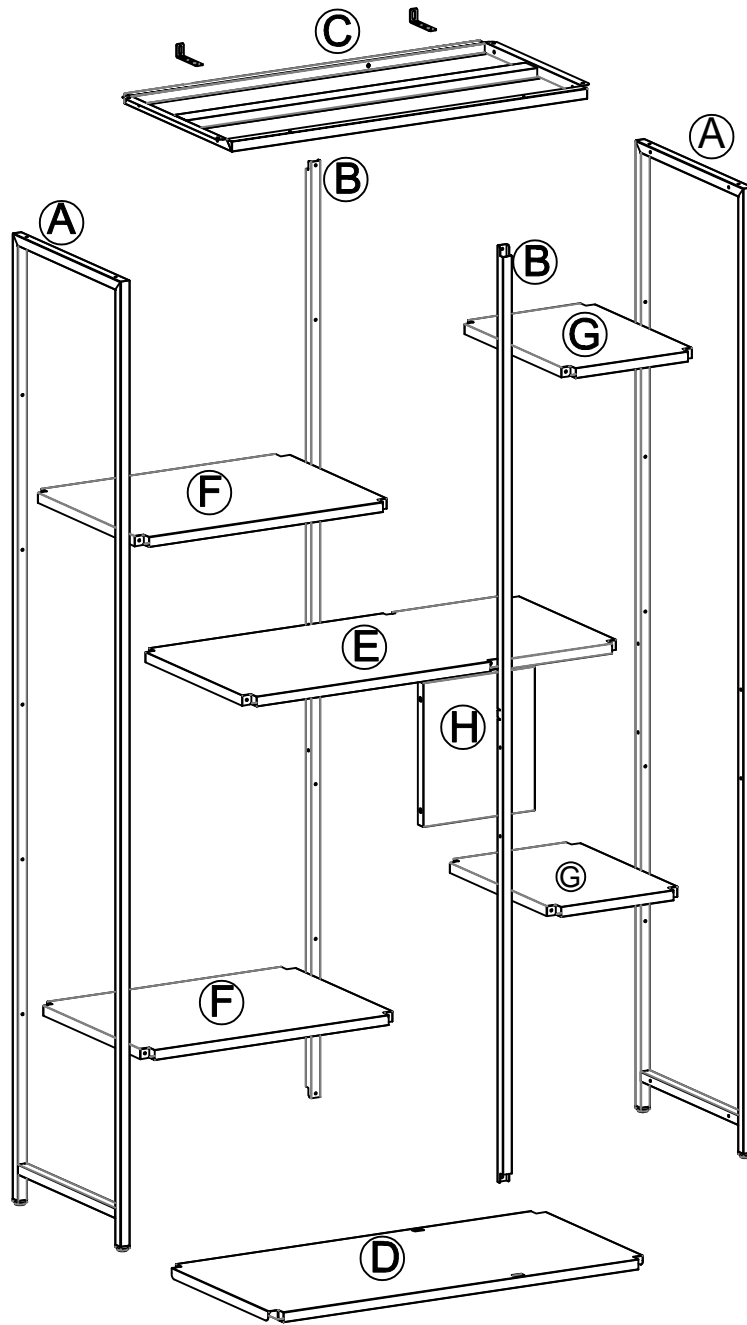

Hardware Bag Reference number:  
22498013COM0DM

**systembuild**<sup>™</sup>  
EVOLUTION

# Part List

Actual Size

For any replacement hardware,  
order part # 22498013COM0DM

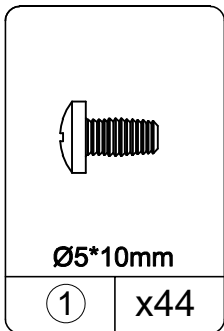

SCREW  
TDM0067  
spare: 2

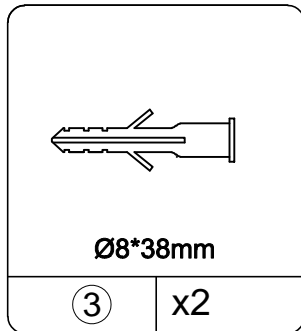

WALL ANCHOR  
TDM0009

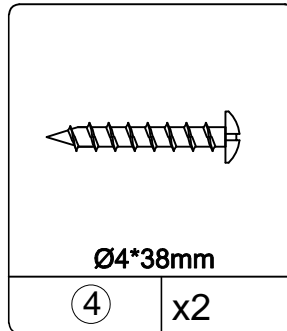

SCREW  
TDM0010

---

Not Actual Size

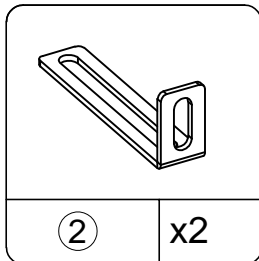

WALL BRACKET  
TDM0068

# STEP 1

- Attach (A) to (D) as below shown.

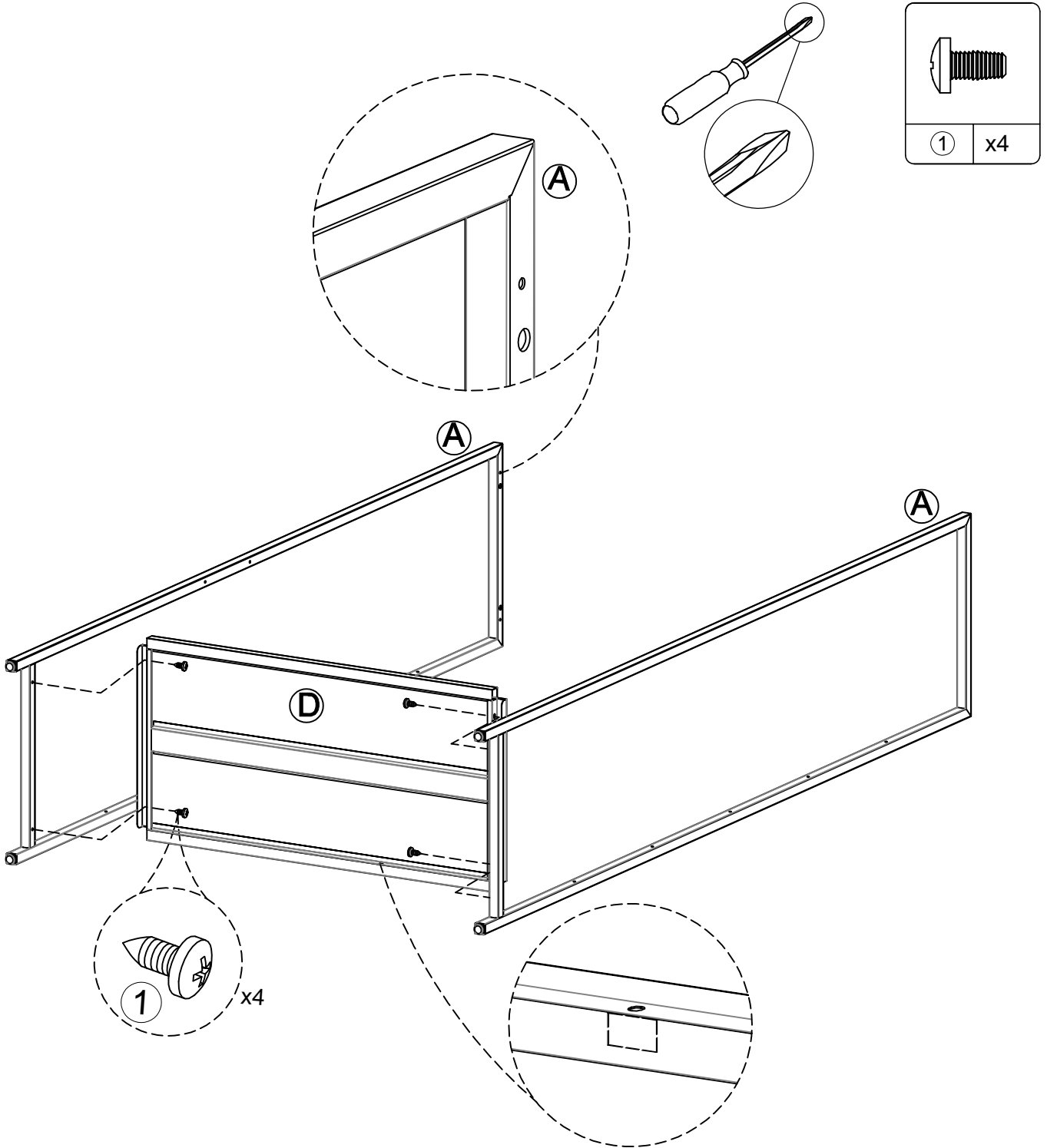

# STEP 2

- Attach (E) to (A) as below shown.

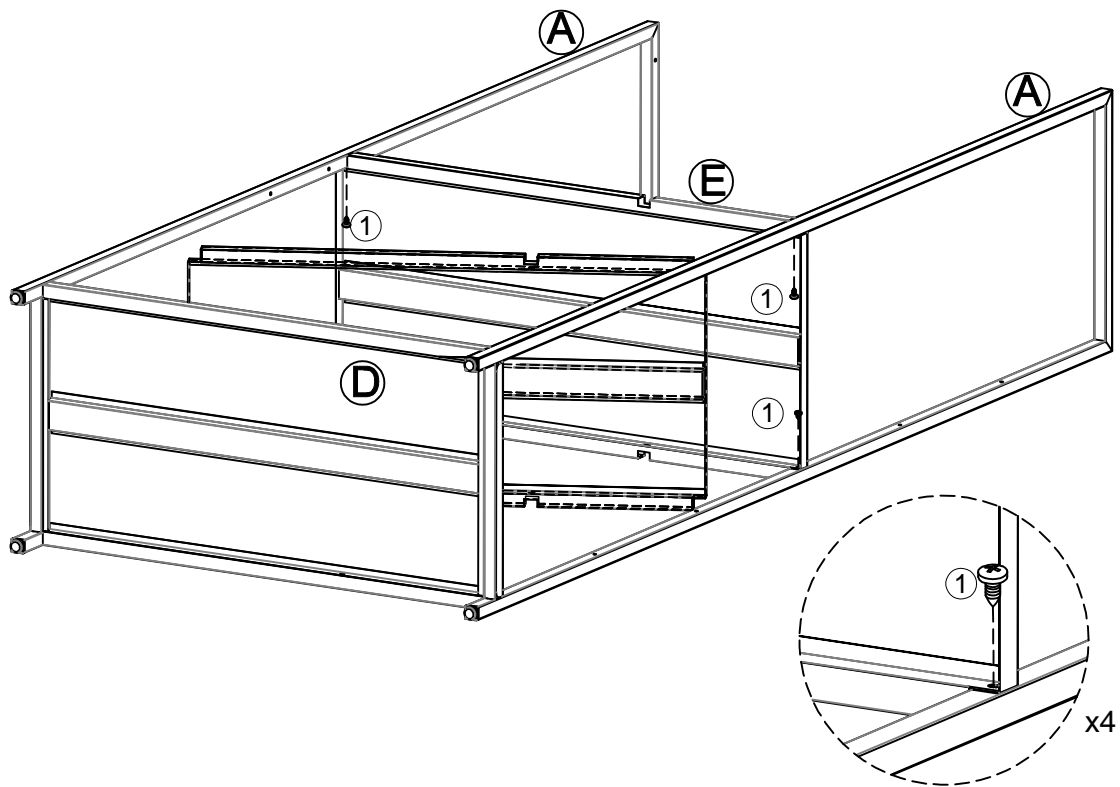
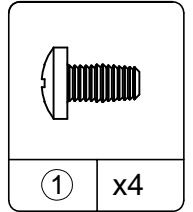
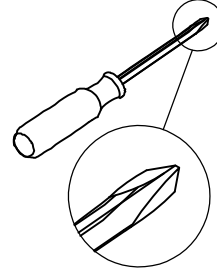

# STEP 3

- Attach (B) to (D) & (E) as below shown.

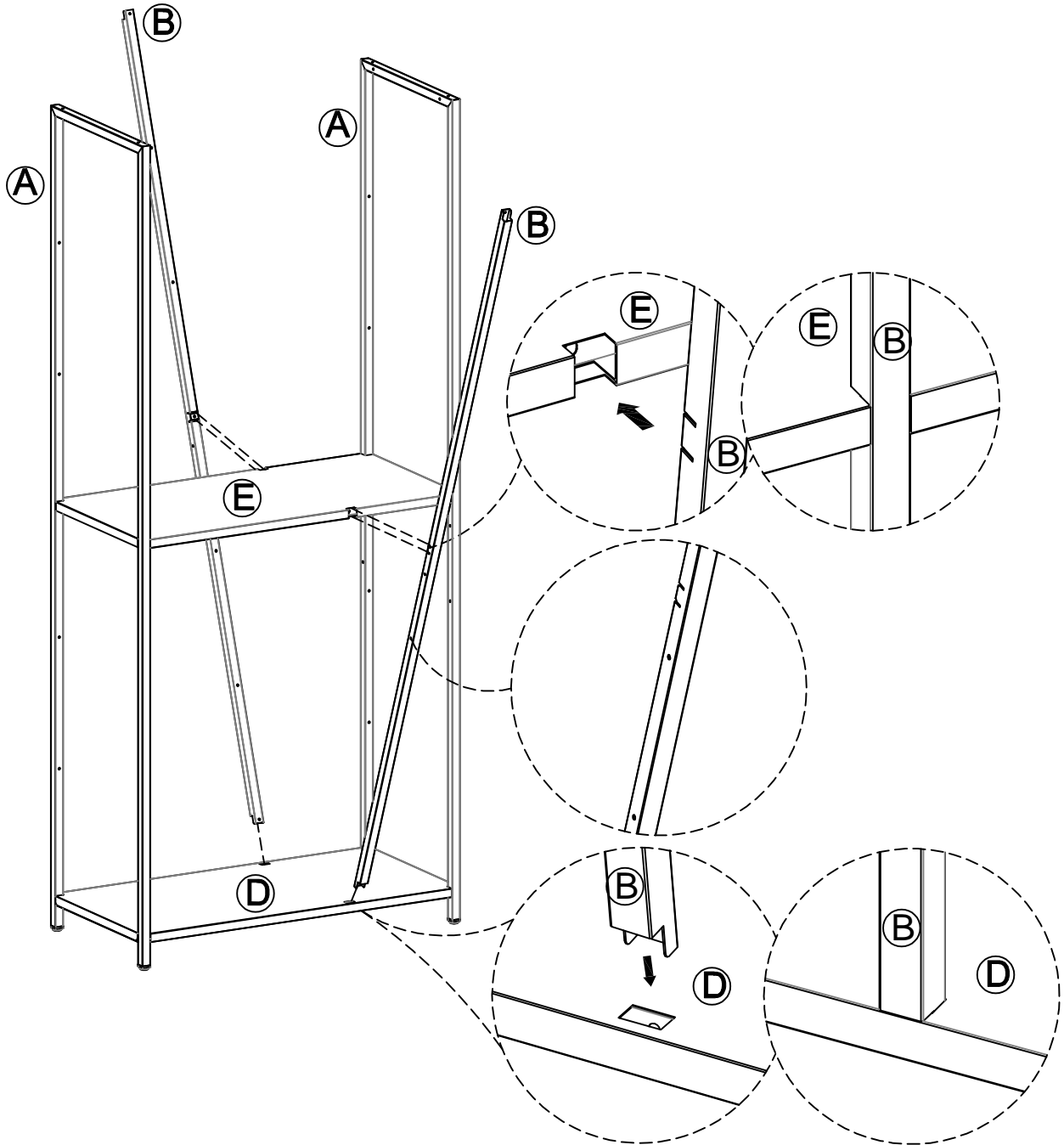



# STEP 4

- Attach (B) to (D) & (E) as below shown.

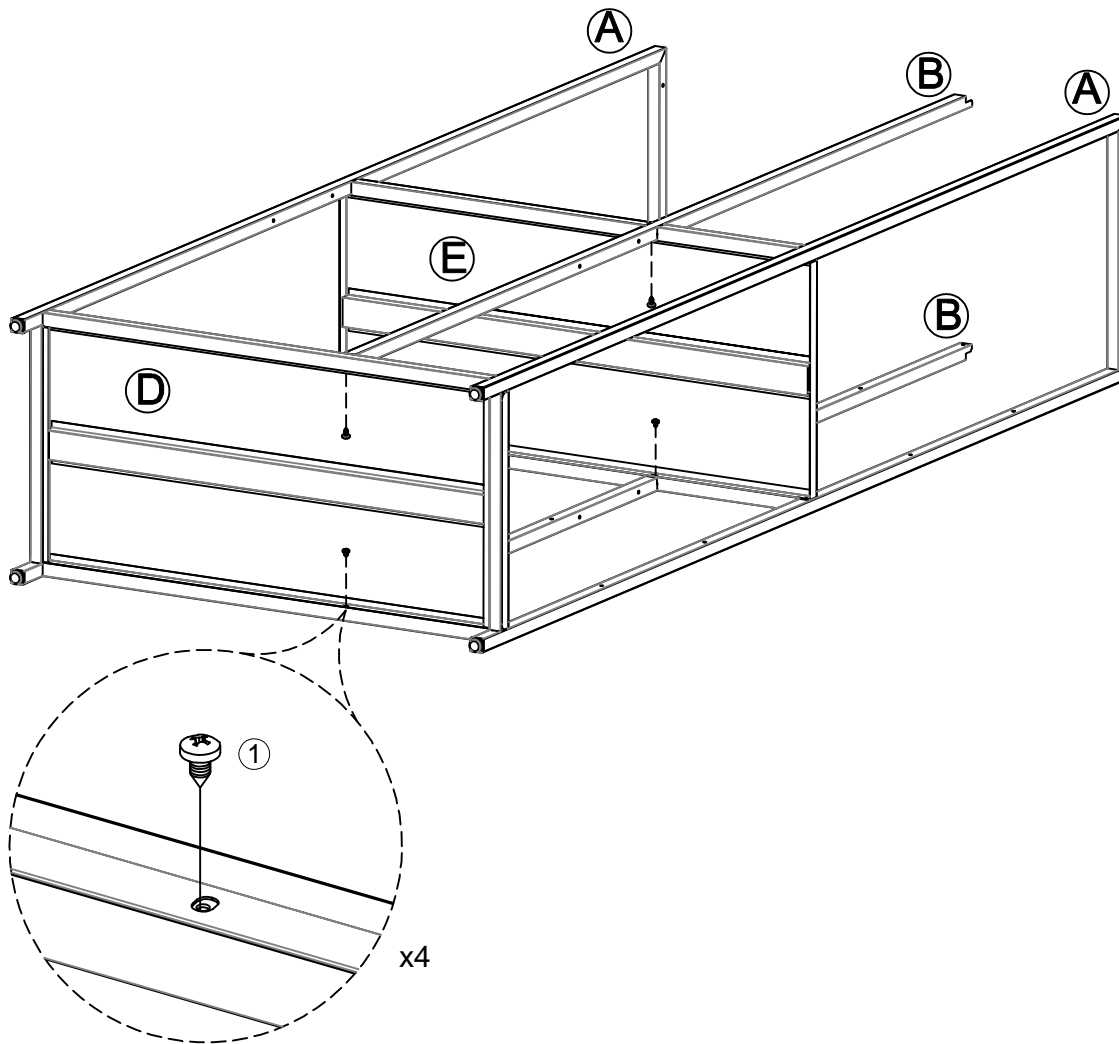
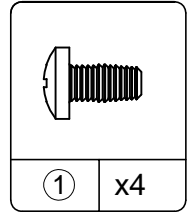
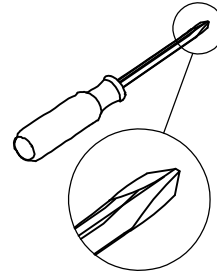

# STEP 5

If you want to attach this unit to the wall on its side, please go to step 10 to step 14.

- Attach (2) to (C) as below shown.
- Attach (C) to (A) & (B) as below shown.

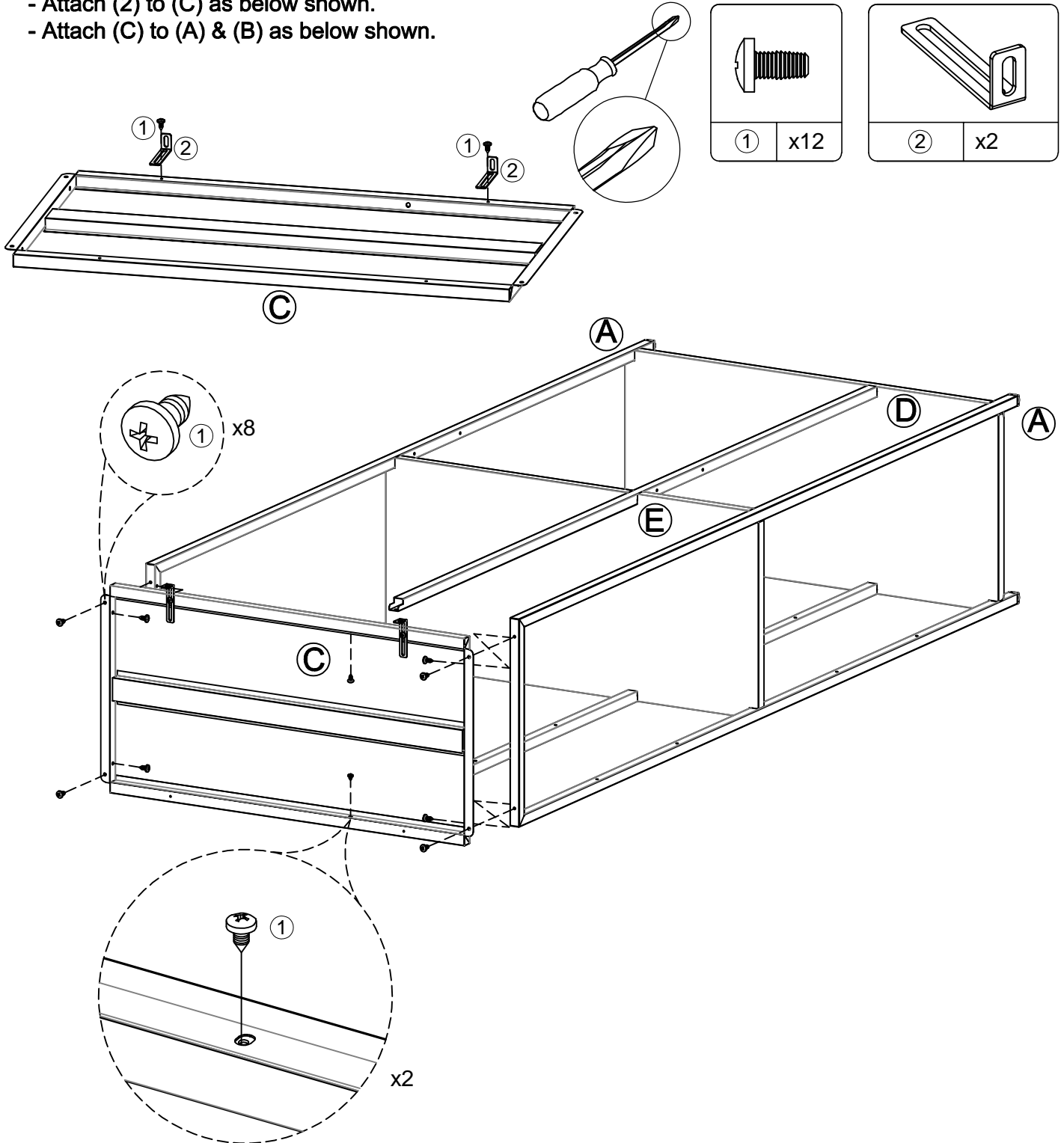

# STEP 6

- Attach (F) & (G) to (A) & (B) as below shown.

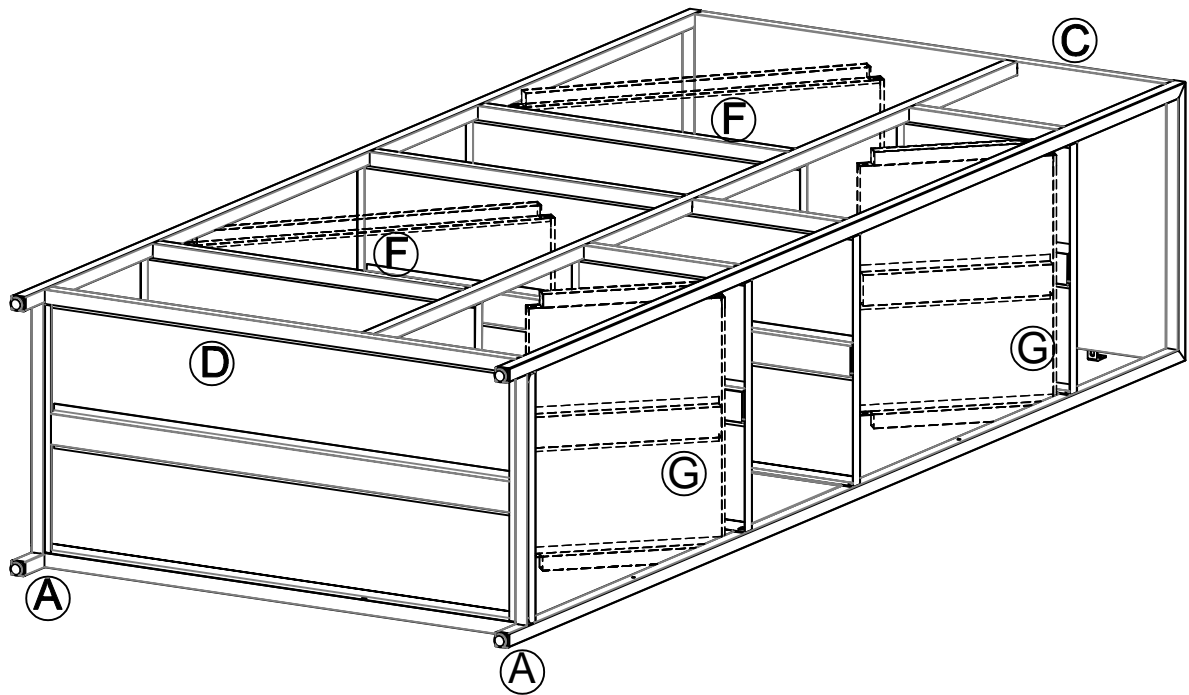

# STEP 7

- Attach (F) & (G) to (A) & (B) as below shown.

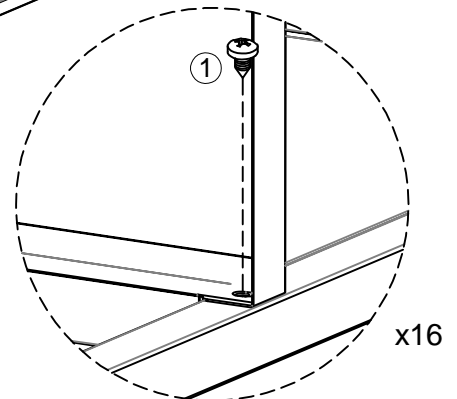
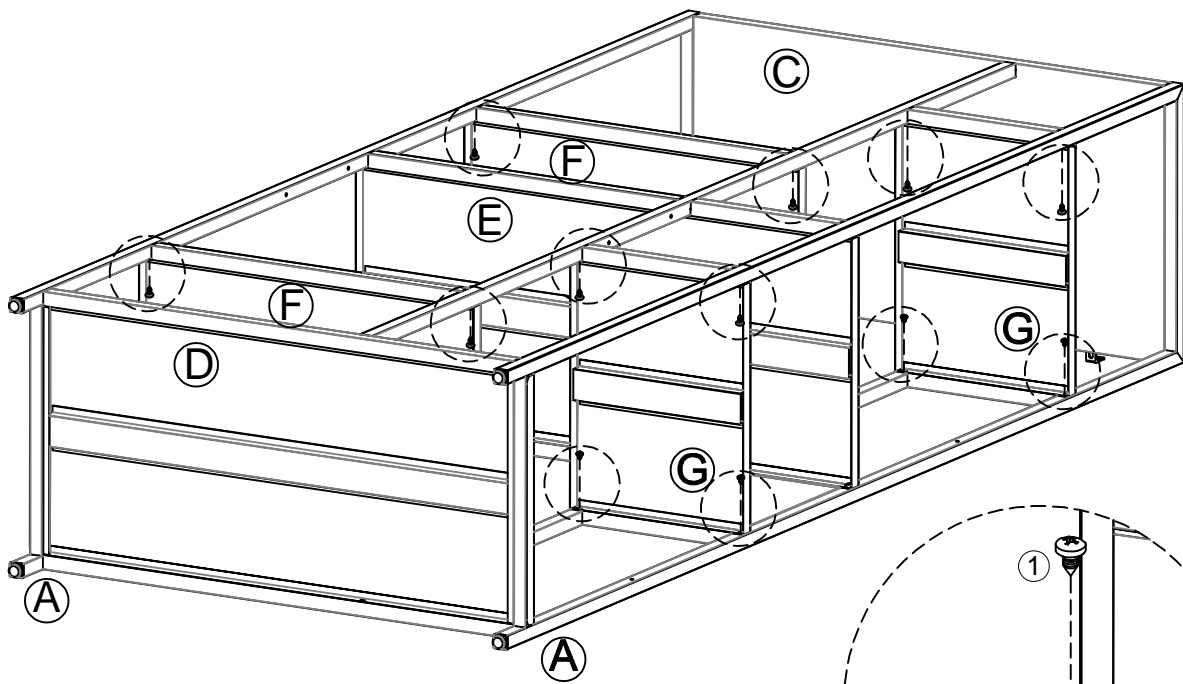
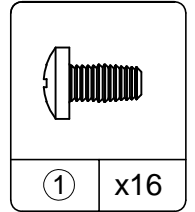
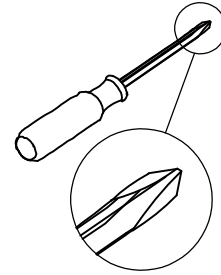

# STEP 8

- Attach (H) to (A) & (B) as below shown.

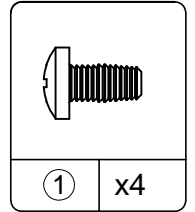
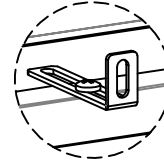
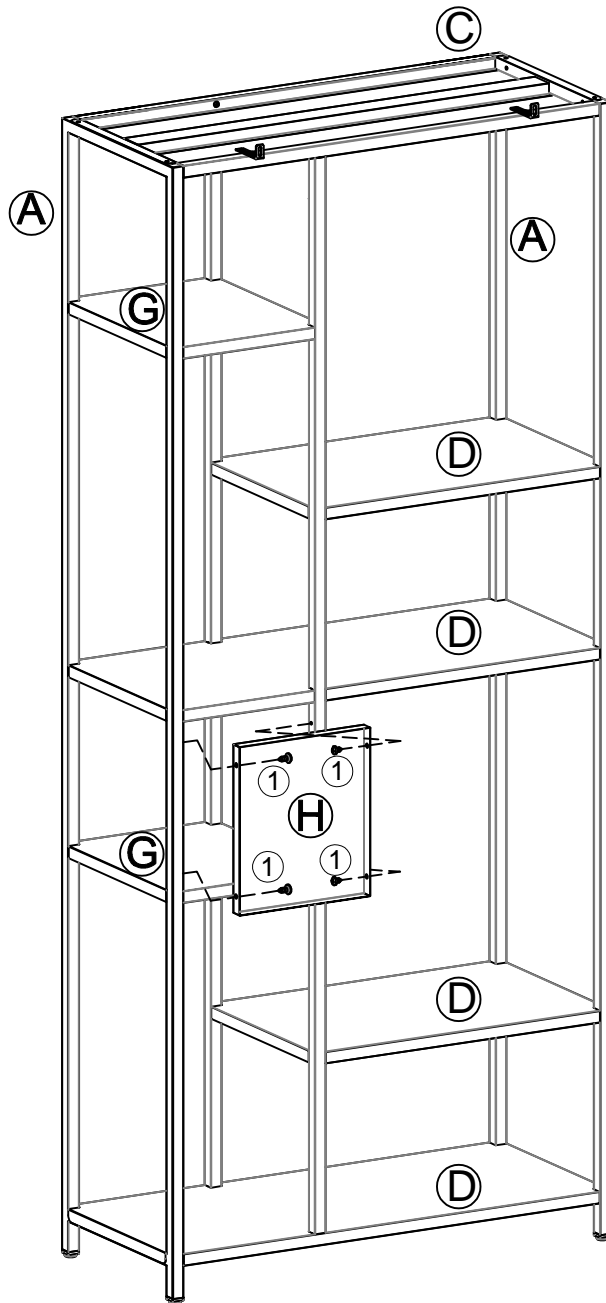
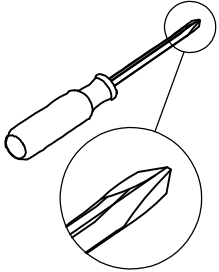

# STEP 9

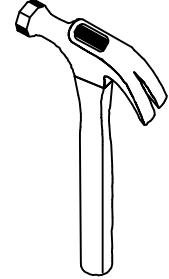
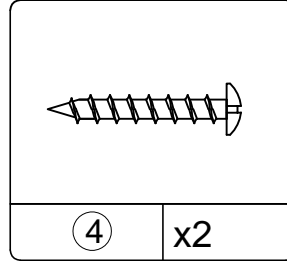
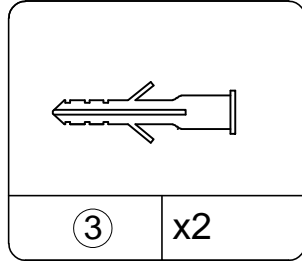
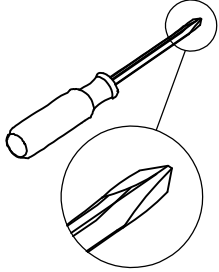

**IMPORTANT:** THIS UNIT MUST BE SECURE TO THE WALL TO HELP PREVENT TIPOVER. FOLLOW THESE INSTRUCTIONS TO INSTALL THE ANTI-TIPPING SAFETY BRACKET PROVIDED WITH THIS PRODUCT.

**OPTION 1: Attachment into a wall stud (preferred method)**

Using a stud finder, locate a stud in the wall. Place your unit against the wall aligned in this location. To make driving the screw easier, you can drill a 1/8" diameter pilot hole (3mm) into the stud. Drive the screw (4) through the hole of back panel into the wall stud.

**OPTION 2: Attachment into drywall**

Locate your unit where desired against a wall then move your unit aside. Drill a 3/16" diameter hole (5mm) into the wallboard. Tap the wall anchor (3) into the hole until it is flush. Move your unit into location and fasten it to the wall anchor (3) with the screw (4).

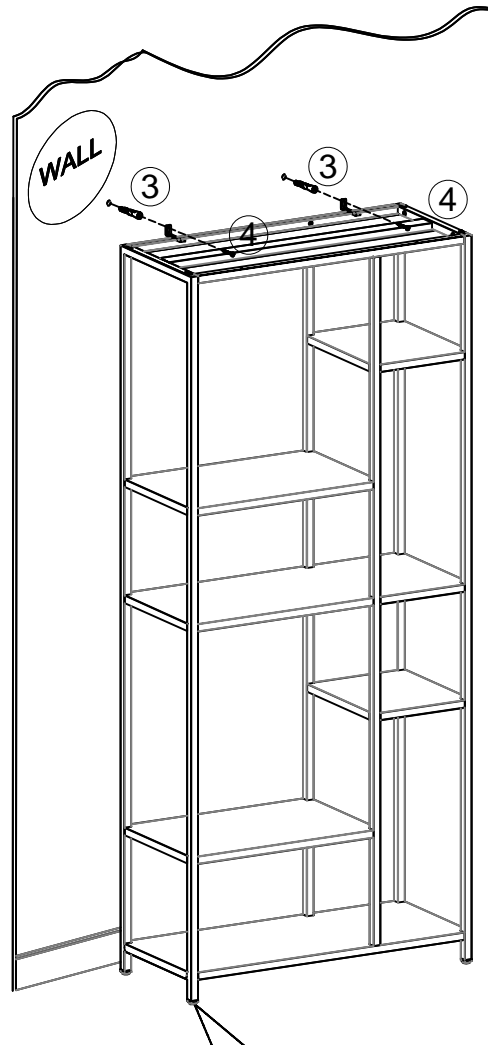

**WARNING**

**Serious or fatal crushing injuries can occur from furniture tipover. To prevent tipover:**

- \* Install tipover restraint provided
- \* place heaviest items in the lowest shelves
- \* Unless specifically designed to accommodate, do not set TVs or other heavy objects on the top of this product
- \* Never allow children to climb or hang on drawers, door, or shelves

**Use of tipover restraints may only reduce, but not eliminate the risk of tipover**

If the ground is uneven, adjust the foot levelers by rotating them to your preferred height. Once the unit is standing and the levelers are adjusted, make sure the unit does not wobble

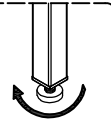

**For Masonry, Concrete, or other wall materials:** Consult your local hardware store for appropriate anchors to securely attach the safety bracket.

# STEP 10

This step is for attaching this unit to the wall on its left side.

- Attach (2) to (C) as below shown.
- Attach (C) to (A) & (B) as below shown.

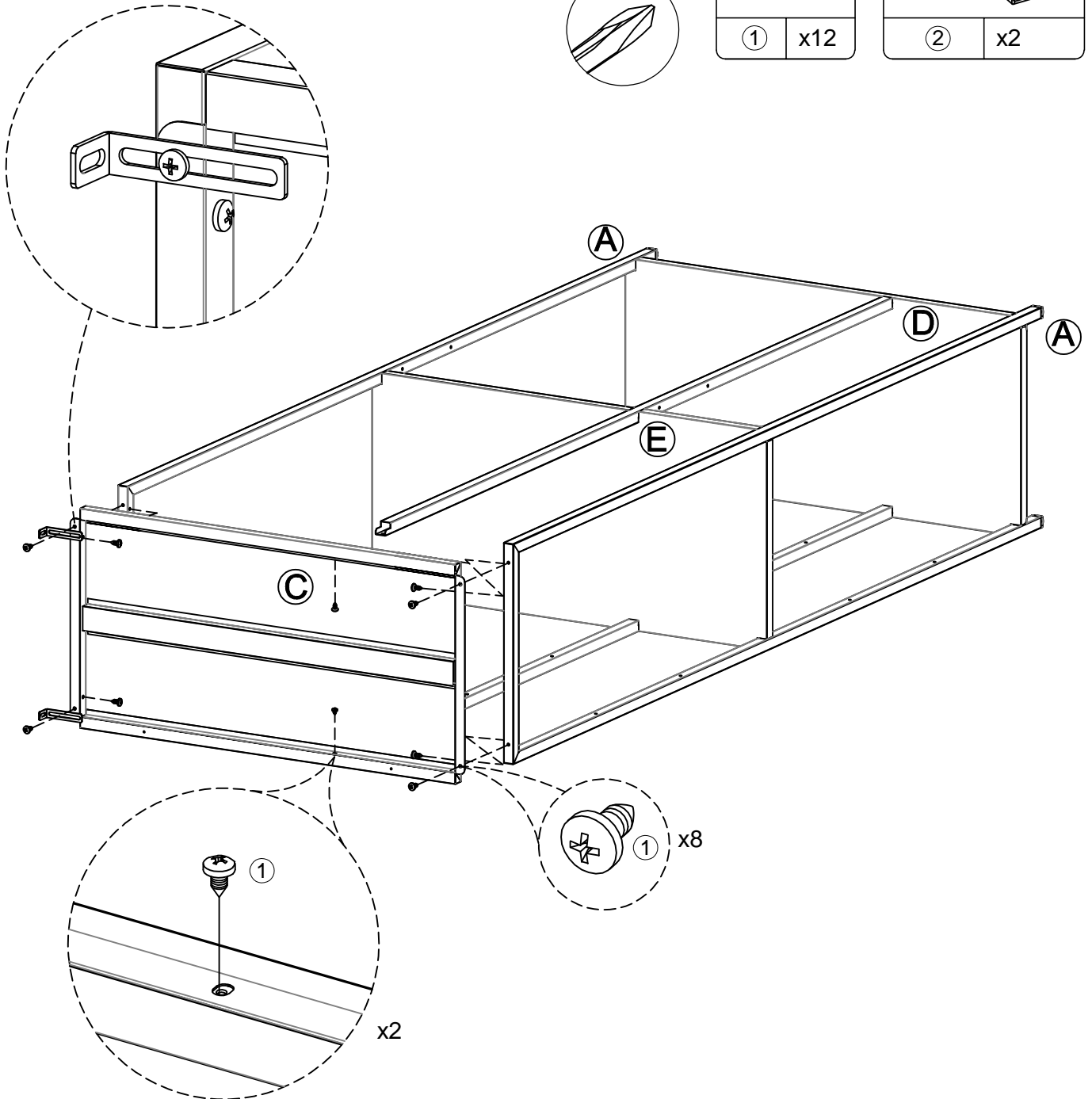
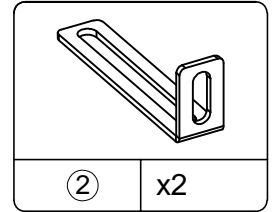
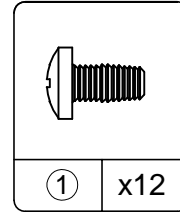
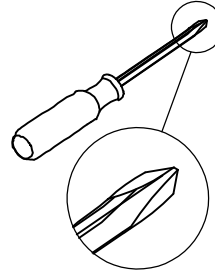

# STEP 11

This step is for attaching this unit to the wall on its left side.  
- Attach (F) & (G) to (A) & (B) as below shown.

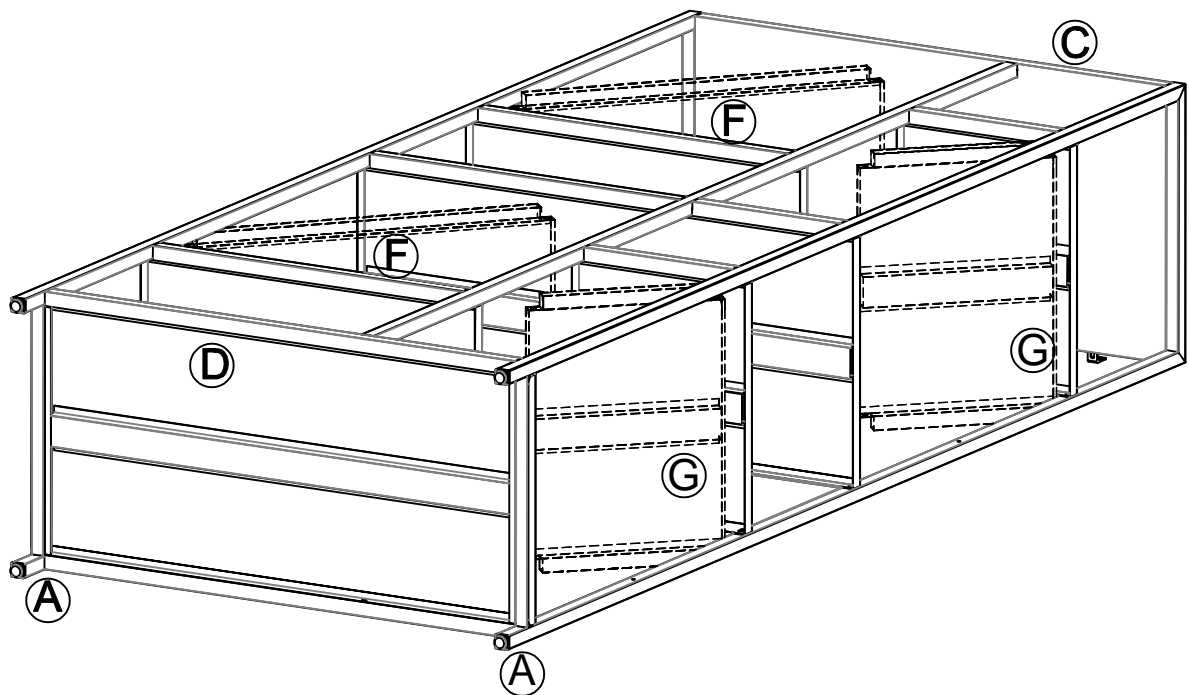



# STEP 12

This step is for attaching this unit to the wall on its left side.  
- Attach (F) & (G) to (A) & (B) as below shown.

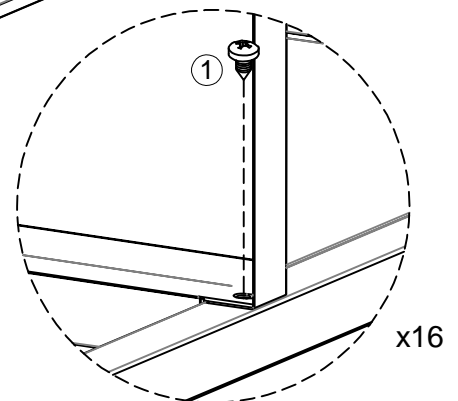
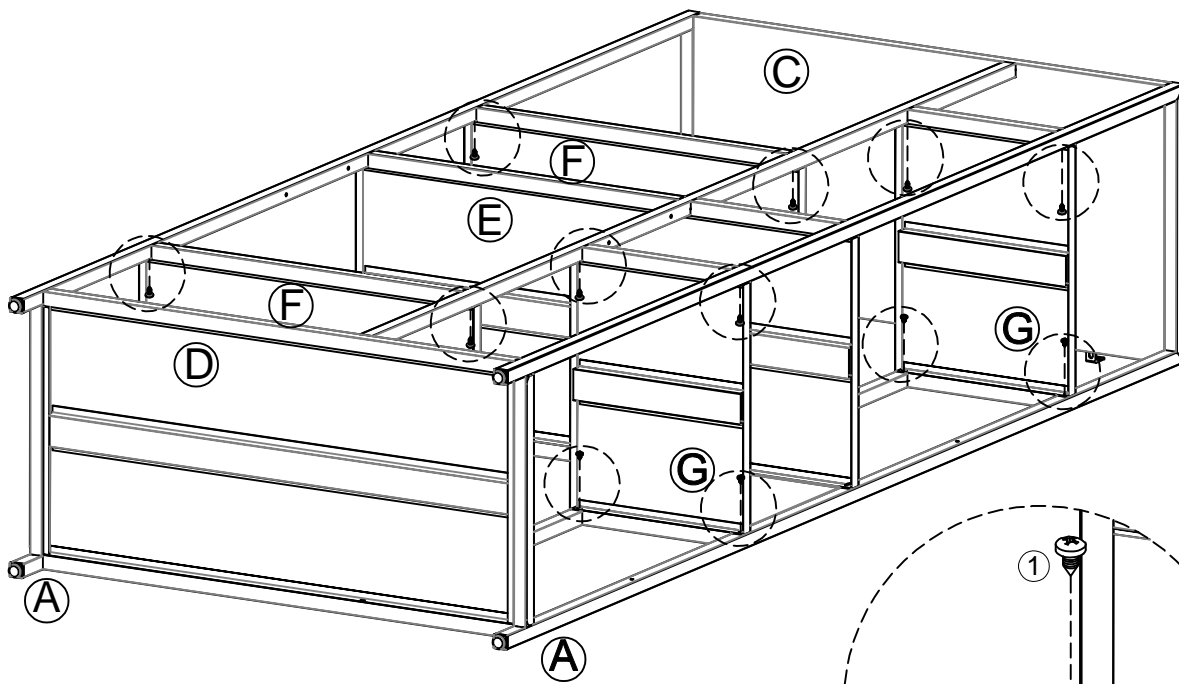
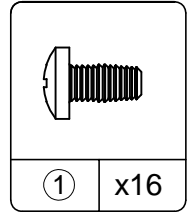
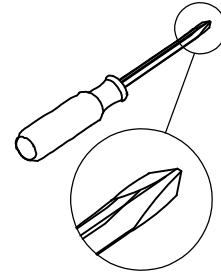

# STEP 13

This step is for attaching this unit to the wall on its left side.  
- Attach (H) to (A) & (B) as below shown.

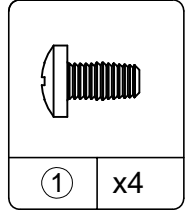
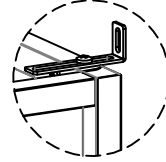
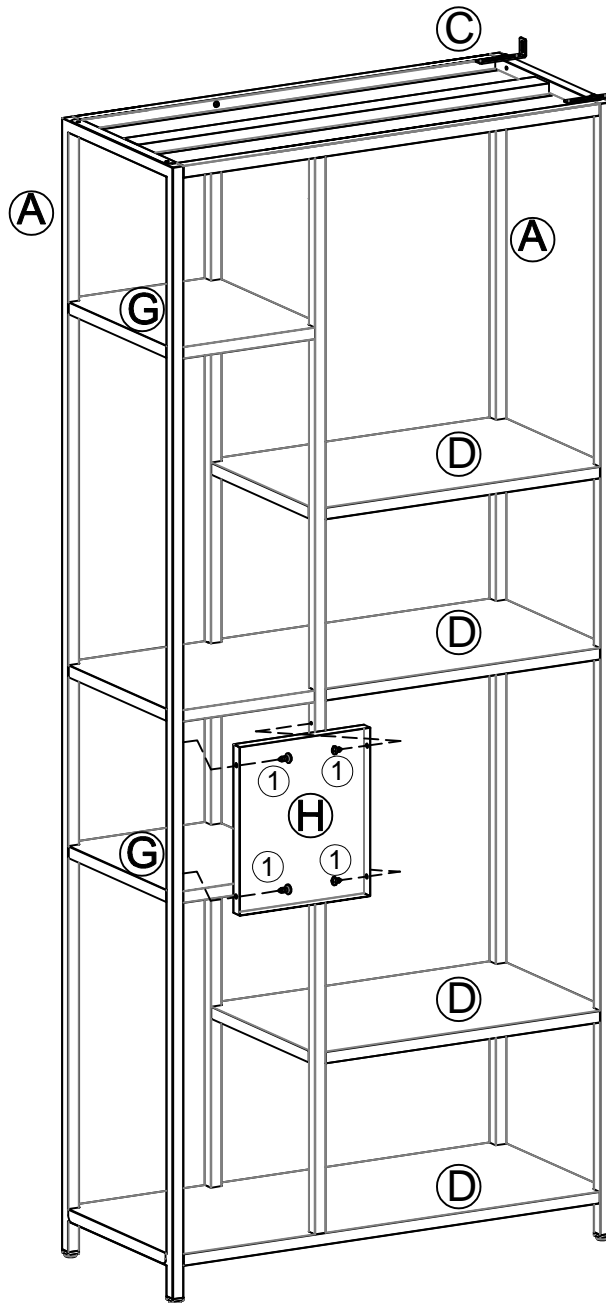
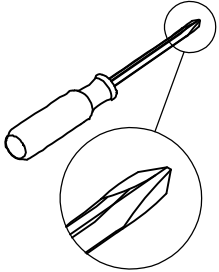

# STEP 14

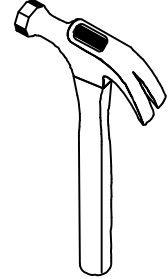
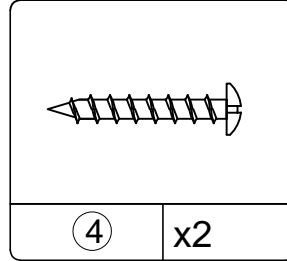
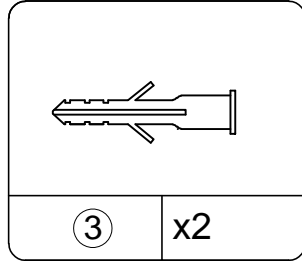
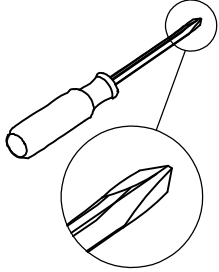

**IMPORTANT:** THIS UNIT MUST BE SECURE TO THE WALL TO HELP PREVENT TIPOVER. FOLLOW THESE INSTRUCTIONS TO INSTALL THE ANTI-TIPPING SAFETY BRACKET PROVIDED WITH THIS PRODUCT.

**OPTION 1: Attachment into a wall stud (preferred method)**

Using a stud finder, locate a stud in the wall. Place your unit against the wall aligned in this location. To make driving the screw easier, you can drill a 1/8" diameter pilot hole (3mm) into the stud. Drive the screw (4) through the hole of back panel into the wall stud.

**OPTION 2: Attachment into drywall**

Locate your unit where desired against a wall then move your unit aside. Drill a 3/16" diameter hole (5mm) into the wallboard. Tap the wall anchor (3) into the hole until it is flush. Move your unit into location and fasten it to the wall anchor (3) with the screw (4).

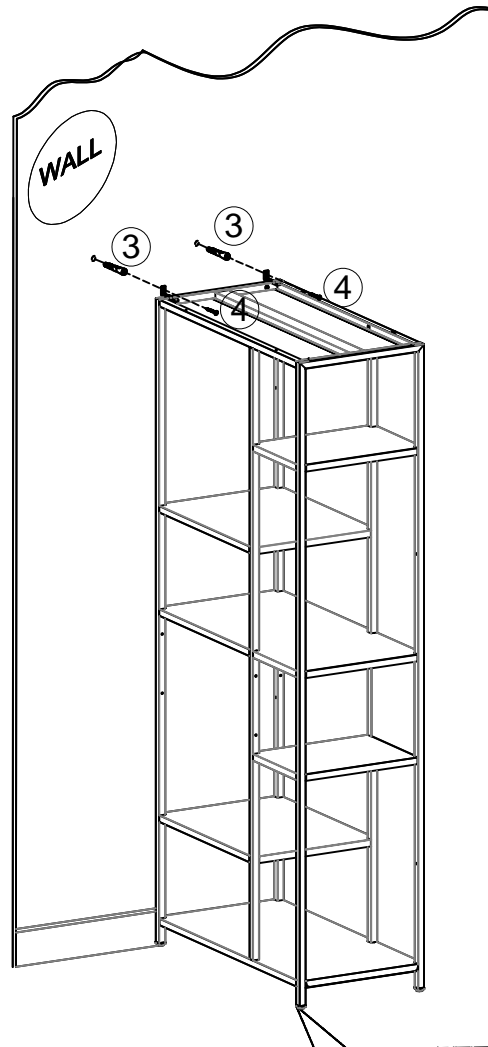

## WARNING

**Serious or fatal crushing injuries can occur from furniture tipover.**

**To prevent tipover:**

- \* Install tipover restraint provided
- \* place heaviest items in the lowest shelves
- \* Unless specifically designed to accommodate, do not set TVs or other heavy objects on the top of this product
- \* Never allow children to climb or hang on drawers, door, or shelves

**Use of tipover restraints may only reduce, but not eliminate the risk of tipover**

If the ground is uneven, adjust the foot levelers by rotating them to your preferred height. Once the unit is standing and the levelers are adjusted, make sure the unit does not wobble

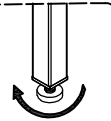

**For Masonry, Concrete, or other wall materials:** Consult your local hardware store for appropriate anchors to securely attach the safety bracket.

# Maximum Loads

This unit has been designed to support the maximum loads shown. Exceeding these load limits could cause sagging, instability, product collapse, and/or serious injury.

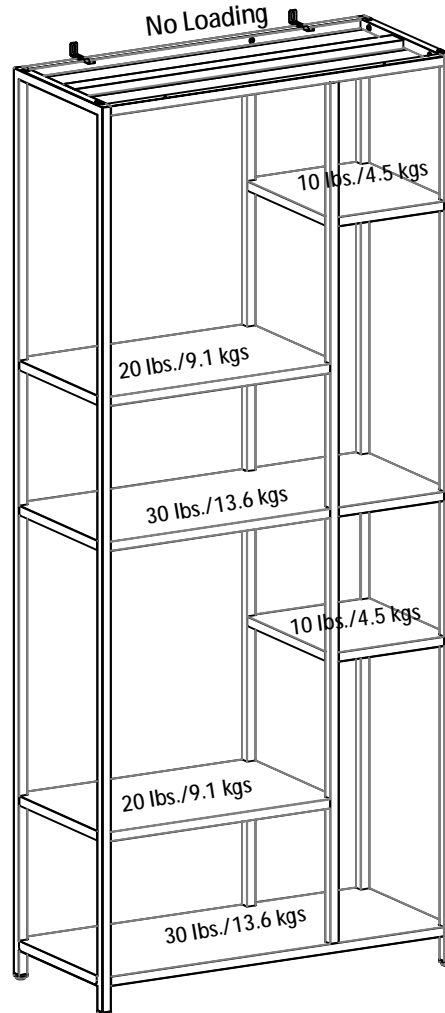

**Warning:** Risk of injury to persons - do not place a television on this furniture. This furniture is not approved for use with a television.

## Certificate of Conformity

1. This certificate applies to the Dorel Home Furnishings, Inc. product identified by this instruction manual.
2. This certificate applies to compliance of this product with the CPSC Ban on Lead-Containing Paint (16 CFR 1303).
3. This product is distributed by: Dorel Home Furnishings, Inc.  
410 East First Street South  
Wright City, MO 63390  
636-745-3351
4. Site of Manufacture: Henan China
5. See front page of instruction manual for date of manufacture.

---

Register your product to receive the following:



- \* New trend details - sneak peek on what's new
- \* Surveys - have a voice within our community
- \* Exclusive deals and discount codes
- \* Quick and easy replacement part service

To register your product, visit [ameriwoodhome.com](http://ameriwoodhome.com)

## *5 Star Rating*



Visit your local retailer's website, rate your purchased product and leave us some feedback!

We would like to extend a big "Thank You" to all of our customers for taking the time to assemble this Ameriwood Home product, and to give us your valuable feedback.

*Thank  
You!*

## Cubierta Delantera

Este libro de instrucciones contiene información **IMPORTANTE** de seguridad. Por favor lea y manténgalo para referencia en el futuro.

**No Regrese este producto!** Comuníquese con nuestro amigoso equipo de servicio al cliente para obtener ayuda.

Llámenos al: 1-800-489-3351 (Gratis)

Visitar: [www.ameriwoodhome.com](http://www.ameriwoodhome.com)

## PRECAUCION

Este mueble puede volcarse y causar graves heridas y/o muerte.

Anclar el mueble a un poste de madera en la pared (si esto se requiere).

No Permita que los niños monten el mueble.

Mantenga los artículos más pesados en los cajones de abajo.

## Consejos Útiles (página 2)

- Abra su artículo en el área donde usted planea utilizarlo para evitar levantar y moverlo menos
- Identificar, ordenar y contar las piezas antes de intentar ensamblar
- El panel de atrás debe utilizarse para asegurarse de que la unidad quede fija y firme
- No use químicas fuertes ni limpiadores abrasivos en este artículo
- Nunca empuje, tire ni arrastre los muebles

## Antes de Que Empieces (página 2)

-Lea cuidadosamente cada paso y siga el orden correcto

-Separar y contar todas sus piezas y hardware

-Dése suficiente espacio para el proceso de ensamble

-Tenga las siguientes herramientas: destornillador de cabeza plana, #2 cabeza Phillips

Destornillador y martillo

-Precaución: Si usa un taladro electrónico o un destornillador eléctrico para atornillar, por favor asegúrese que deje de atornillar cuando el tornillo este apretado. Fallar hacer esto puede causar barrer el tornillo.

## Identificación de los Paneles (Página 3)

Este no es el tamaño real

- (A) Marco izquierdo
- (B) Marco lateral derecho
- (C) Riel
- (D) Panel superior
- (E) Repisa fija
- (F) Base
- (G) Repisa izquierda
- (H) Repisa derecha
- (I) Panel trasero superior
- (J) Panel trasero inferior

## Número de referencia de la bolsa de herrajes:

**22498013COM0DM**

## Lista de Piezas (Página 5)

Tamaño real

- (1) Tornillo
- (3) Ancla de pared
- (4) Tornillo

Este no es el tamaño real

- (2) Soporte para la pared

### Página 6

Ate (F) a (A) & (B) como se muestra abajo.

### Página 7

Ate (E) a (A) & (B) como se muestra abajo.

### Página 8

Ate (C) a (E) & (F) como se muestra abajo.

### Página 9

Ate (C) a (E) & (F) como se muestra abajo.

### Página 10 & 15

Ate (2) a (C) como se muestra abajo.

Ate (C) a (A) & (B) como se muestra abajo.

### Página 11 & 16

Ate (F) & (G) a (A) & (B) como se muestra abajo.

### Página 12 & 17

Ate (F) & (G) a (A) & (B) como se muestra abajo.

### Página 13 & 18

Ate (H) a (A) & (B) como se muestra abajo.

Página 14 & 19

**IMPORTANTE: ESTA UNIDAD DEBE SER SEGURO A LA PARED PARA PREVENIR VUELCO. SIGA ESTAS INSTRUCCIONES PARA INSTALAR EL SOPORTE DE SEGURIDAD ANTIVUELCO SUMINISTRADO CON ESTE PRODUCTO.**

## **ADVERTENCIA**

**Graves lesiones por aplastamiento o muerte, pueden ocurrir desde muebles vuelco.**

**Para evitar un vuelco:**

- \* Instale el asiento proporcionan un vuelco
- \* Coloque los artículos más pesados en los cajones más bajos
- \* A menos que específicamente diseñado para acomodar, no establezca televisores u otros objetos pesados en la parte superior de este producto
- \* No permita que los niños se suban o se cuelguen de cajones, puertas o estantes
- \* No abra más de un cajón a la vez

**El uso de restarints vuelco sólo se puede reducir, pero no eliminar el riesgo de vuelco**

**OPCIÓN 1: Datos adjuntos en un poste de la pared (método preferido)**

El uso de un detector de vigas, localice un Studin la pared. Coloque la unidad contra la pared, con el soporte alineados en esta ubicación.

Para hacer la conducción más fácil el tornillo, se puede perforar un agujero piloto de 1/8 "de diámetro (3 mm) a través del soporte en el pie derecho.

Conducir el tornillo (10) a en el poste de la pared.

**OPCIÓN 2: Datos adjuntos en paneles de yeso**

Localizar su unidad en la posición deseada contra una pared y marque la pared a través del soporte de, a continuación, pasar a un lado de la unidad.

Perforar un agujero de 3/16 "de diámetro (5 mm) en el panel de yeso. Toque en el anclaje en el agujero hasta que quede al ras.

Moverle unidad en lugar y fije el soporte de pared (9) para el anclaje con el tornillo (10).

Para mampostería, hormigón u otros materiales de la pared:

Consulte a su ferretería local para los anclajes apropiados para fijar firmemente el soporte de seguridad.



## **Página 20**

### **CARGA MAXIMA**

Esta unidad ha sido diseñada para soportar la carga máxima anotada. El exceder estos límites puede causar inestabilidad, colapsarse y/o causar serias lesiones.

**ADVERTENCIA:** Riesgo de lesiones a las personas - no coloque un televisor sobre muebles. Este mueble no está aprobado para su uso con un televisor.

## **Página 21**

Registre su producto para recibir lo siguiente:

- \* Detalles de nuevas tendencias - Vistazo a lo nuevo
- \* Encuestas - alec su voz entre su comunidad
- \* Códigos de ofertas y descuentos exclusivos
- \* Fácil y rápido servicio de partes de remplace

Para registrar su producto, visite [ameriwoodhome.com](http://ameriwoodhome.com)

Clasificación de 5 estrellas

Visite el sitio web de su tienda local, califique su comprado y denos sus comentarios!

Nos gustaría enviar un gran "Agradecimiento" a todos nuestros clientes por tomarse el tiempo de ensamblar este producto de Ameriwood Home, y por darnos sus valiosos comentarios.

Gracias

## Couverture Avant

CE LIVRET D'INSTRUCTION CONTIENT DES INFORMATIONS IMPORTANTES SUR LA SÉCURITÉ. VEUILLEZ LIRE ET GARDER POUR UNE RÉFÉRENCE FUTURE

**Ne retournez pas ce produit!** Contactez notre équipe de service à la clientèle amicale d'abord pour obtenir de l'aide.

**Appelez-nous:** 1-866-452-4081 (sans frais)

**Visitez:** [www.systembuild.com](http://www.systembuild.com)

## ATTENTION

Le meuble peut basculer et causer des blessures graves ou la mort.

Ancrez le meuble à une planche murale dans le mur (si indiqué).

Ne laissez pas les enfants grimper sur le meuble.

Placez les articles lourds sur les étagères ou dans les tiroirs inférieurs.

## Astuces Utiles (page 2)

-Ouvrez votre article dans la zone que vous prévoyez de le garder pour moins de levage lourd

-Identifier, trier et compter les pièces avant d'essayer d'assembler

-Le panneau arrière doit être utilisé pour vous assurer que votre appareil est robuste

-N'utilisez pas de produits chimiques agressifs ou de nettoyeurs abrasifs sur cet appareil

-Ne jamais pousser, tirer, ou faire glisser votre meuble

## Avant de Commencer (page 2)

-Lisez attentivement chaque étape et suivez le bon ordre

-Séparez et comptez toutes vos pièces et matériaux

-Donnez-vous suffisamment de place pour l'assemblage

-Avoir les outils suivants: tournevis à tête plate, #2 tournevis Phillips, et Marteau

-Attention: Si vous utilisez une perceuse électrique ou un tournevis électrique pour visser, veillez à ralentir et arrêter lorsque la vis est bien serrée. Le non-respect de cette consigne peut endommager la vis.

## Identification des matériaux (Page 3)

Pas de taille réelle

- (A) CADRE GAUCHE
- (B) CÔTÉ DROIT DU CADRE
- (C) RAIL
- (D) DESSUS
- (E) TABLETTE FIXE
- (F) DESSOUS
- (G) RÉGLABLE GAUCHE
- (H) RÉGLABLE DROITE
- (I) PANNEAU ARRIÈRE SUPÉRIEUR
- (J) PANNEAU ARRIÈRE INFÉRIEUR

## Numéro de référence du sac de quincaillerie:

**22498013COM0DM**

## Liste des pièces (Page 5)

Taille réelle

- (1) VIS
- (3) ANCRAGE MURAL
- (4) VIS

Pas de taille réelle

- (2) SUPPORT MURAL

### Page 6

Fixez (F) à (A) & (B) comme indiqué ci-dessous.

### Page 7

Fixez (E) à (A) & (B) comme indiqué ci-dessous.

### Page 8

Fixez (C) à (E) & (F) comme indiqué ci-dessous.

### Page 9

Fixez (C) à (E) & (F) comme indiqué ci-dessous.

### Page 10 & 15

Fixez (2) à (C) comme indiqué ci-dessous.

Fixez (C) à (A) & (B) comme indiqué ci-dessous.

### Page 11 & 16

Fixez (F) & (G) à (A) & (B) comme indiqué ci-dessous.

### Page 12 & 17

Fixez (F) & (G) à (A) & (B) comme indiqué ci-dessous.

### Page 13 & 18

Fixez (H) à (A) & (B) comme indiqué ci-dessous.

**IMPORTANT: CET APPAREIL DOIT ÊTRE SÛR AU MUR POUR AIDER À PRÉVENIR BASCULER. SUIVRE CES INSTRUCTIONS POUR INSTALLER LE SUPPORT DE SÉCURITÉ ANTI-BASCULEMENT FOURNIS AVEC CE PRODUIT.**

## **ATTENTION**

**Blessures par écrasement graves ou mortelles peuvent se produire des meubles renversement.**

**Pour éviter tout renversement:**

- \* Installer la retenue de renversement fourni
- \* Place des objets les plus lourds dans les tiroirs les plus bas
- \* Sauf spécifiquement conçu pour accueillir, ne réglez pas les téléviseurs ou d'autres objets lourds sur le dessus de ce produit
- \* Ne jamais laisser les enfants grimper ou se bloquer sur les tiroirs, portes, ou des étagères
- \* Ne jamais ouvrir plus d'un tiroir à la fois

**Utilisation de restarints de Tipover ne peut réduire, mais pas éliminer le risque de renversement**

OPTION 1: Fixation sur un montant mural (méthode préférée)

L'utilisation d'un détecteur de montants, repérez un Studin le mur. Placez votre appareil contre le mur, avec le support aligné à cet endroit.

Pour rendre la conduite plus facile la vis, vous pouvez percer un trou pilote de 1/8 "de diamètre (3 mm) à travers le support dans le goujon.

Conduisez la vis (10) à travers le support dans le montant du mur.

OPTION 2: Fixation dans une cloison sèche

Localisez votre unité où désiré contre un mur et marquer le mur à travers le support de sécurité (11a), puis déplacez votre unité de côté

Percez un trou de 3/16 "de diamètre (5 mm) dans la plaque de plâtre. Appuyez sur l'ancrage dans le trou jusqu'à ce qu'elle affleure.

Déplacez-vous l'unité dans l'emplacement et fixez le support mural (9) à l'ancre de avec la vis (10).

Pour la maçonnerie, béton ou d'autres matériaux de mur:

Consultez votre magasin local de matériel pour les ancrages appropriés pour fixer le support de sécurité en toute sécurité.

## Page 20

### CHARGES MAXIMALES

Ce meuble a été conçu pour supporter les charges maximales indiquées. En excédant ces limites de charge, le meuble pourrait devenir instable, s'effondrer, et/ou causer des blessures graves.

**AVERTISSEMENT :** Risque de blessure corporelle - ne pas placer une télévision sur ce meuble. Ce meuble n'est pas approuvé pour une utilisation avec une télévision.

## Page 21

Enregistrez votre produit pour recevoir les éléments suivantes:

- \* Détails sur les nouvelles tendances - un aperçu sur les nouveautés
- \* Sondages - avoir une voix au sein de notre communauté
- \* Offres exclusives et codes promo
- \* Service de pièces de rechange rapide et facile

Pour enregistrer votre produit, visitez [systembuild.com](http://systembuild.com)

### 5 Étoiles

Visitez le site Web de votre détaillant local, évaluez votre produit acheté et laissez-nous quelques commentaires !

Nous tenons à offrir un grand "Merci" à tous nos clients pour avoir pris le temps d'assembler ce produit "Systembuild", et de nous donner vos commentaires précieux.

Merci