

8639335COM 55 Gallon Aquarium Stand

Ameriwood
HOME

Date of Purchase ___ / ___ / ___
Lot Number:

B348639335COM0

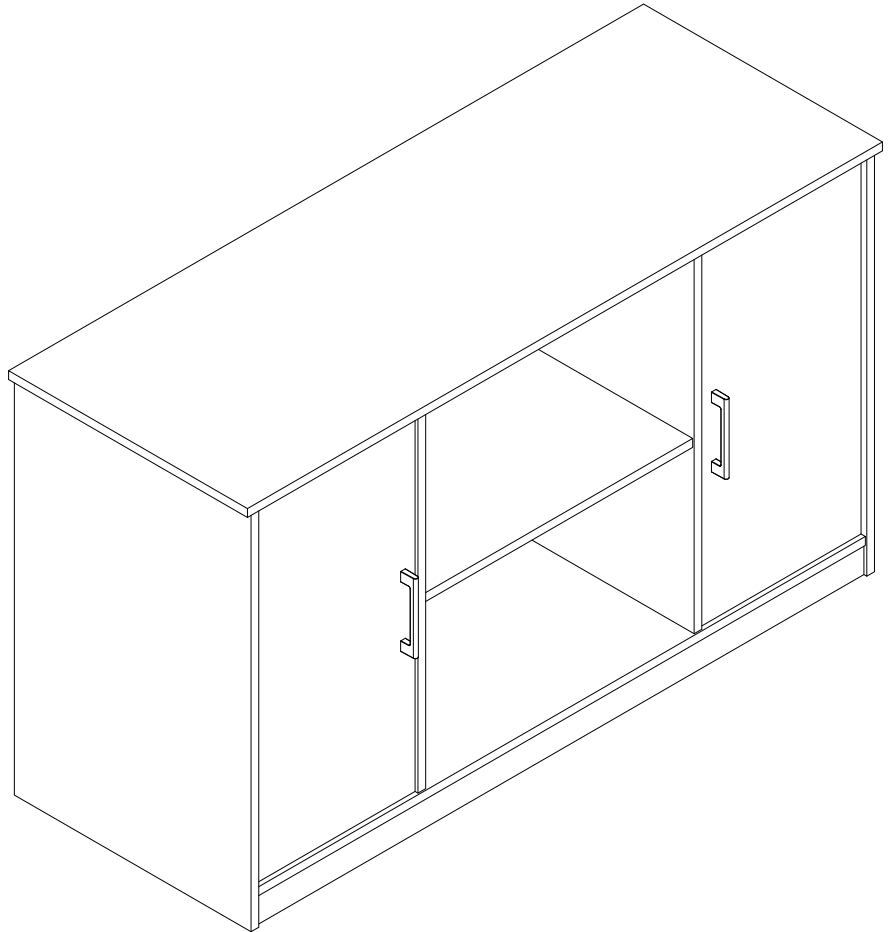

THIS INSTRUCTION BOOKLET CONTAINS **IMPORTANT** SAFETY INFORMATION. PLEASE READ AND KEEP FOR FUTURE REFERENCE.

Do Not Return This Product!

Contact our customer service team for help first.

Call: 1-800-489-3351 (toll free)

Visit: www.ameriwoodhome.com



WARNING

- Unit can tip over causing severe injury or death.
- Anchor unit to stud in wall (if instructed to).
- Do Not allow children to climb on unit.
- Put heavy items on lower shelves or drawers.

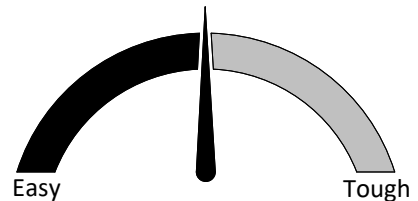

Assembly Difficulty Meter

Follow Ameriwood Home



Contact Us!

Do NOT return this product!

Contact our friendly customer service team first for help.

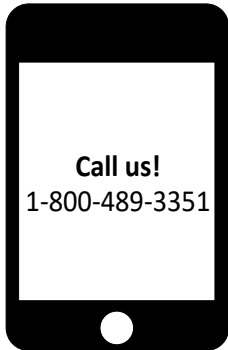

Visit ameriwoodhome.com to view the limited warranty valid in the U.S. and Canada.

Assembly Tips



Helpful Hints

PEOPLE NEEDED FOR ASSEMBLY: 1-2

- Open your item in the area you plan to keep it to avoid excessive heavy lifting.
- Identify, sort and count the parts before attempting assembly.
- Compression dowels are lightly tapped in with a hammer.
- Make sure to always face the point on the top of the Cam Lock towards the outer edge.
- Do NOT use harsh chemicals or abrasive cleaners on this item.
- Never push, pull, or drag your furniture.

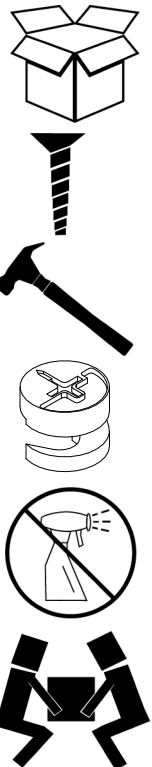

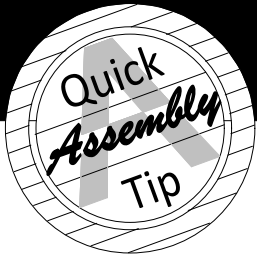

Before You Start

- ✓ Read through each step carefully and follow the proper order
- ✓ Separate and count all your parts and hardware
- ✓ Give yourself enough room for the assembly process
- ✓ Have the following tools: #2 Phillips Head Screwdriver and Hammer
- ✓ Caution: If using a power drill or power screwdriver for screwing, please be aware to slow down and stop when screw is tight. Failure to do so may result in stripping the screw.

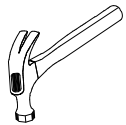
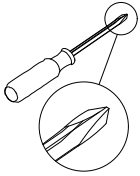

Cam Lock Fastening System

This Cam Lock Fastening System will be used throughout the assembly process.

- 1**

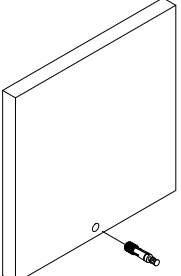

Press CAM BOLT into hole.
- 2**

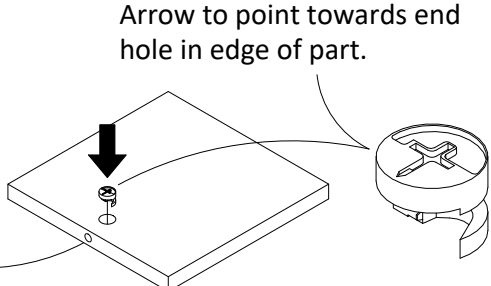

Arrow to point towards end hole in edge of part.

End hole

Press CAM LOCK into hole.
- 3**

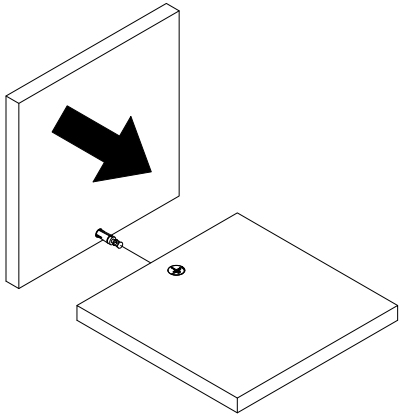

Press parts together so CAM BOLT inserts into edge hole.
- 4**

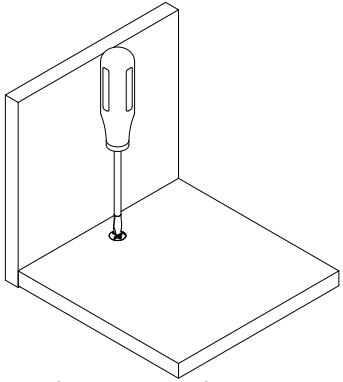

Using a screwdriver, turn the CAM LOCK clockwise to lock the CAM LOCK and CAM BOLT into their holes and fastening parts together.

Board Identification

Not actual size

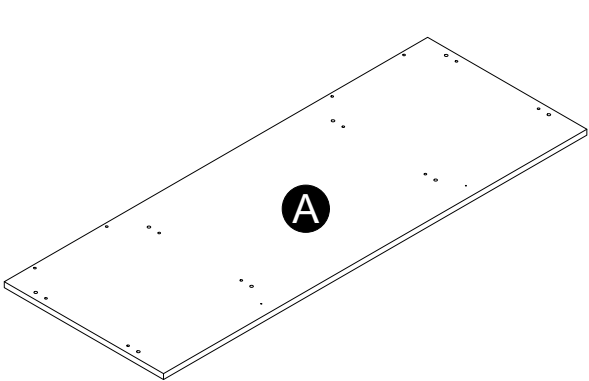

Top
38639335010

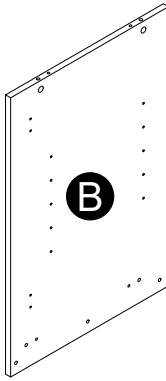

Left Side
38639335020

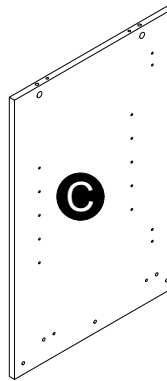

Right Side
38639335030

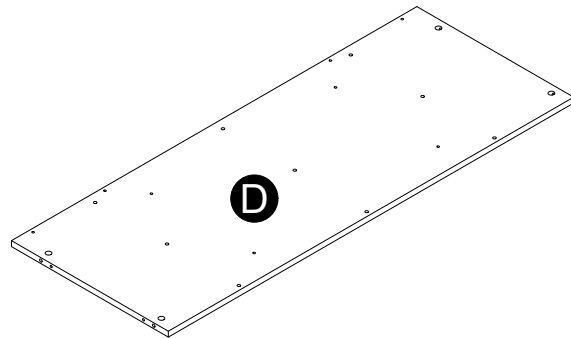

Bottom
38639335040

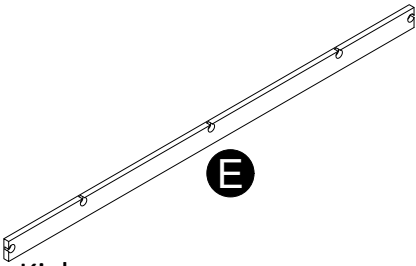

Kick
38639335050

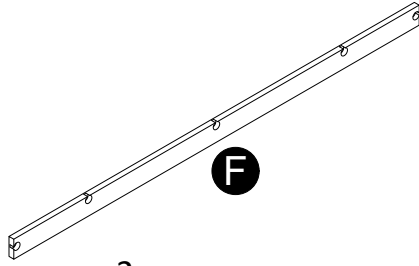

x2
Bottom Support
38639000060

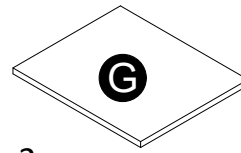

x2
Adjustable Shelf
38639335070

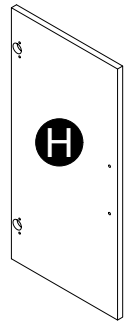

x2
Door
38639335080

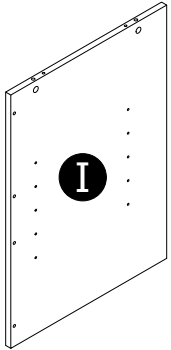

Left Partition
38639335090

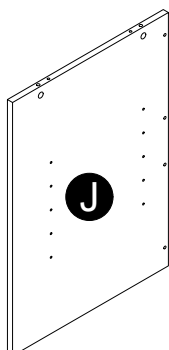

Right Partition
38639335100

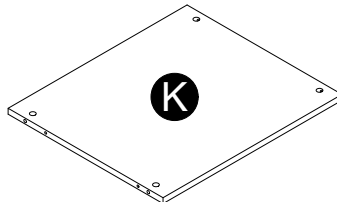

Mid Shelf
38639335110

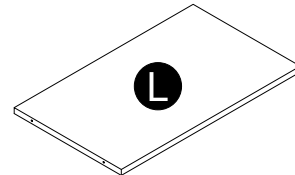

x2
Mid Back
38639335120

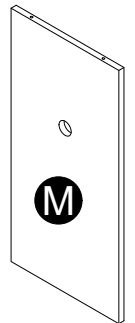

x2
Back
38639335130

Board Identification

Not actual size

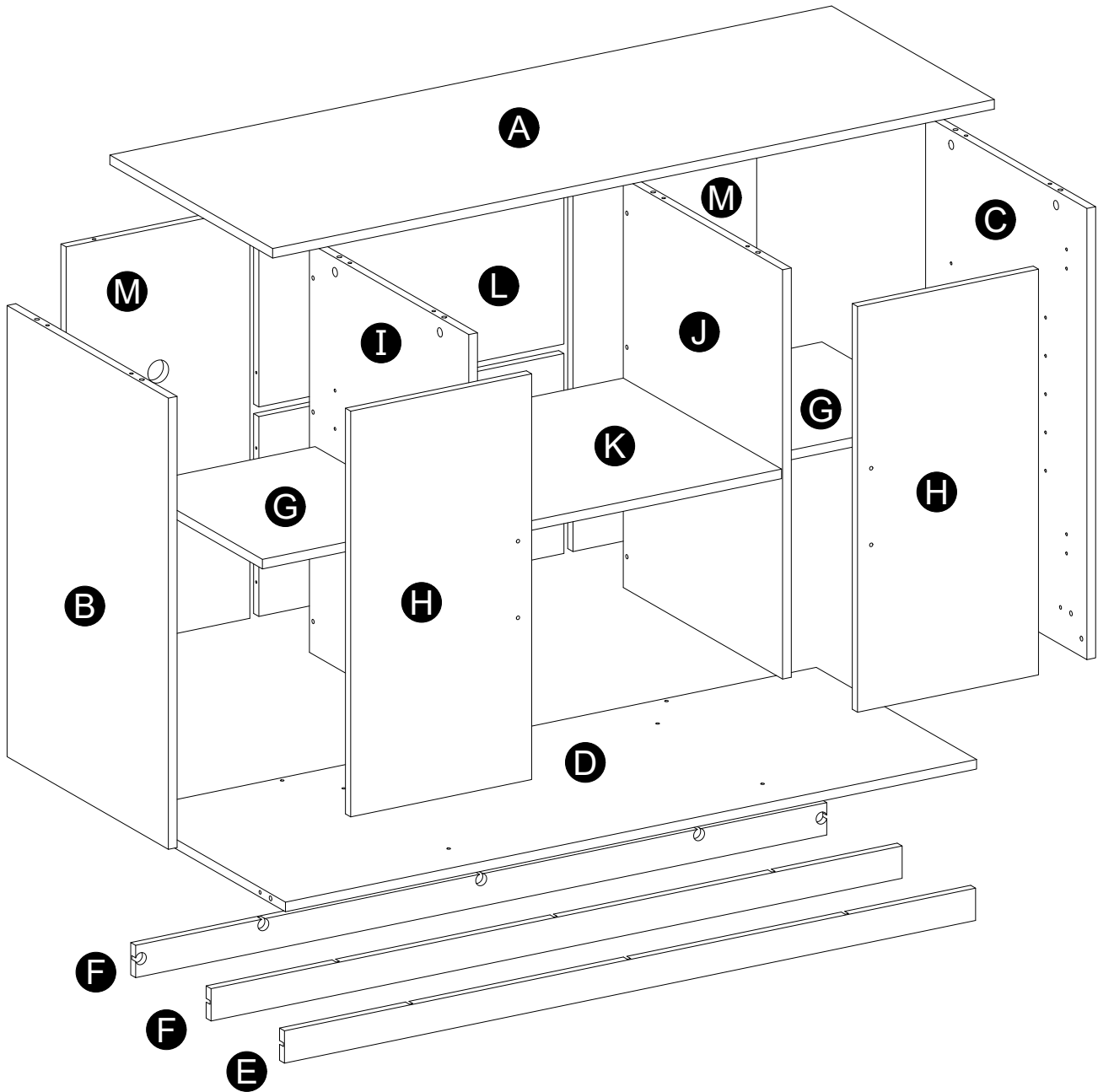

Part List

Actual Size

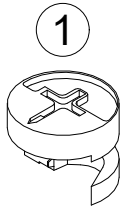

(x16)
#A22700
cam lock



(x16)
#A22710
cam bolt

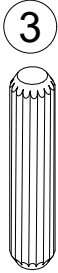

(x20)
#A21660
wood dowel

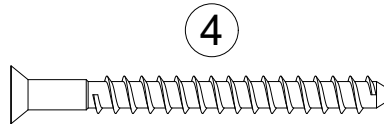

(x16)
#A23030
confirmat screw

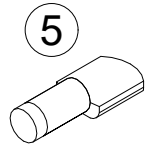

(x8)
#A80250
shelf support

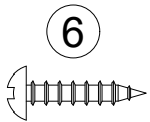

(x2)
#A11170
#6 x 5/8" pan

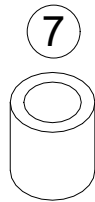

(x2)
#A89020
support pin

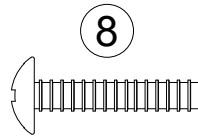

(x4)
#A17400
7/8" bolt

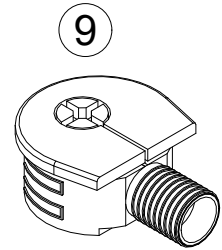

(x15)
#A22760
quicklock

Not Actual Size

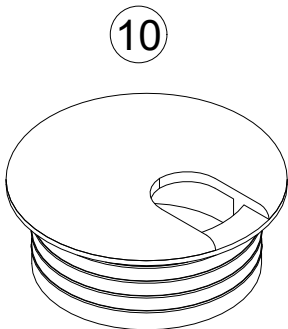

(x2)
#A70310
grommet w/cap

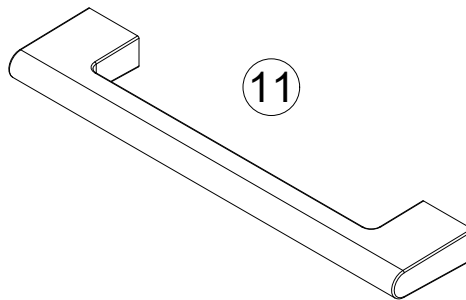

(x2)
#A50415
handle

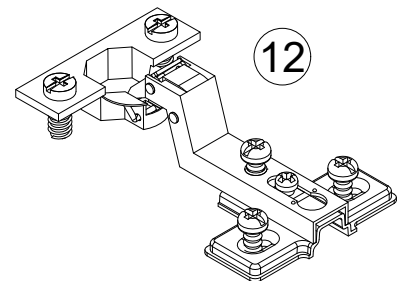

(x4)
#A65640
hinge

STEP 1

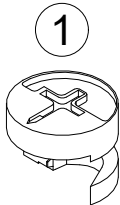
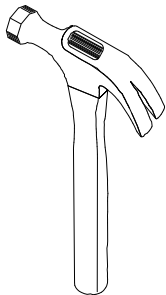

(x2)

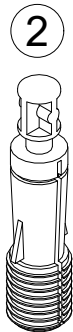

(x2)

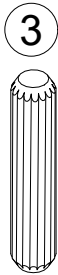

(x2)

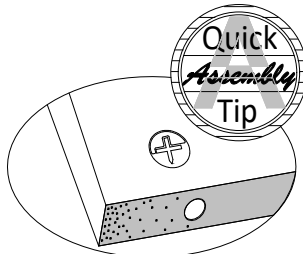

Proper orientation of CAM LOCK

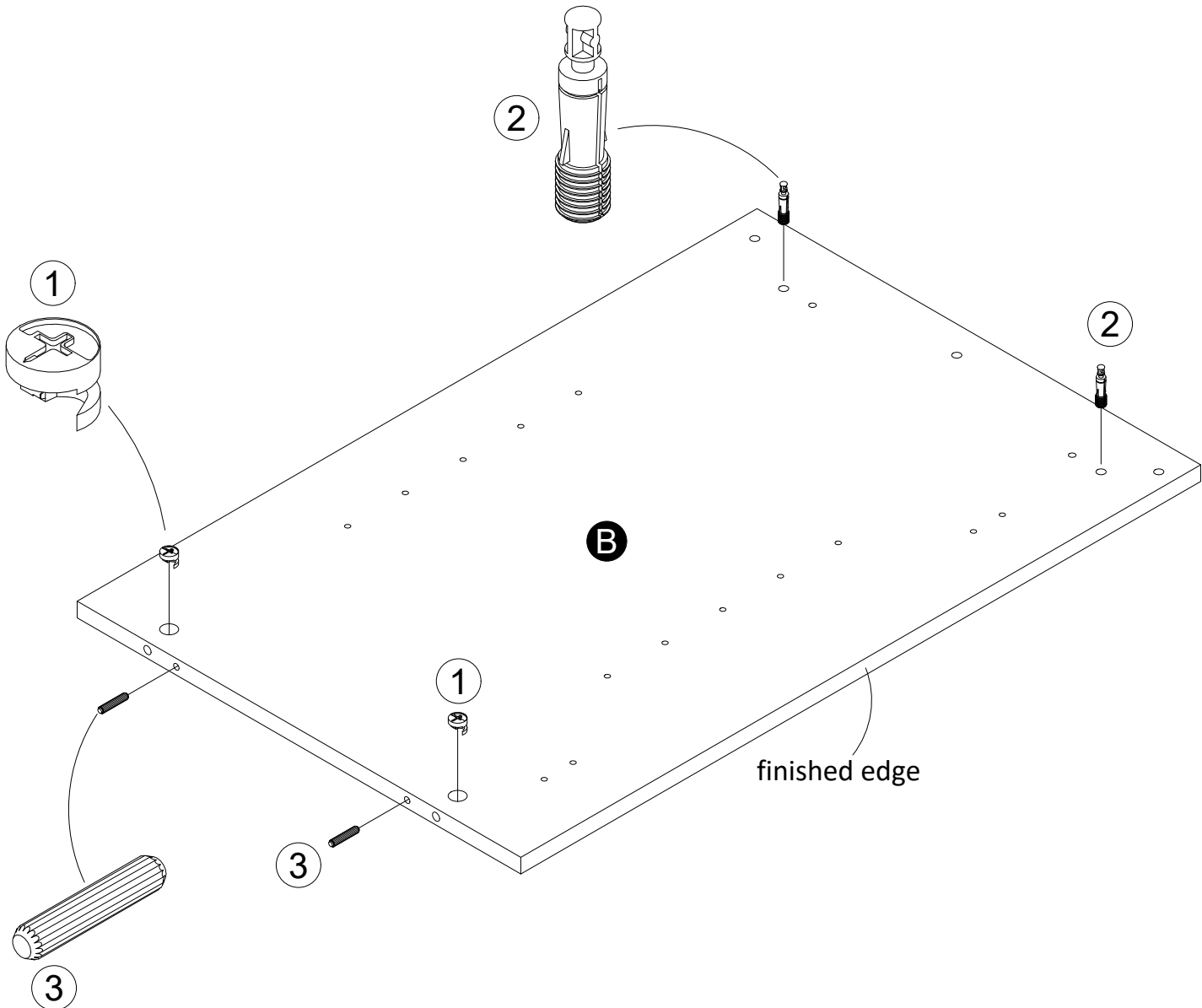
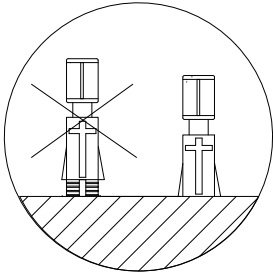

STEP 2

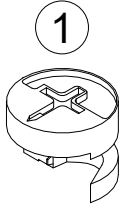
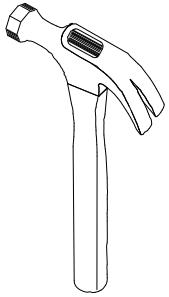

(x2)

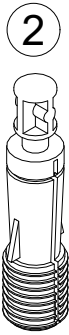

(x2)

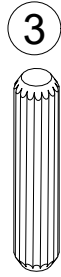

(x2)

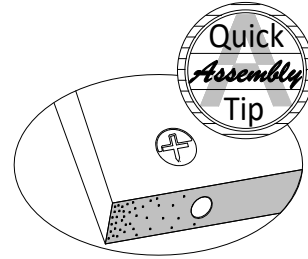

Proper orientation of CAM LOCK

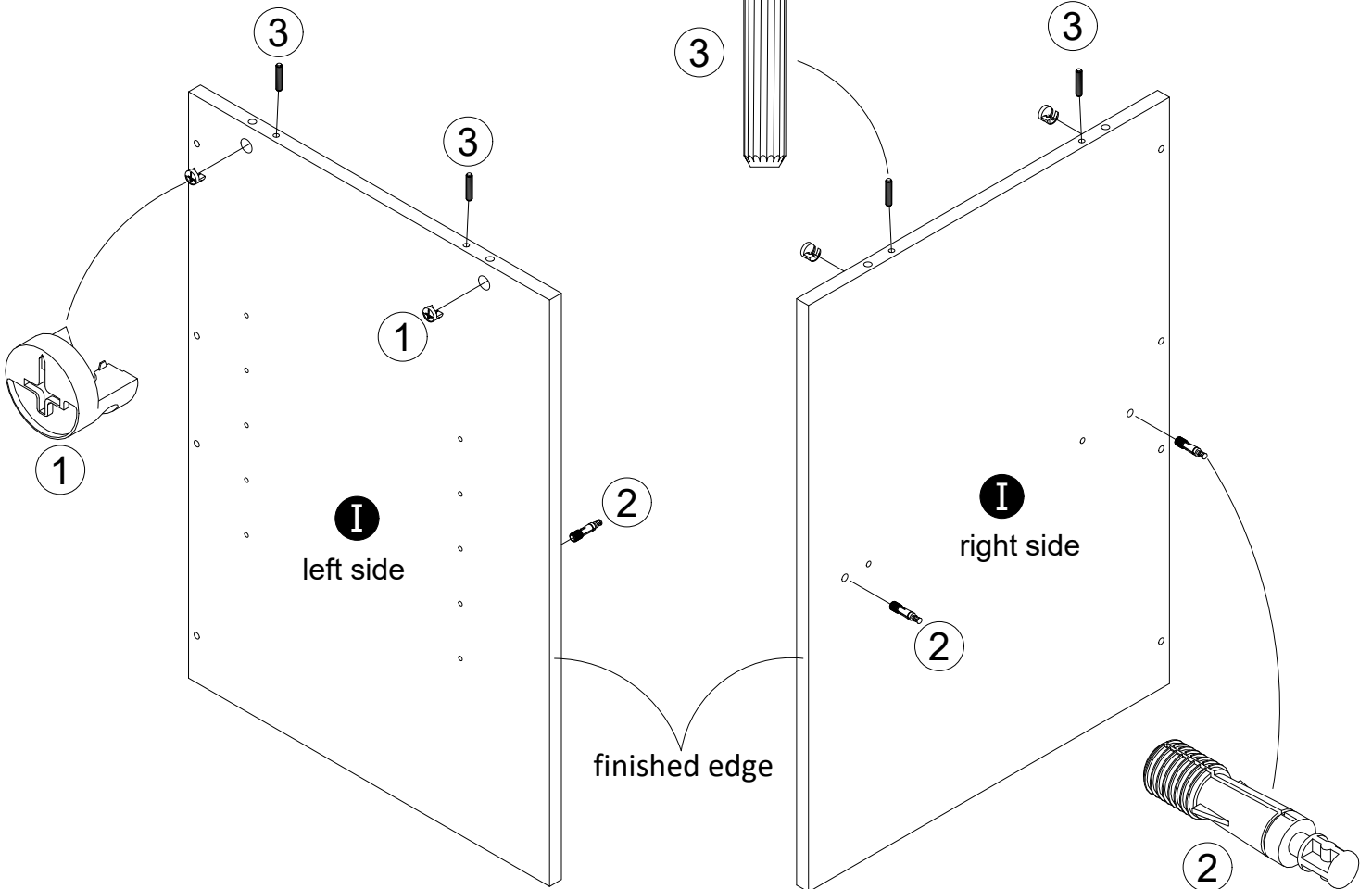
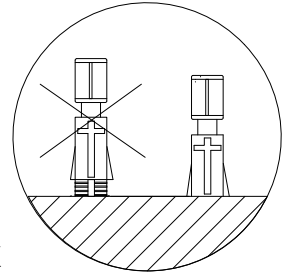

STEP 3

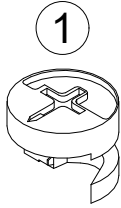
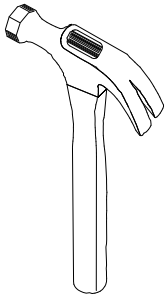

(x2)

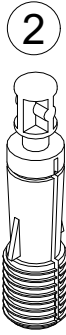

(x2)

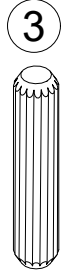

(x2)

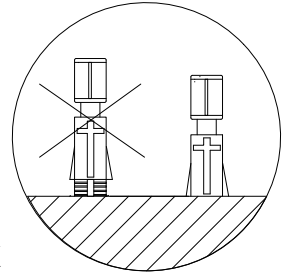
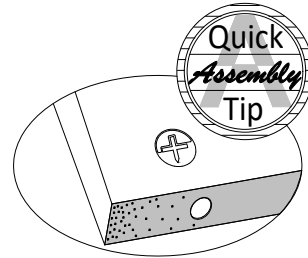

Proper orientation of CAM LOCK

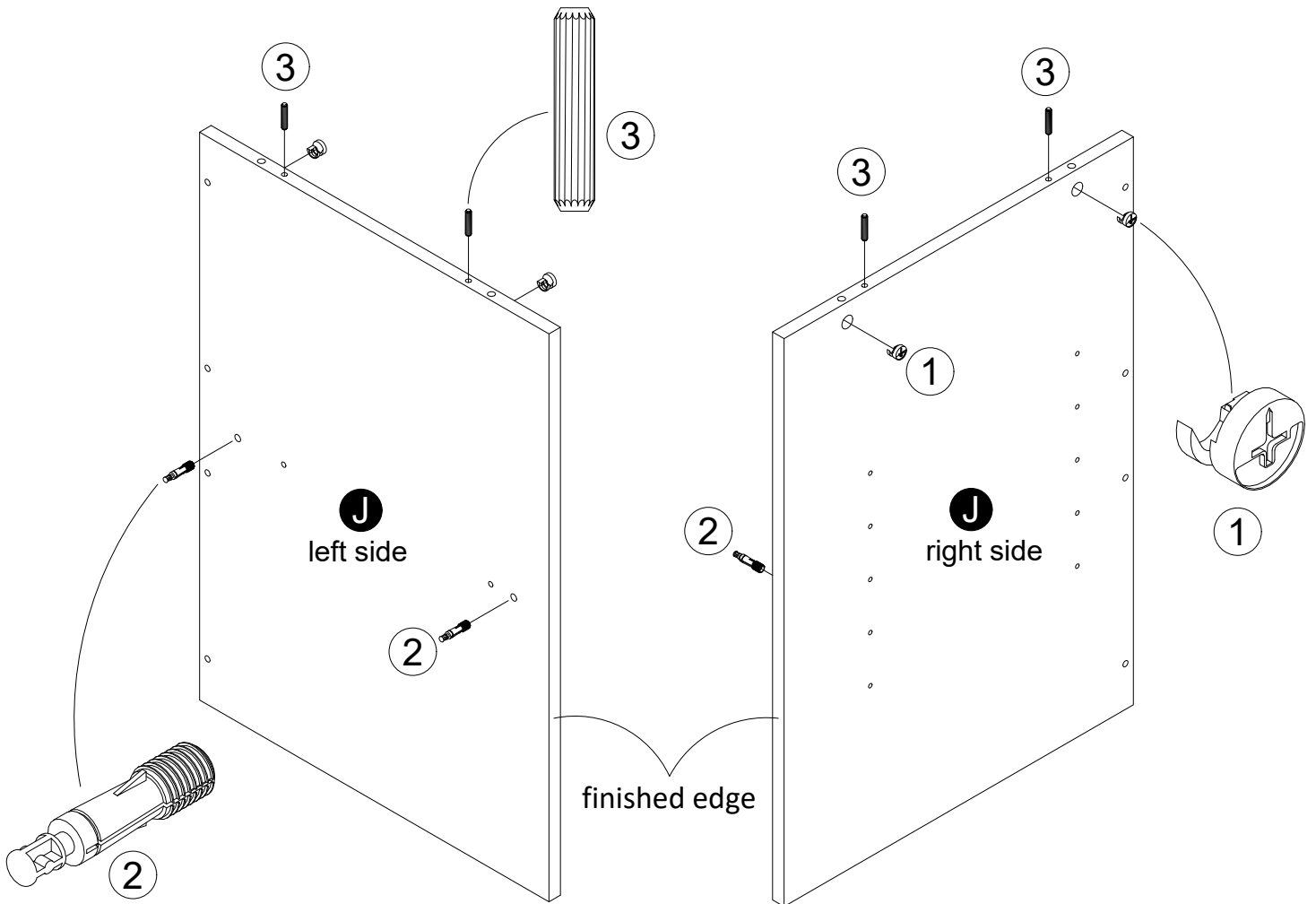

STEP 4

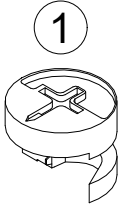
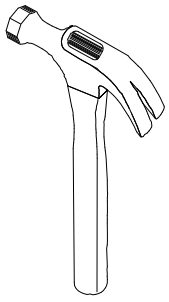

(x2)

2



(x2)

3

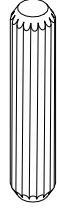

(x2)

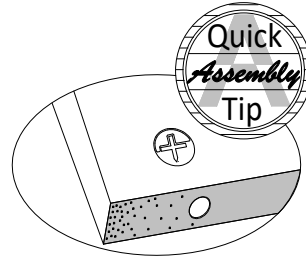

Proper orientation of CAM LOCK

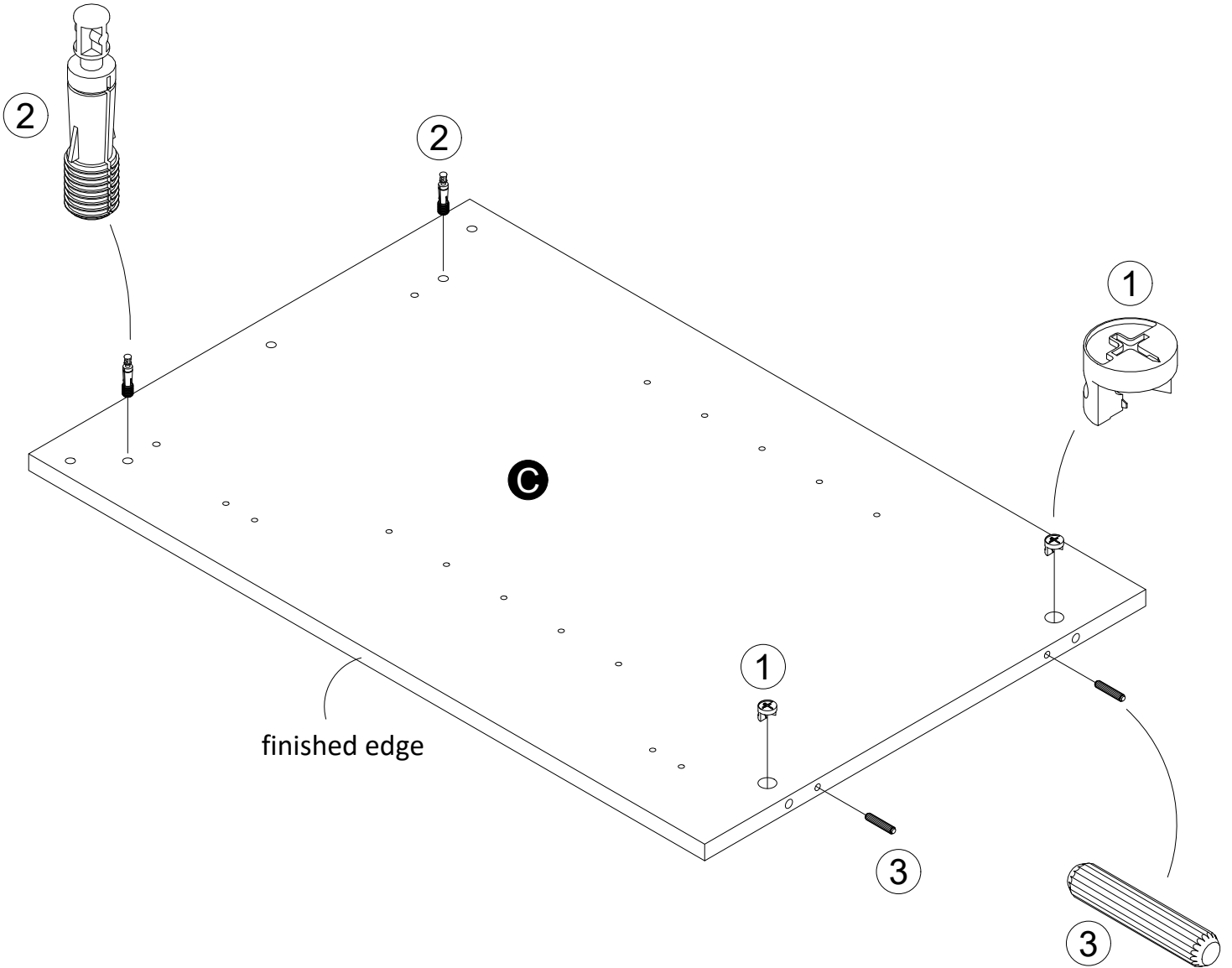
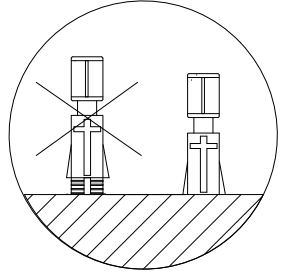

STEP 5

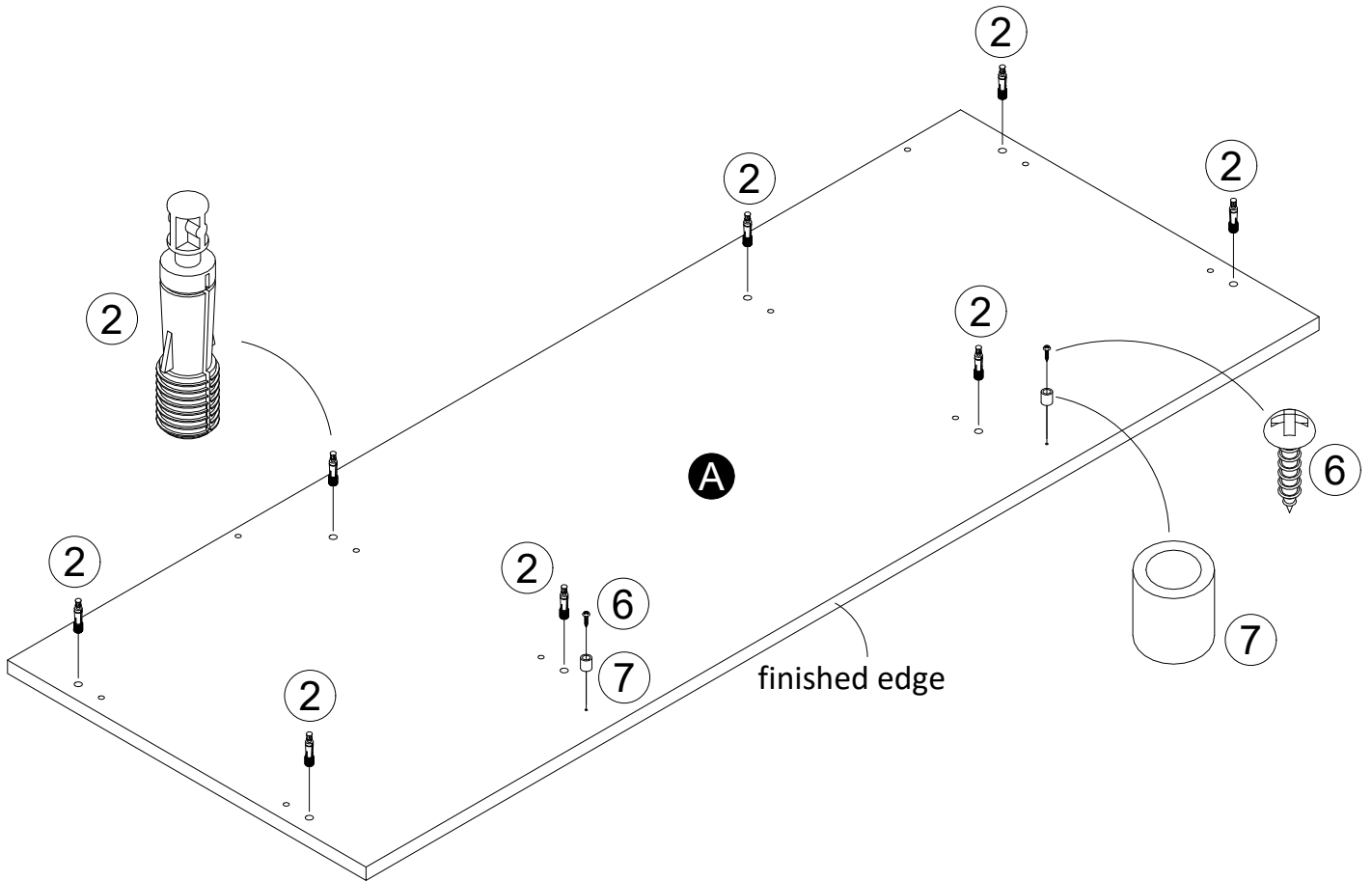
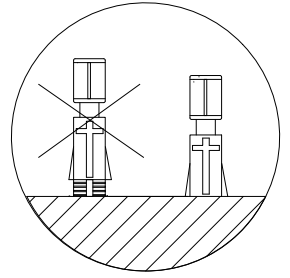
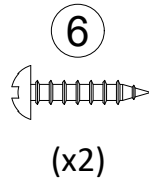
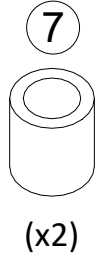
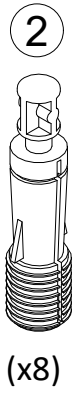
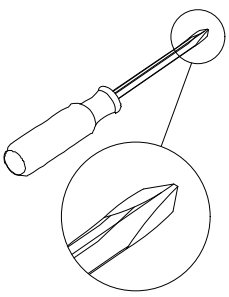

STEP 6

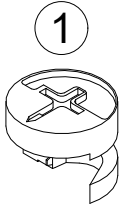
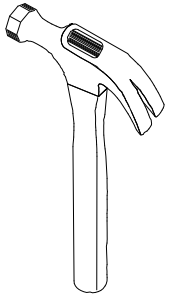

(x4)



(x4)

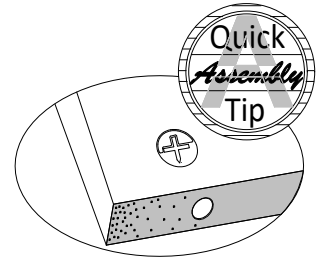

Proper orientation of CAM LOCK

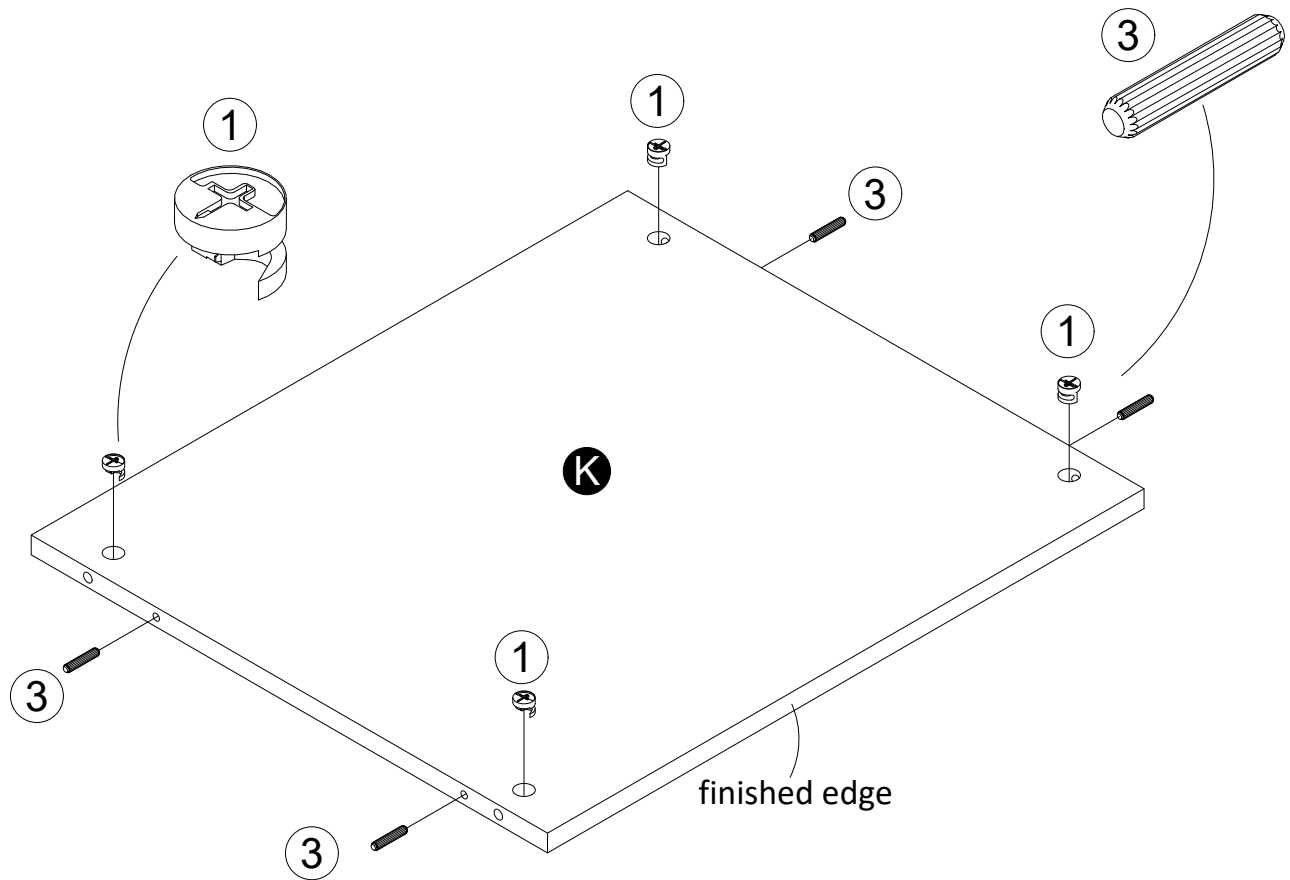

STEP 7

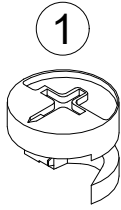
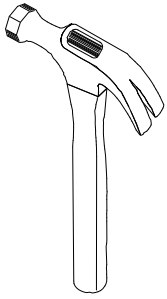

(x4)

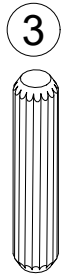

(x4)

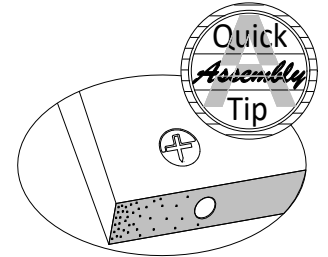

Proper orientation of CAM LOCK

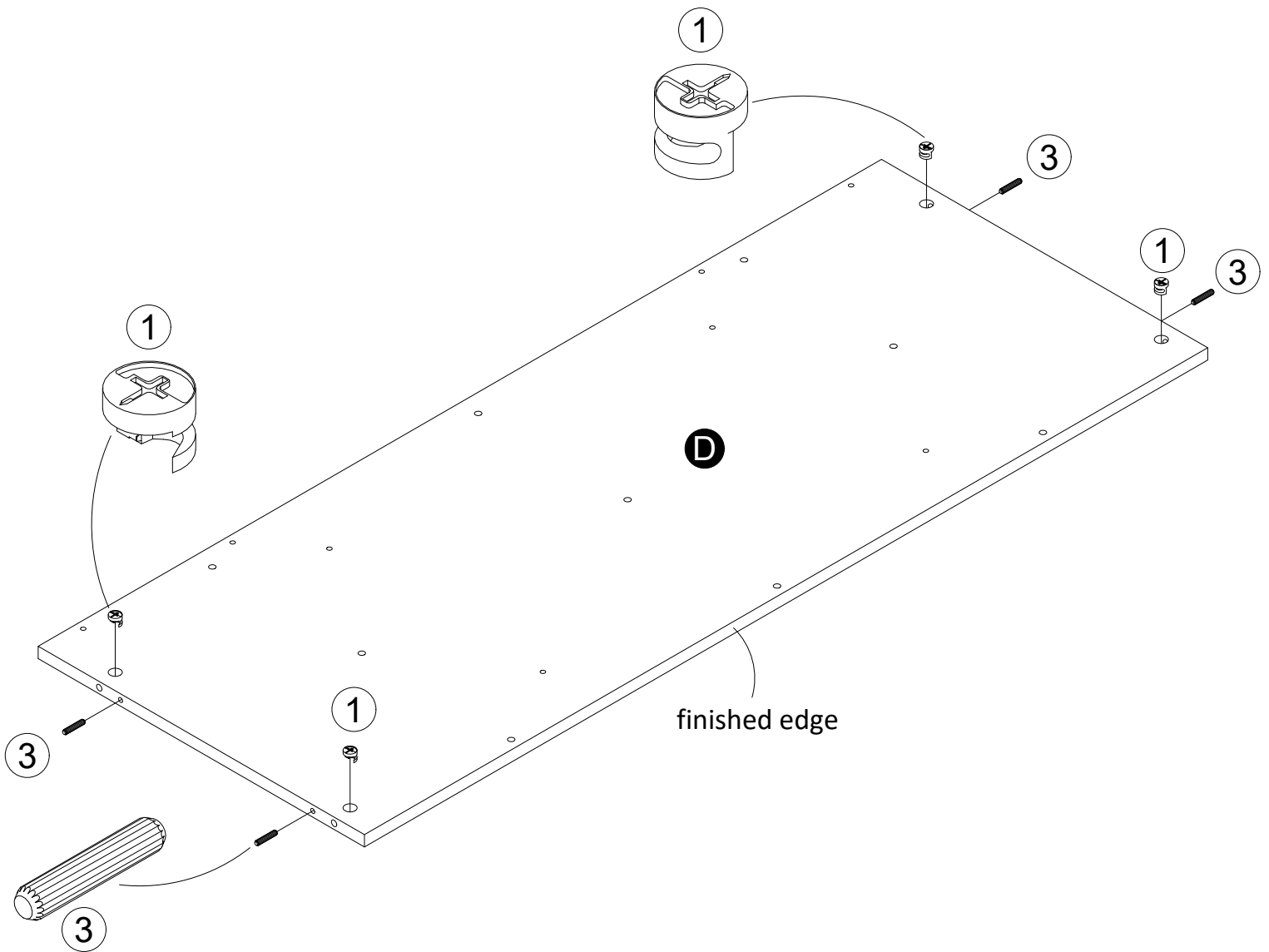

STEP 8

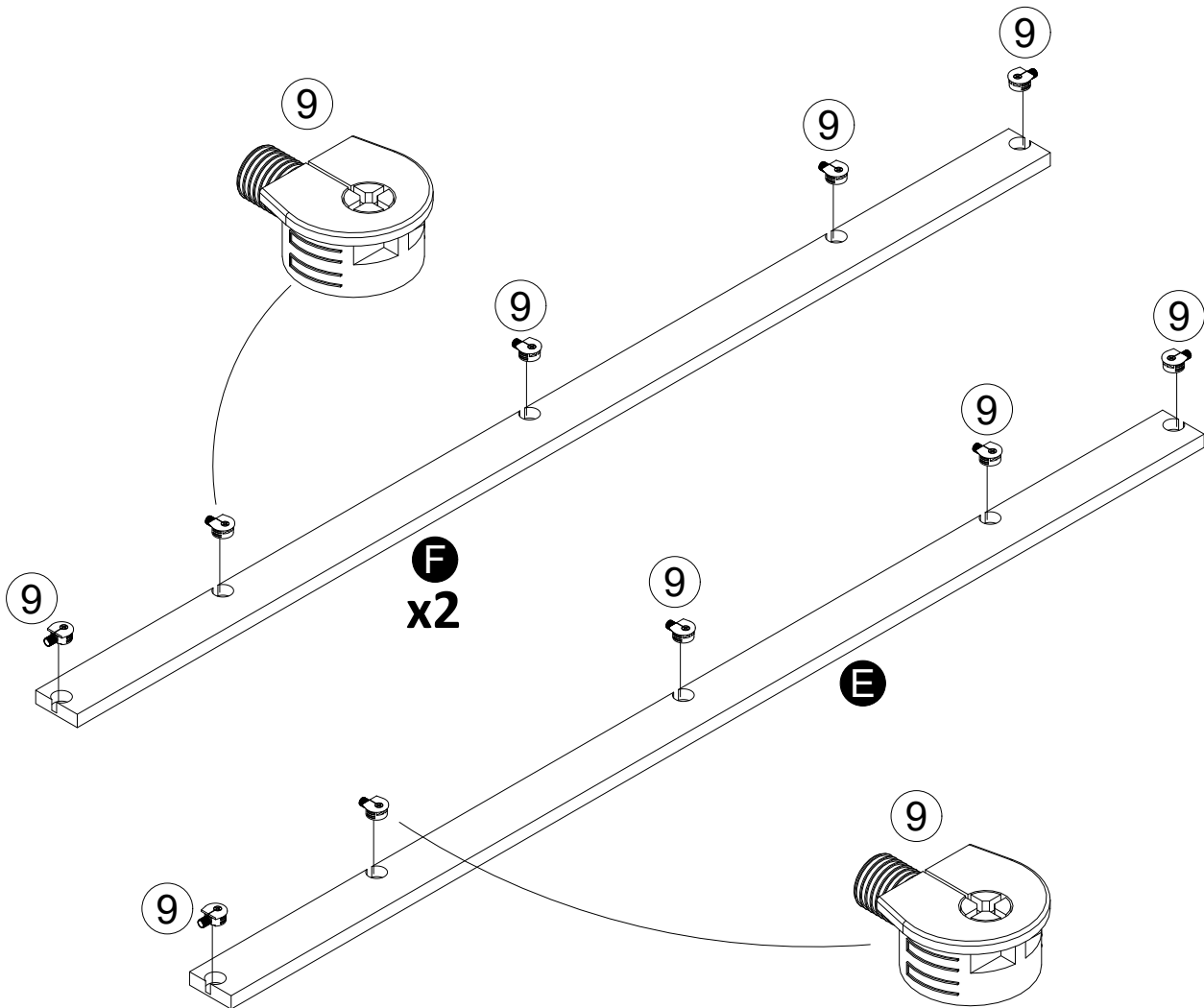
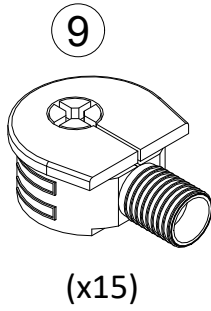
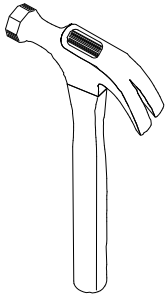

STEP 9

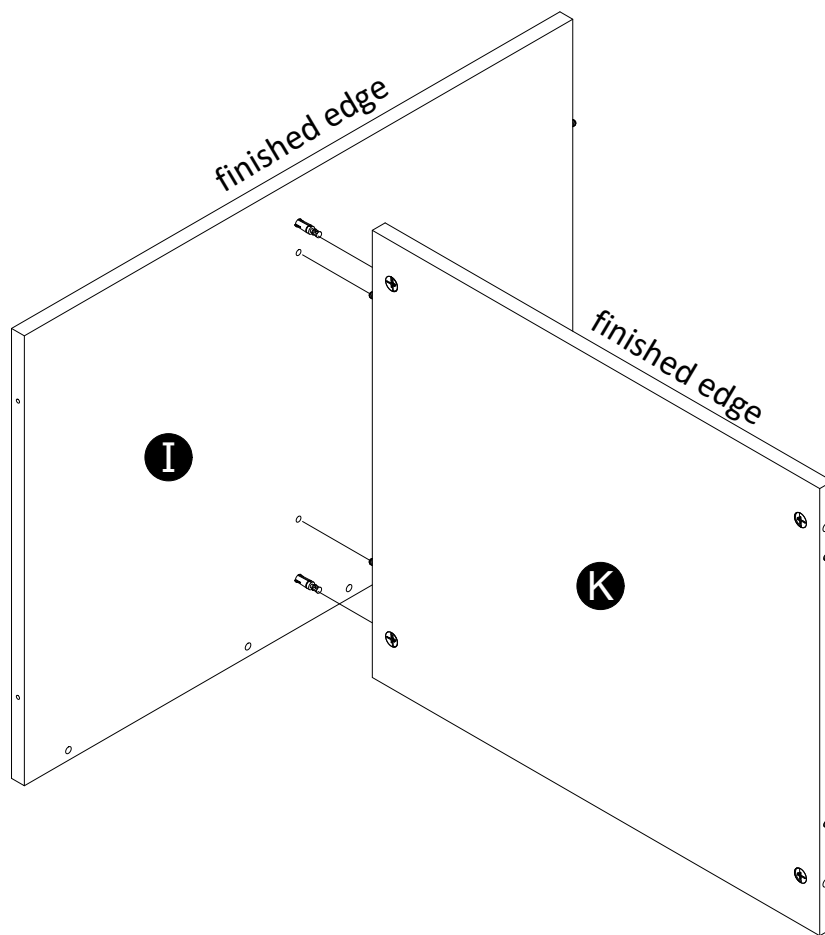
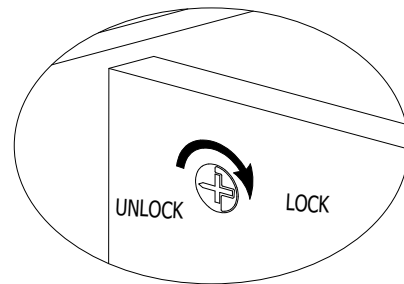
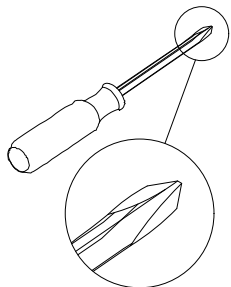

STEP 10

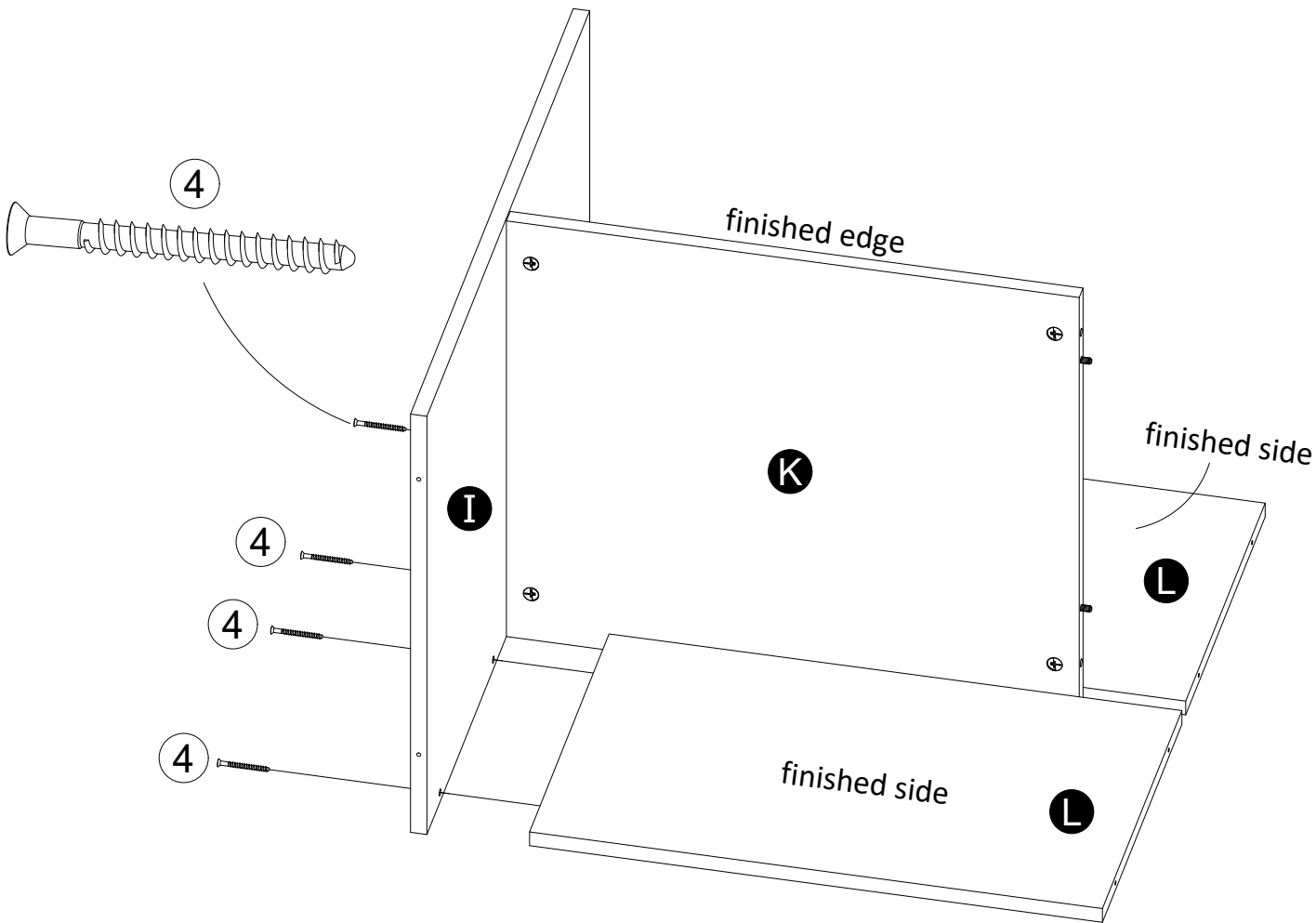
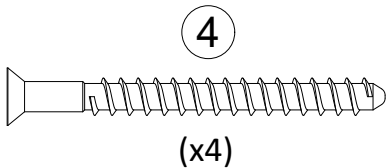
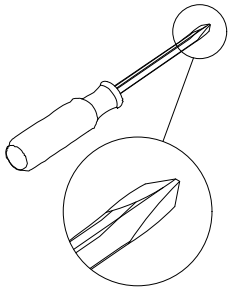

STEP 11

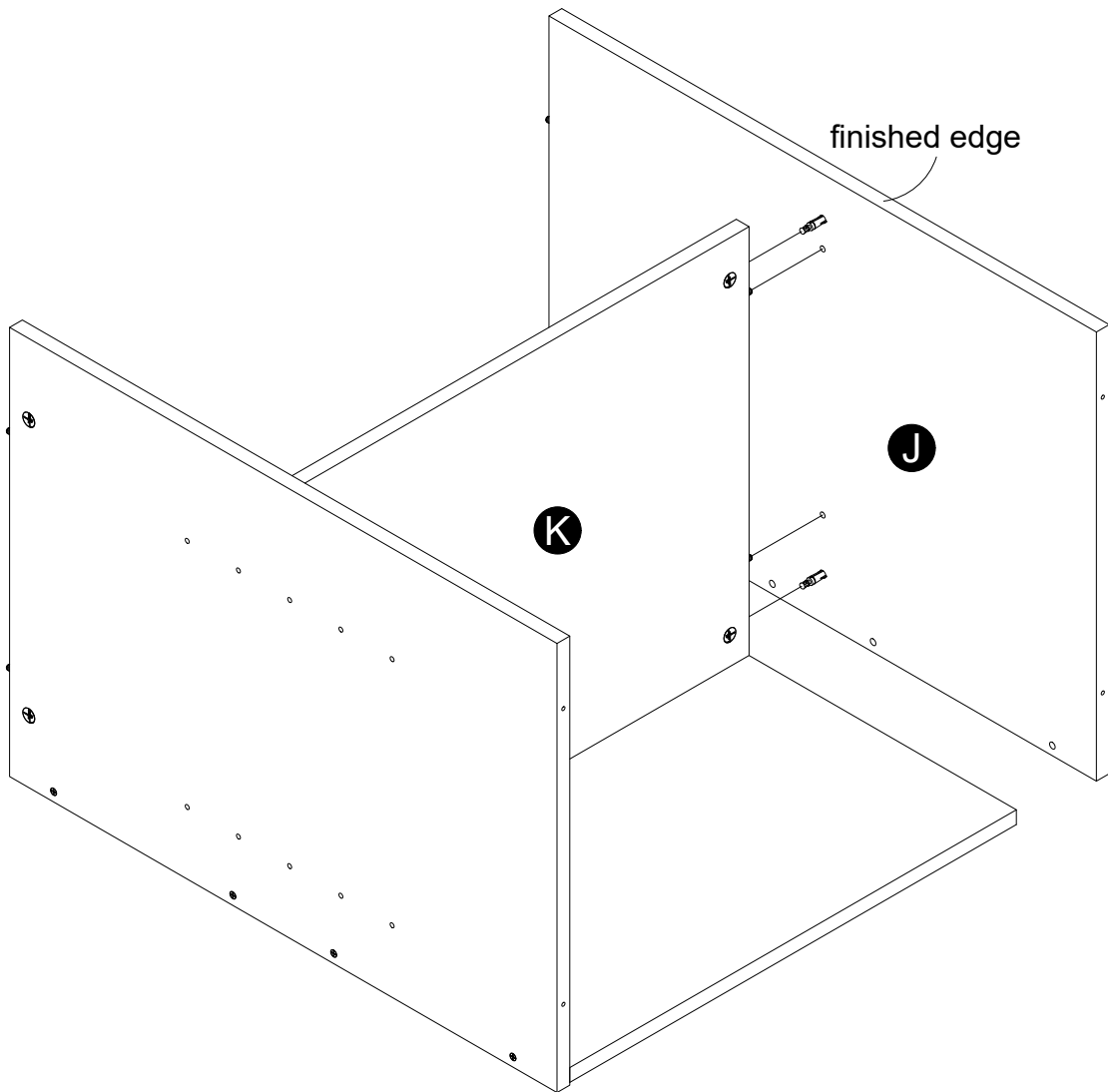
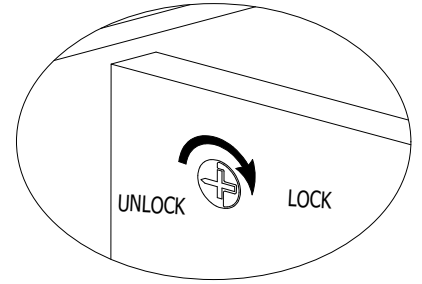
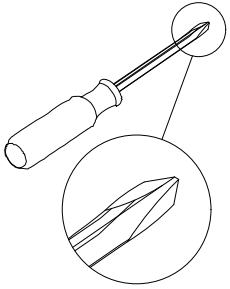

STEP 12

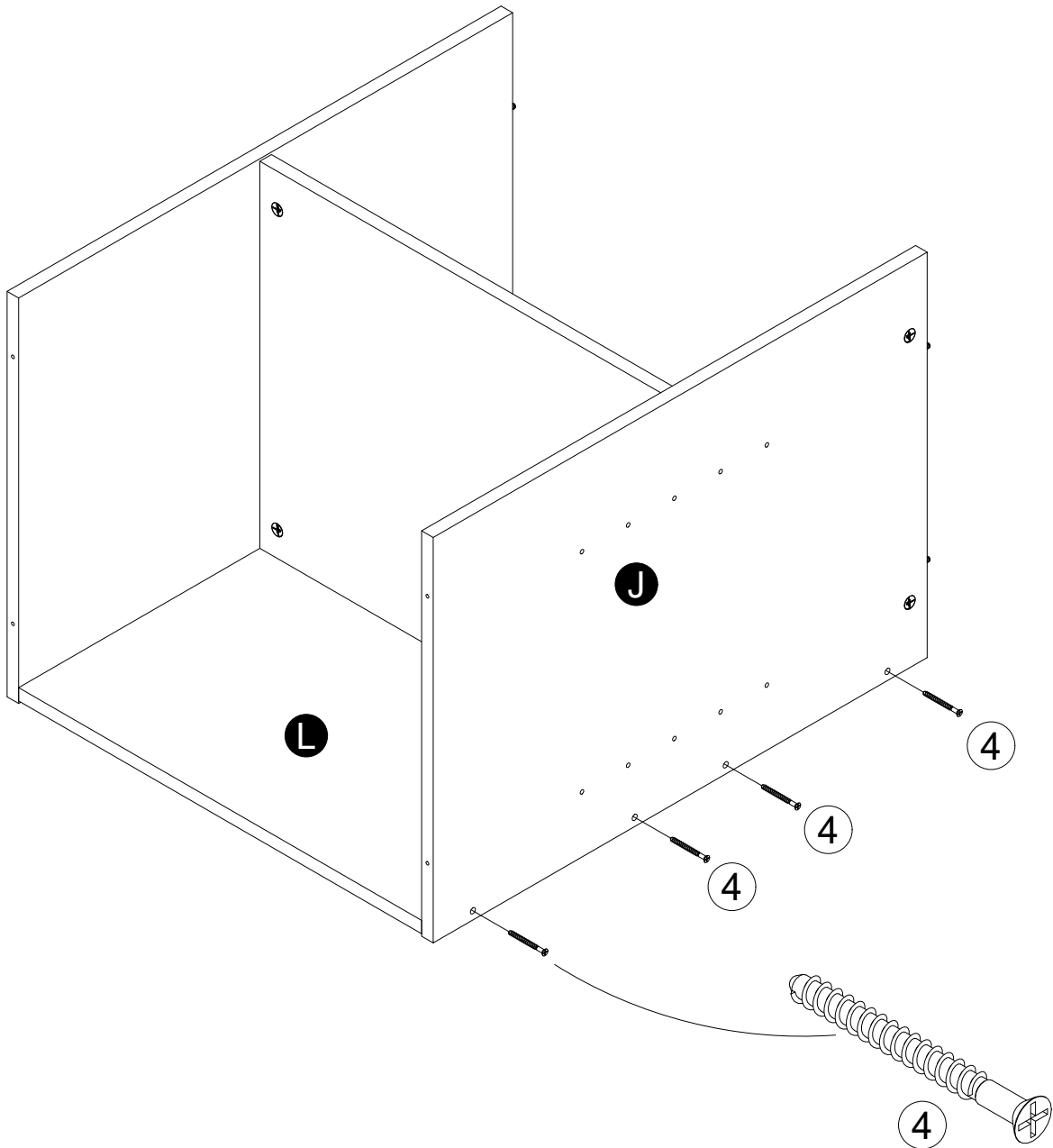
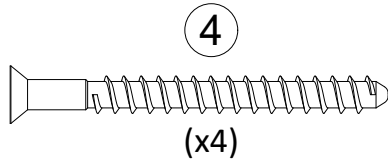
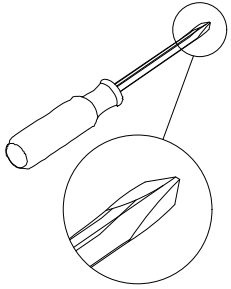

STEP 13

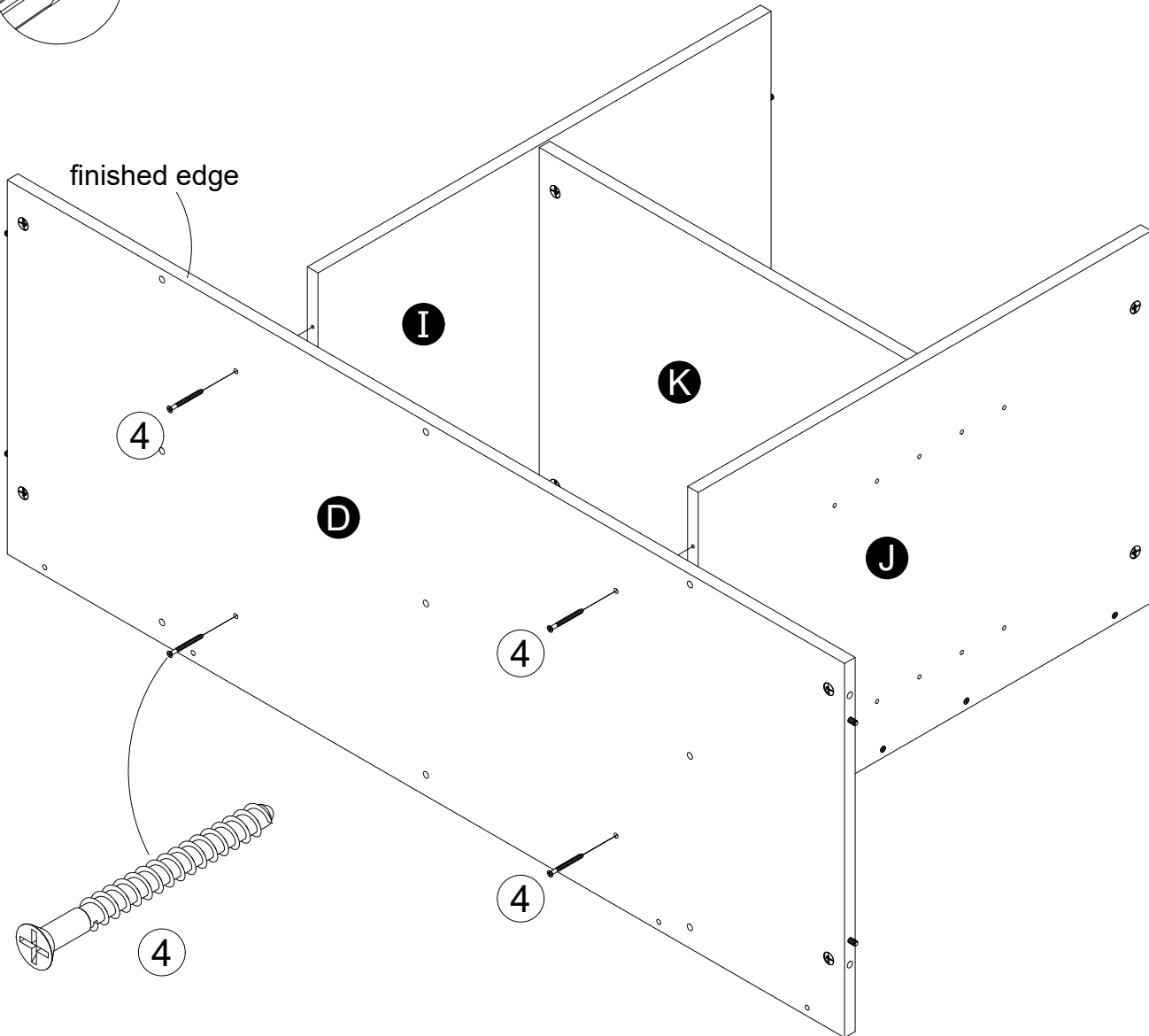
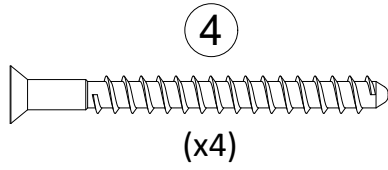
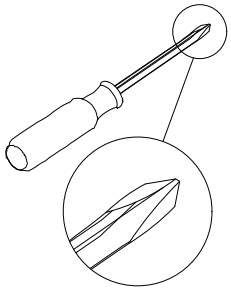

STEP 14

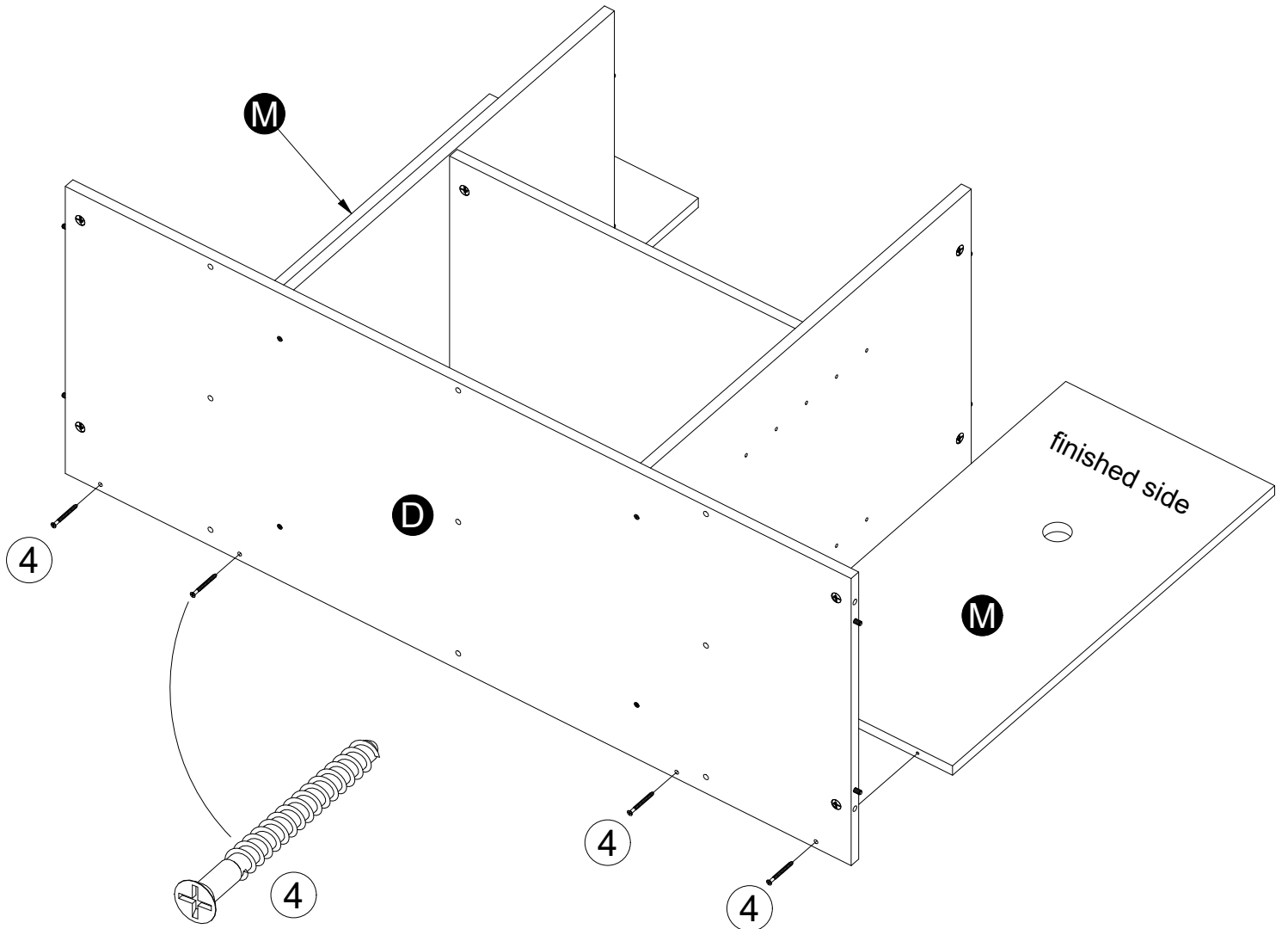
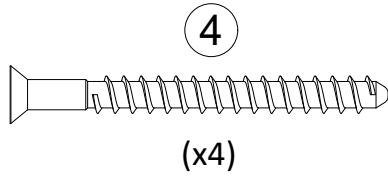
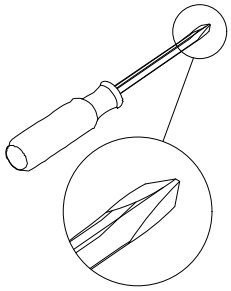

STEP 15

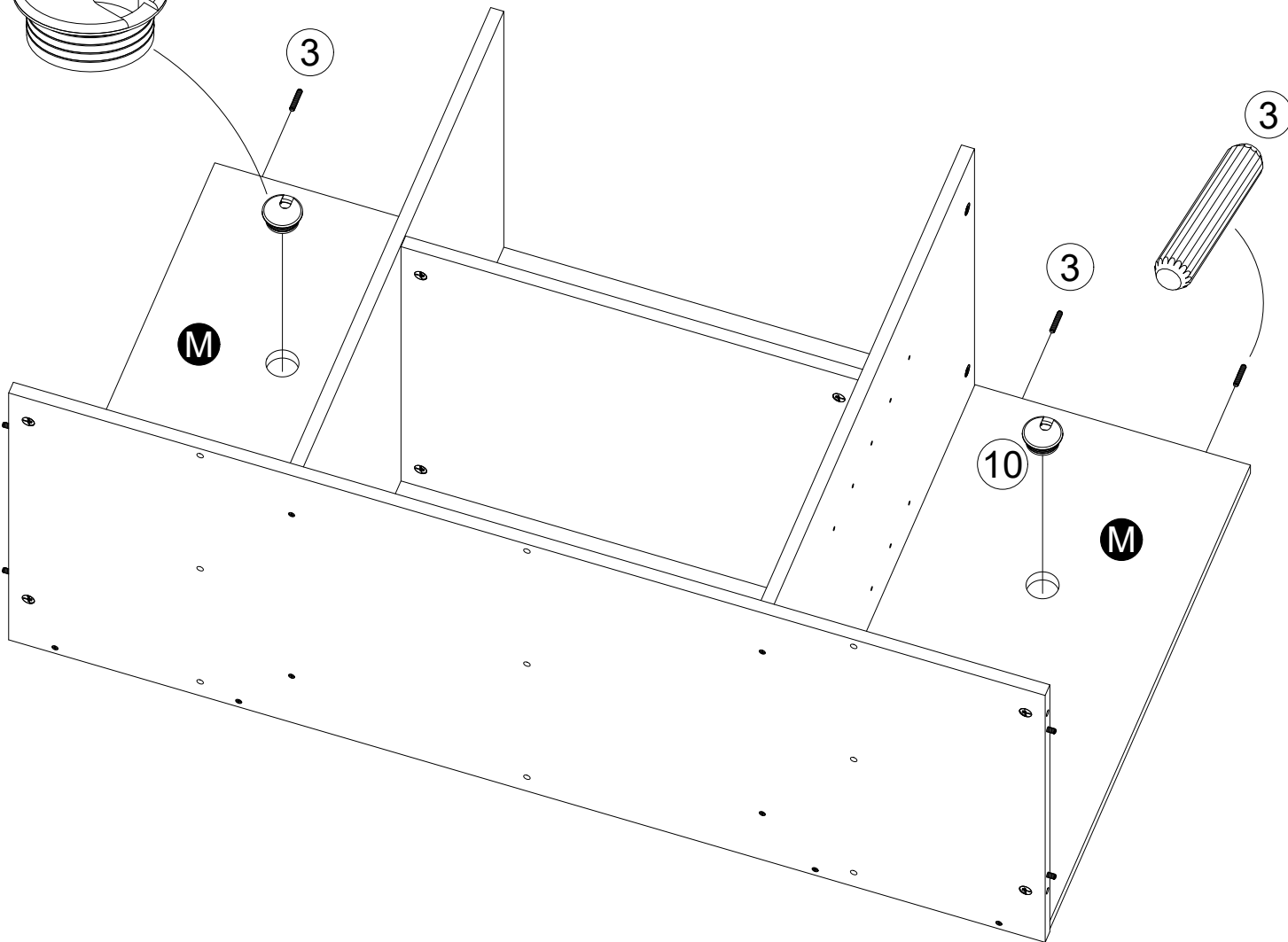
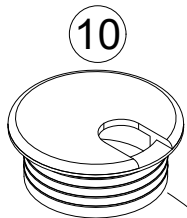
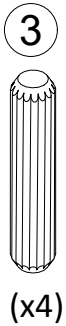
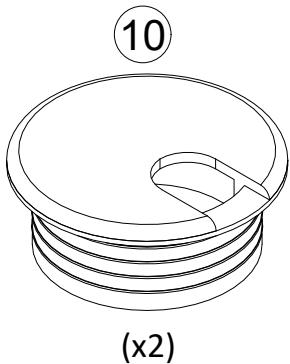
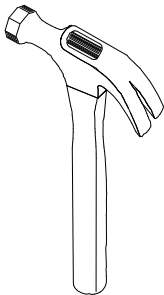

STEP 16

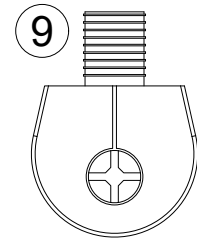
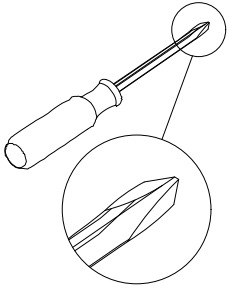

Turn clockwise to lock in place.

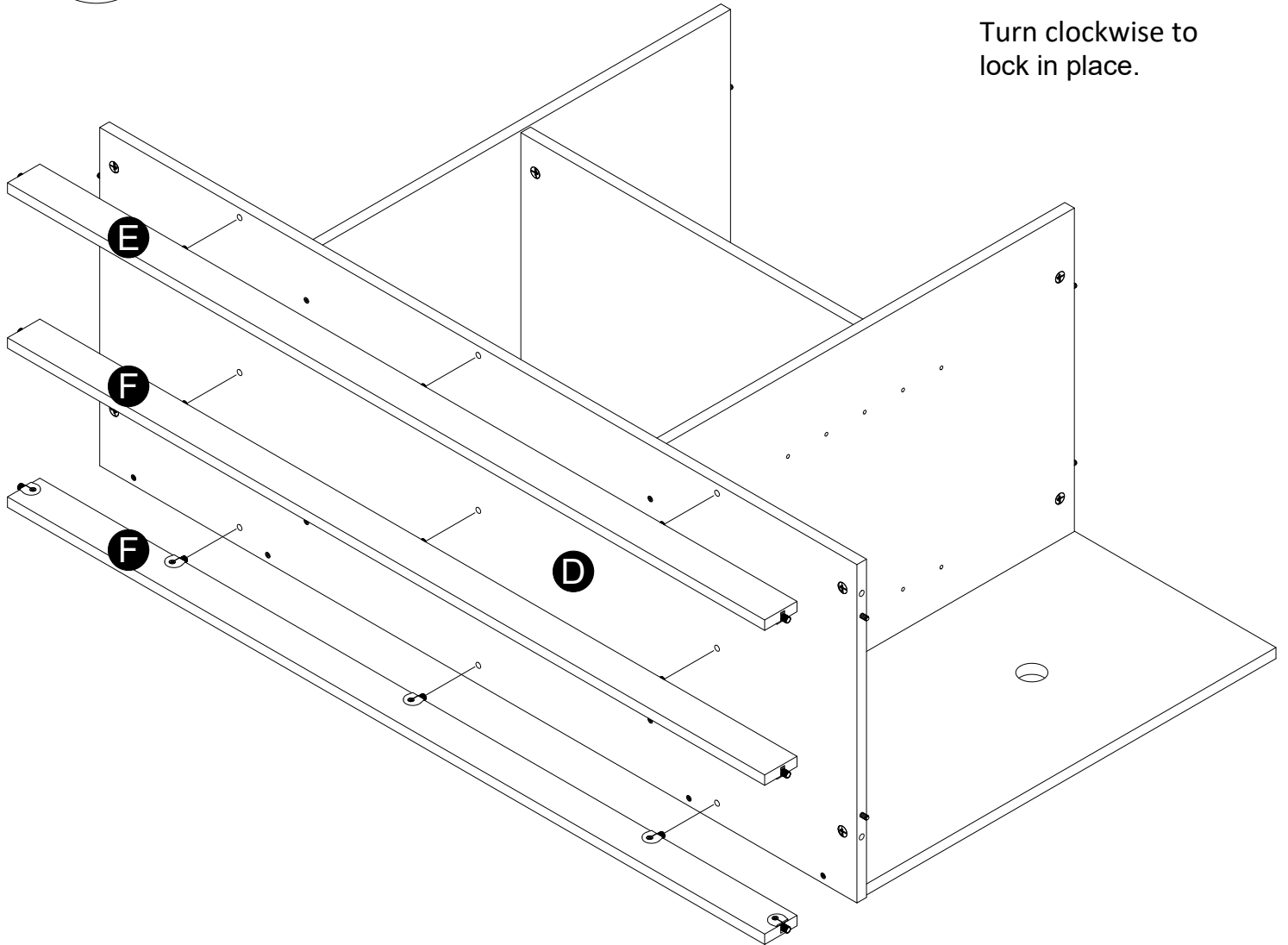

STEP 17

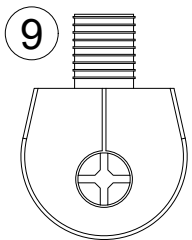
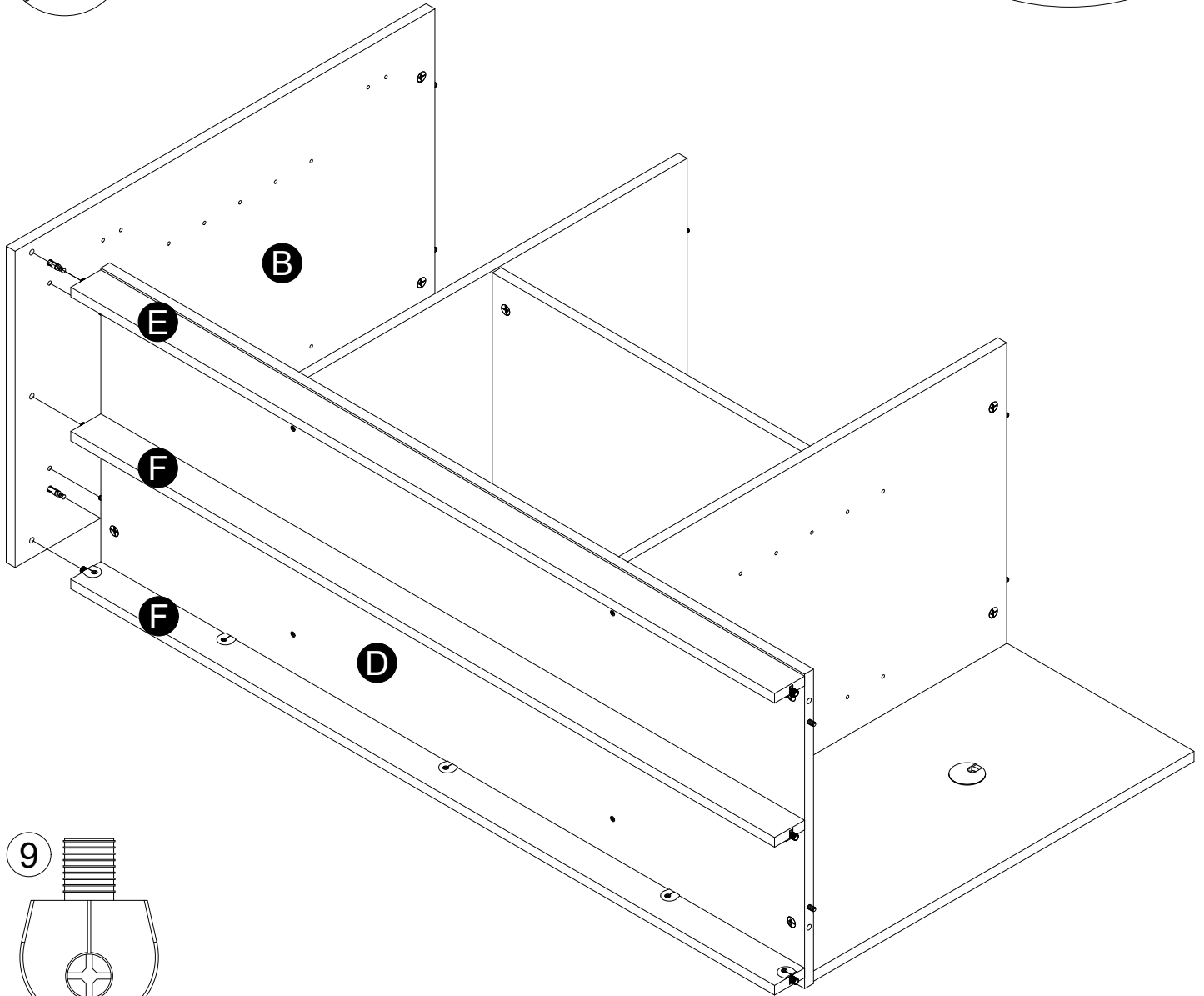
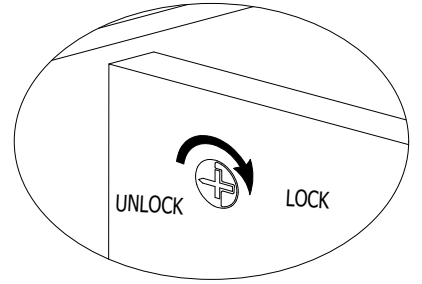
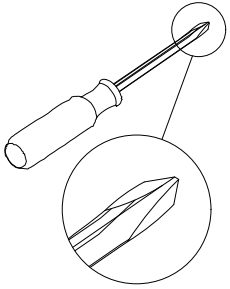

Turn clockwise to
lock in place.

STEP 18

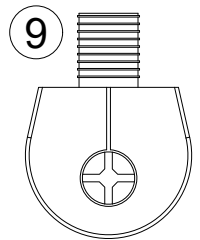
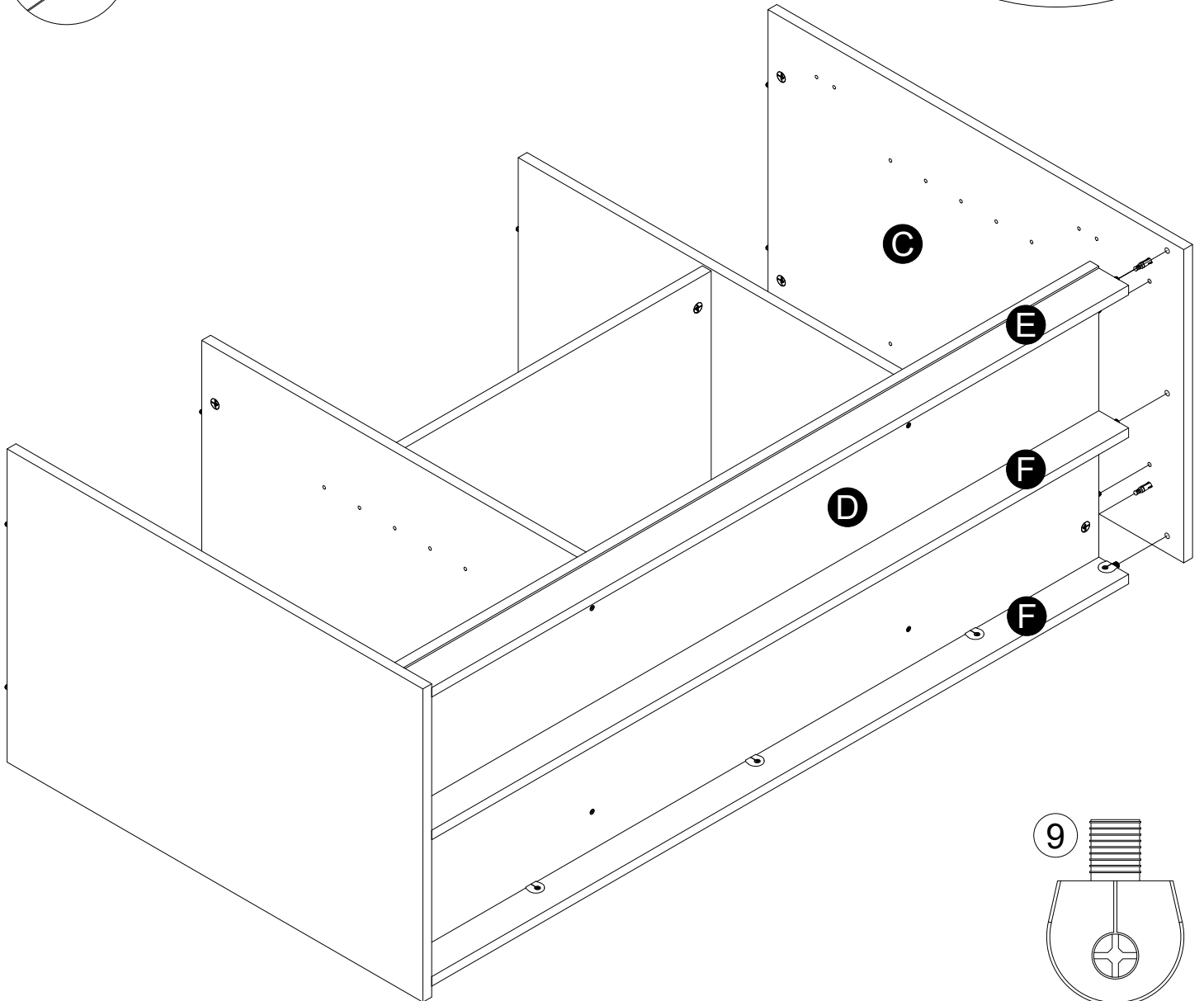
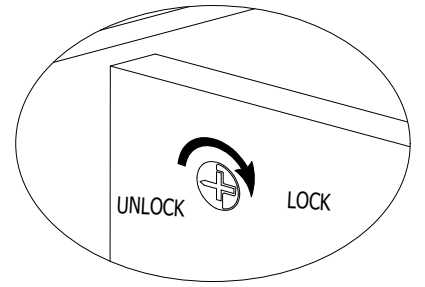
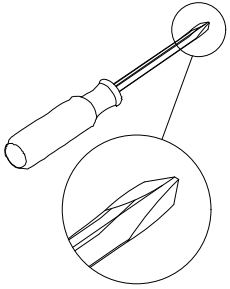

Turn clockwise to lock in place.

STEP 19

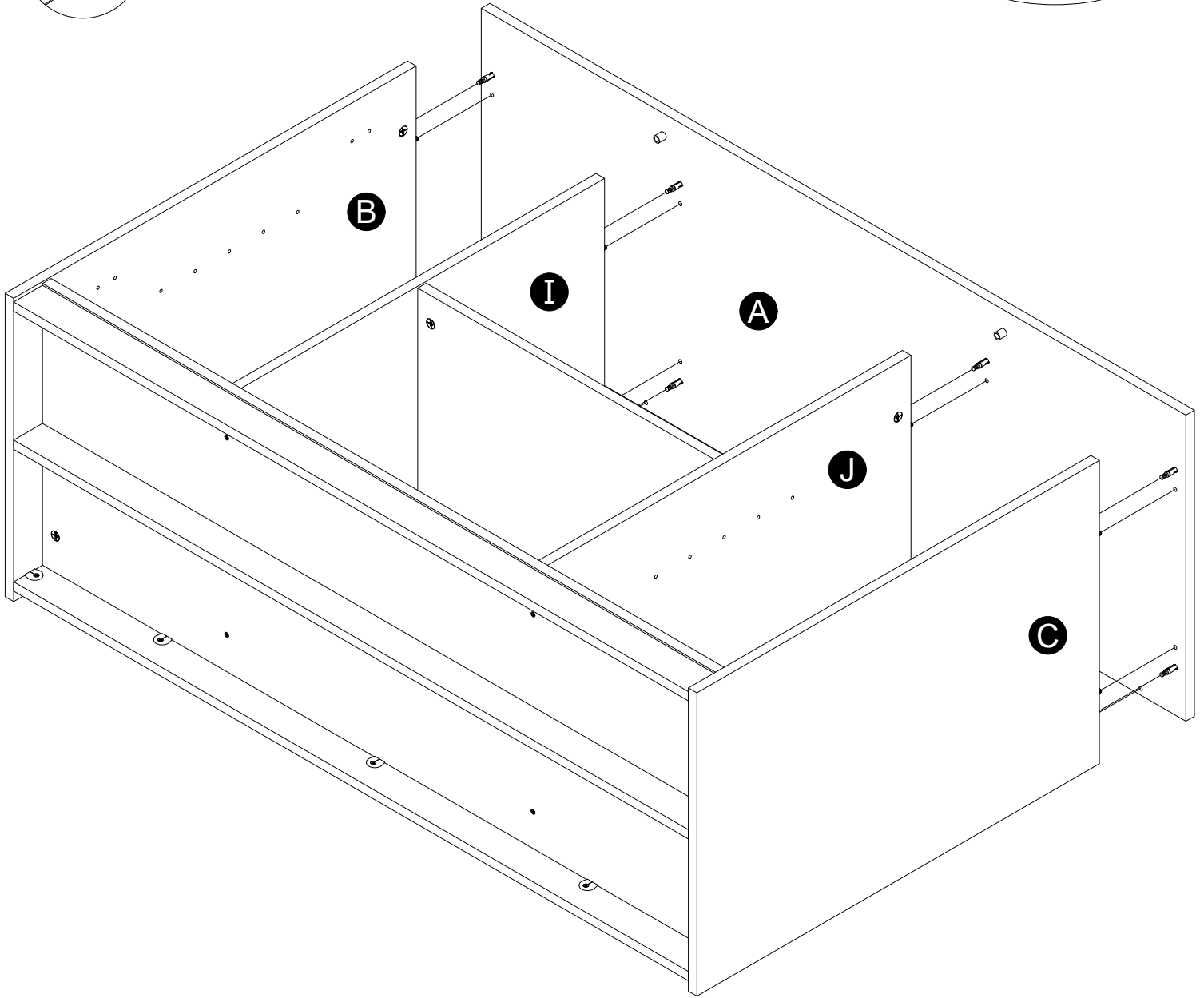
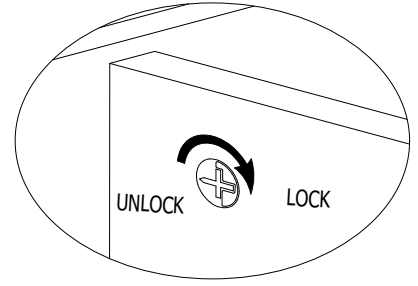
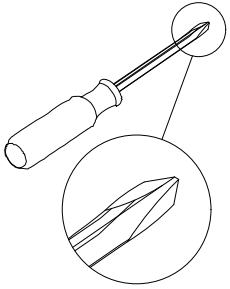

STEP 20

Carefully stand your unit upright as shown.

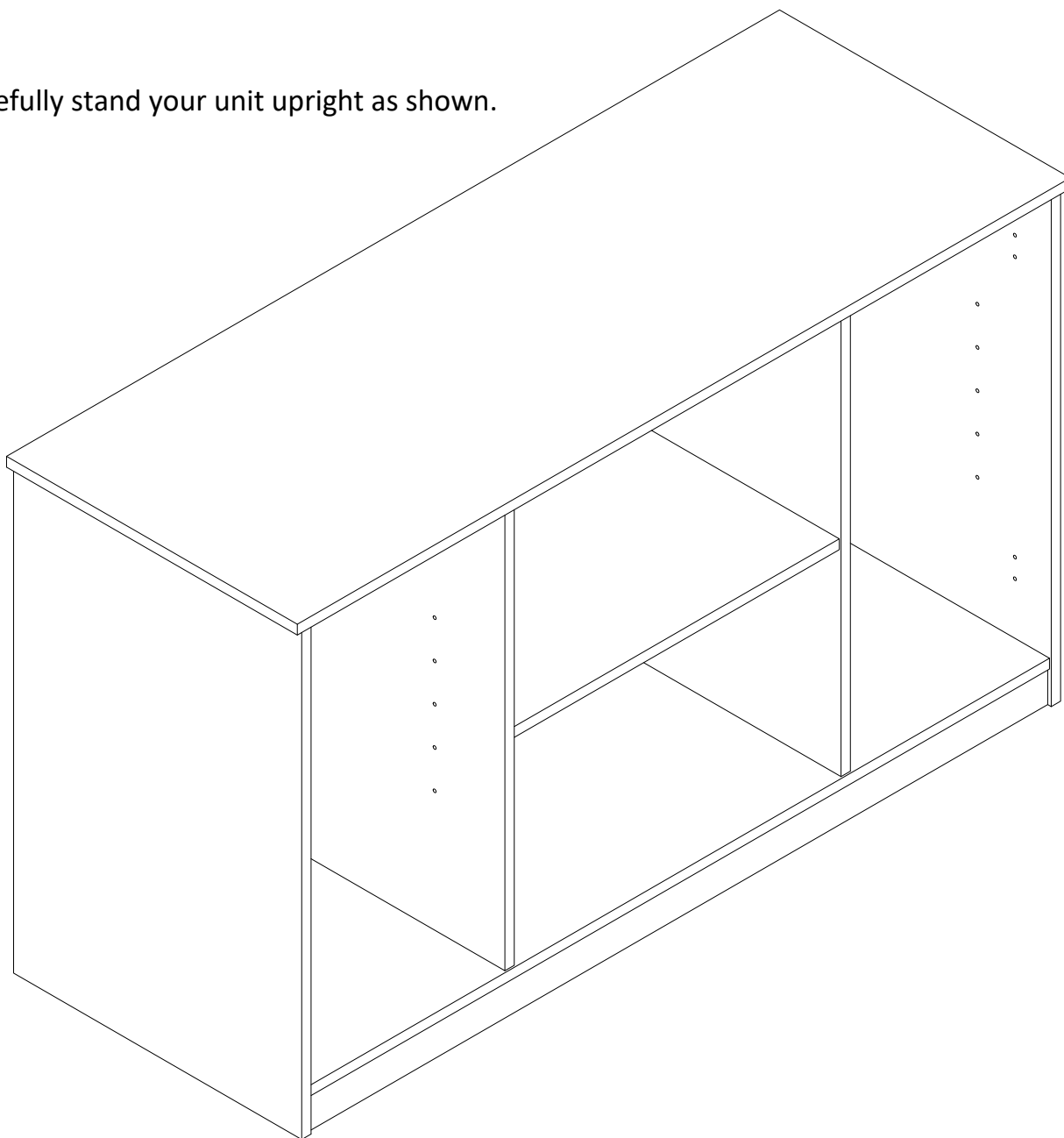

STEP 21

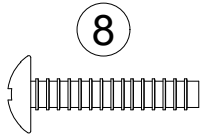
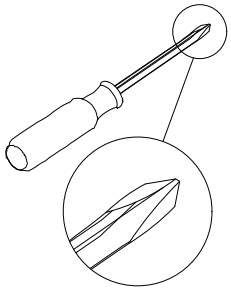

(x4)

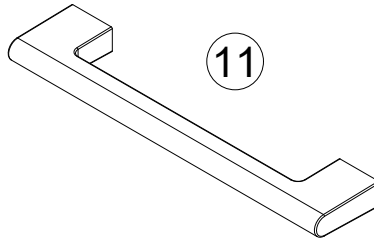

(x2)

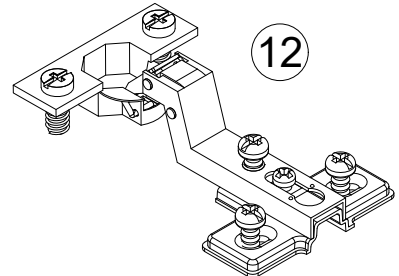

(x4)

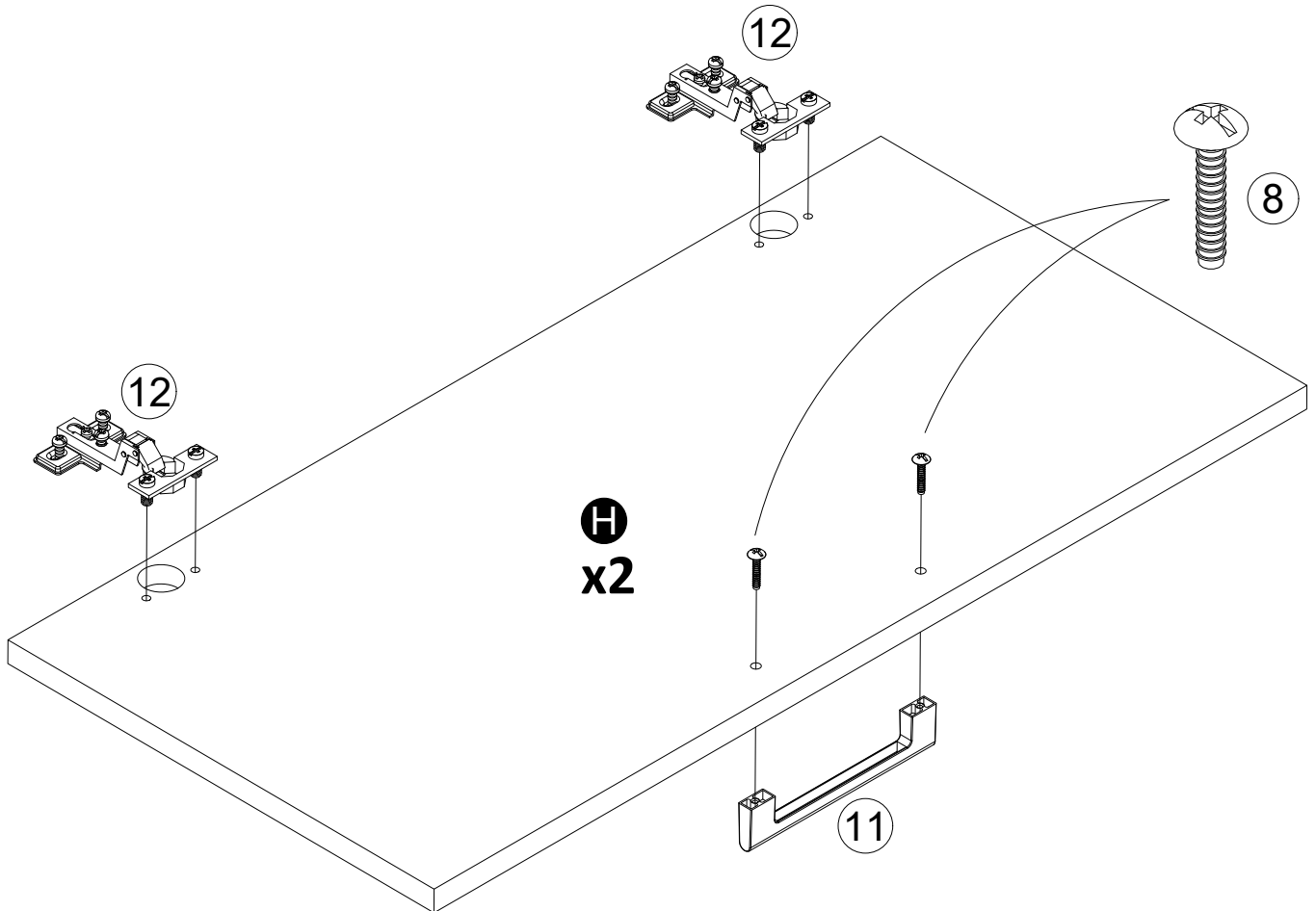

STEP 22

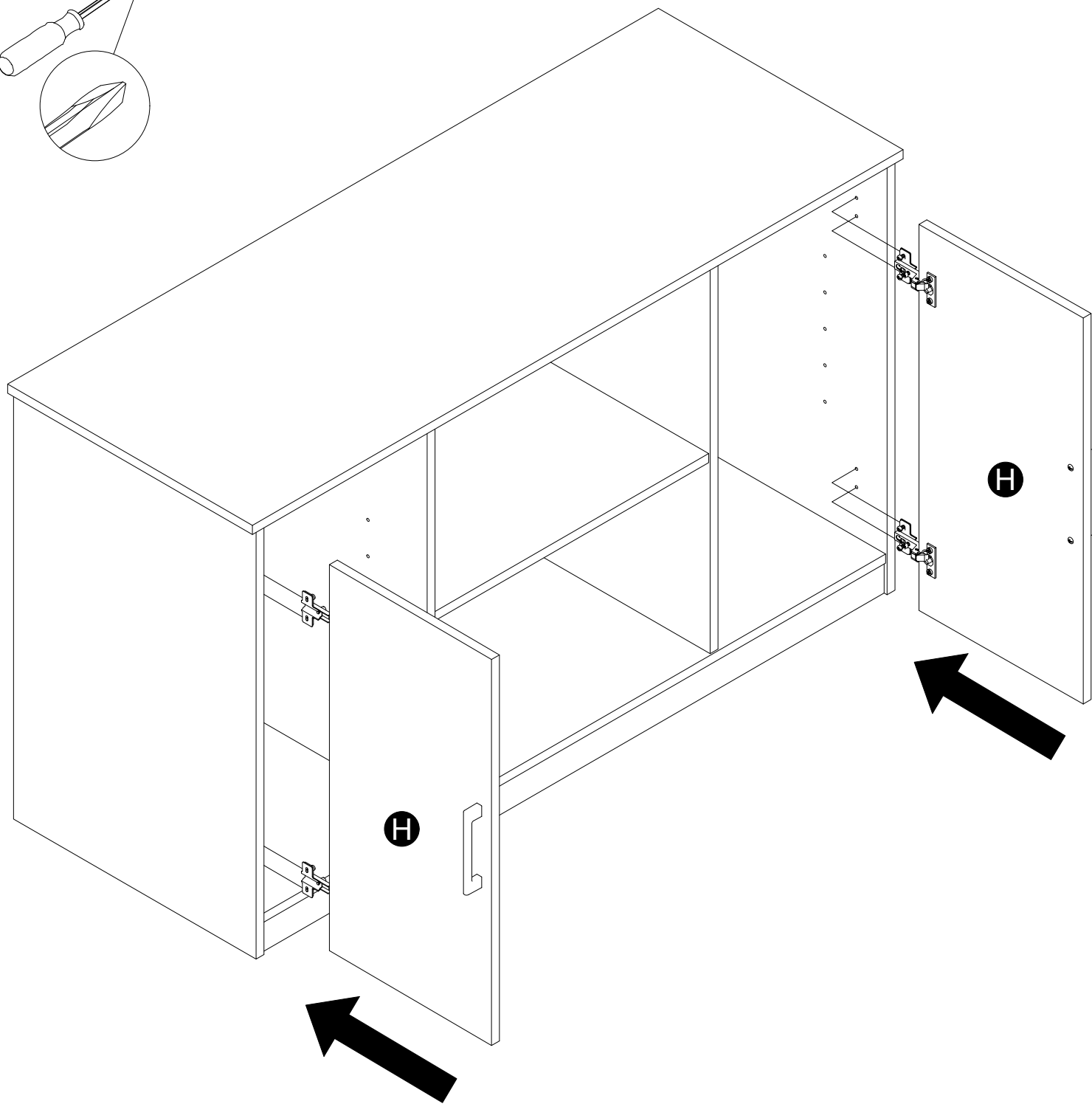
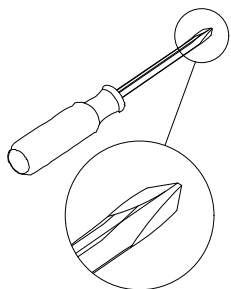

STEP 23

Door Adjustment

To adjust the vertical height:
Loosen the screws "A" on both hinges. They are usually in slotted holes which allows you to adjust up or down by a few mm. Then tighten back up.

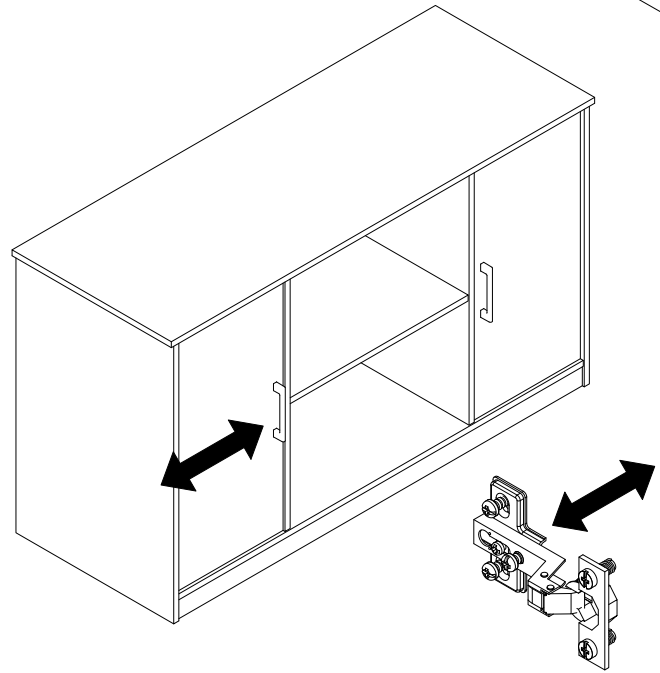
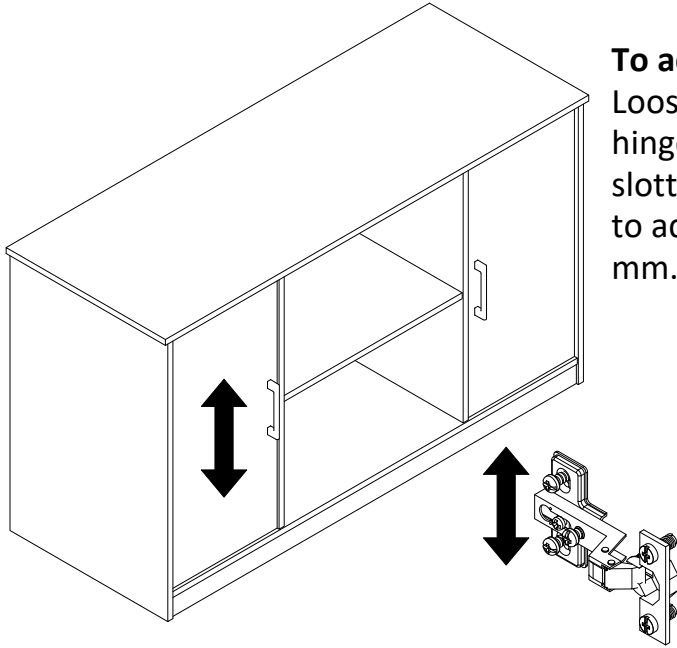
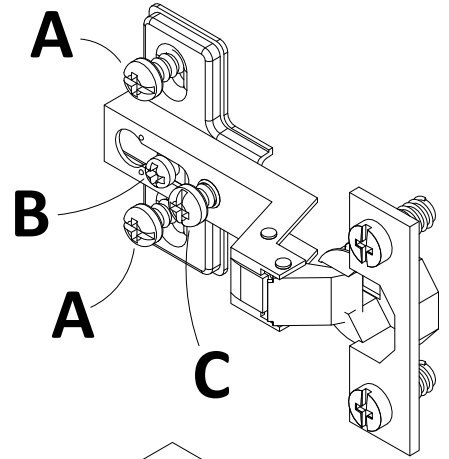

To adjust side to side:
Loosen the screw "C" on BOTH hinges and tighten "B" moves door outward. Loosen "B" and tighten "C" moves doors inward.

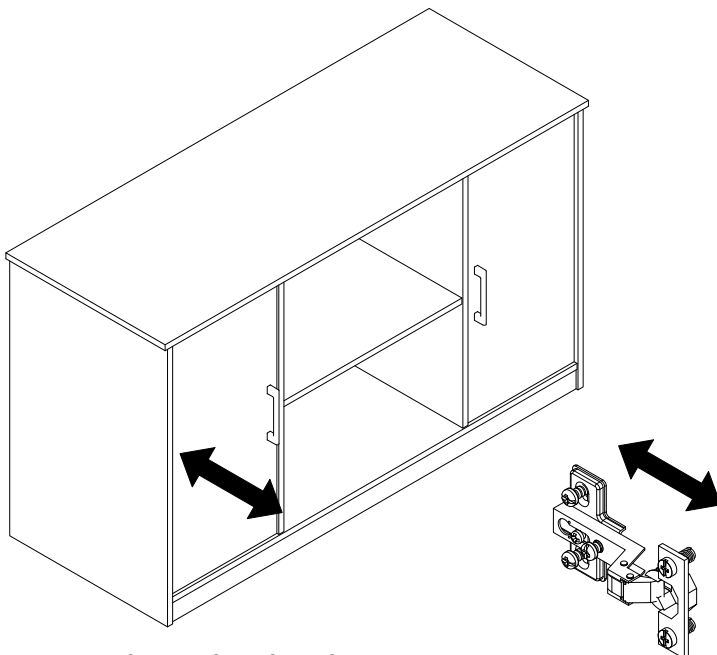

To adjust the depth:
Loosen the screw "B" and adjust door.

STEP 24

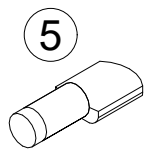

(x8)

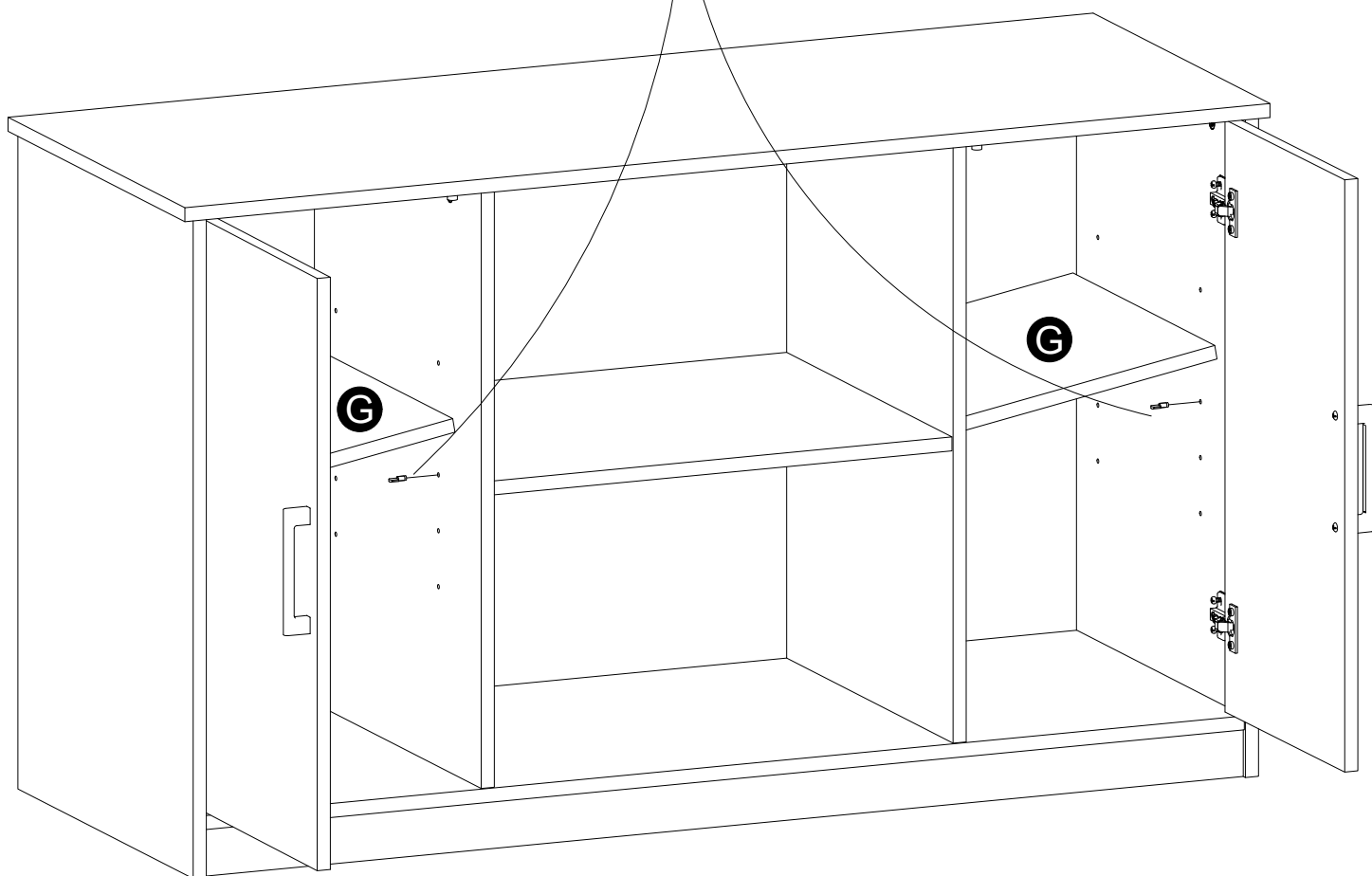
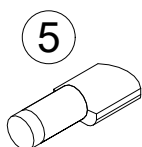

Maximum Loads

This unit has been designed to support the maximum loads shown. Exceeding these load limits could cause sagging, instability, product collapse, and/or serious injury.

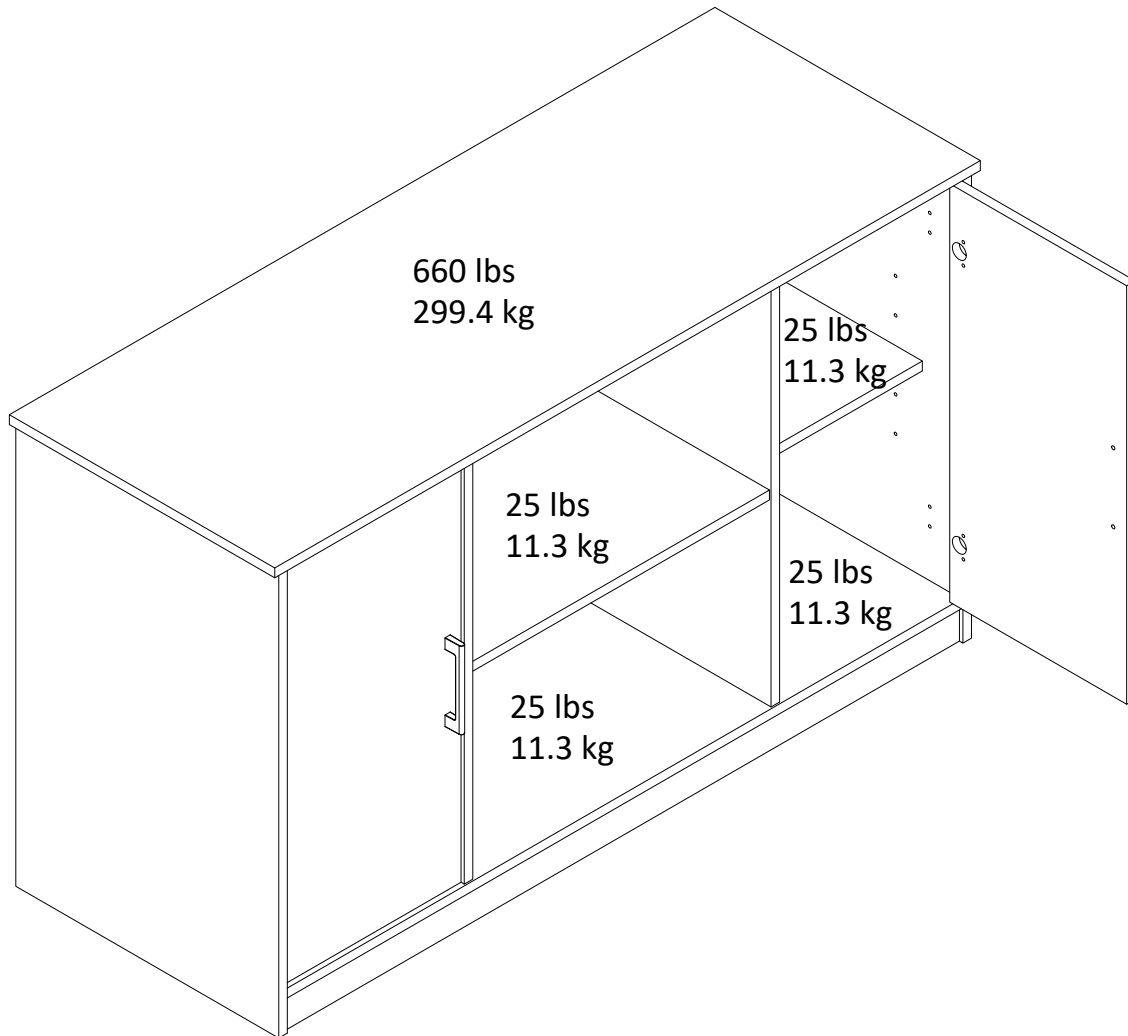

Warning: Risk of injury to persons - do not place a television on this furniture. This furniture is not approved for use with a television.

Certificate of Conformity

1. This certificate applies to the Dorel Home Furnishings, Inc. product identified by this instruction manual.
2. This certificate applies to compliance of this product with the CPSC Ban on Lead-Containing Paint (16 CFR 1303).
3. This product is distributed by: Dorel Home Furnishings, Inc.
410 East First Street South
Wright City, MO 63390
636-745-3351
4. Site of Manufacture: Cornwall, ON
5. See front page of instruction manual for date of manufacture.

Register your product to receive the following:



- * New trend details - sneak peek on what's new
- * Surveys - have a voice within our community
- * Exclusive deals and discount codes
- * Quick and easy replacement part service

To register your product, visit ameriwoodhome.com

5 Star Rating



Visit your local retailer's website, rate your purchased product and leave us some feedback!

We would like to extend a big "Thank You" to all of our customers for taking the time to assemble this Ameriwood Home product, and to give us your valuable feedback.

*Thank
You!*

Cubierta Delantera

Este libro de instrucciones contiene información **IMPORTANTE** de seguridad. Por favor lea y manténgalo para referencia en el futuro.

No Regrese este producto! Comuníquese con nuestro amigoso equipo de servicio al cliente para obtener ayuda.

Llámenos al: 1-800-489-3351 (Gratis)

Visitar: www.ameriwoodhome.com

PRECAUCION

Este mueble puede volcarse y causar graves heridas y/o muerte.

Anclar el mueble a un poste de madera en la pared (si esto se requiere).

No Permita que los niños monten el mueble.

Mantenga los artículos más pesados en los cajones de abajo.

Consejos Útiles (página 2)

- Abra su artículo en el área donde usted planea utilizarlo para evitar levantar y moverlo menos
- Identificar, ordenar y contar las piezas antes de intentar ensamblar
- Las clavijas de compresión se golpean con un martillo
- Las diapositivas están marcadas con una R (derecha) y L (izquierda) para la colocación correcta
- Asegúrese de que siempre este el punto localizado en la parte superior de bloqueador de leva este volteado hacia borde exterior
- Utilizar todos los clavos para el panel de atrás y distribuirlos por igual
- El panel de atrás debe utilizarse para asegurarse de que la unidad quede fija y firme
- No use químicas fuertes ni limpiadores abrasivos en este artículo
- Nunca empuje, tire ni arrastre los muebles

Antes de Que Empieces (página 3)

- Lea cuidadosamente cada paso y siga el orden correcto
- Separar y contar todas sus piezas y hardware
- Dése suficiente espacio para el proceso de ensamble
- Tenga las siguientes herramientas: destornillador de cabeza plana, #2 cabeza Phillips
Destornillador y martillo
- Precaución: Si usa un taladro electrónico o un destornillador eléctrico para atornillar, por favor asegúrese que deje de atornillar cuando el tornillo este apretado. Fallar hacer esto puede causar barrer el tornillo.

Sistema de fijar el bloqueo de leva (página 3)

Este sistema de fijar el bloqueo de leva sera usado en todo el proceso ensamble.

Página 4-Identificación del tablero

Tamaño no real

Arriba (A)
Lado izquierdo (B)
Lado derecho (C)
Parte inferior (D)
Patear (E)
Soporte inferior (F)
Estante ajustable (G)
Puerta (H)
Partición izquierda (I)
Tabique Derecho (J)
Repisa central (K)
Respaldo central (L)
Respaldo (M)

Paso 16

Gire en el sentido de las agujas del reloj para bloquear.

Paso 17

Gire en el sentido de las agujas del reloj para bloquear.

Paso 18

Gire en el sentido de las agujas del reloj para bloquear.

Paso 20

Coloque con cuidado la unidad en posición vertical, tal como se muestra.

Paso 23

Ajuste de la puerta

Para ajustar la altura vertical:

Afloje los tornillos "A" de ambas bisagras. Suelen estar en agujeros ranurados que le permiten ajustar unos mm hacia arriba o hacia abajo. Vuelva a apretarlos.

Para ajustar de lado a lado:

Afloje el tornillo "C" en AMBAS bisagras y apretando "B" mueve la puerta hacia afuera. Aflojar "B" y apretando "C" mueve las puertas hacia adentro.

Para ajustar la profundidad:

Afloje el tornillo "B" y ajuste la puerta.

Página 6-Lista de piezas

Tamaño real

Cierre de leva (1)
perno de leva (2)
Pasador de madera (3)
Tornillo Confirmat (4)
Soporte de estante (5)
Tornillo de cabeza plana #6x5/8 (6)
Pasador de soporte (7)
Perno 7/8 (8)

Cierre rápido (9)

Tamaño no real

Ojal con tapa (10)
Asa (11)
Bisagra (12)

Página 31- **weight limit page**

CARGA MAXIMA

Esta unidad ha sido diseñada para soportar la carga máxima anotada. El exceder estos límites puede causar inestabilidad, colapsarse y/o causar serias lesiones.

ADVERTENCIA: Riesgo de lesiones a las personas - no coloque un televisor sobre muebles. Este mueble no está aprobado para su uso con un televisor.

Página 32

Registre su producto para recibir lo siguiente:

- * Detalles de nuevas tendencias - Vistazo a lo nuevo
- * Encuestas - alec su voz entre su comunidad
- * Códigos de ofertas y descuentos exclusivos
- * Fácil y rápido servicio de partes de remplace

Para registrar su producto, visite ameriwoodhome.com

Clasificación de 5 estrellas

Visite el sitio web de su tienda local, califique su comprado y denos sus comentarios!

Nos gustaría enviar un gran "Agradecimiento" a todos nuestros clientes por tomarse el tiempo de ensamblar este producto de Ameriwood Home, y por darnos sus valiosos comentarios.

Gracias

Couverture Avant

CE LIVRET D'INSTRUCTION CONTIENT DES INFORMATIONS **IMPORTANTES** SUR LA SÉCURITÉ. VEUILLEZ LIRE ET GARDER POUR UNE RÉFÉRENCE FUTURE

Ne retournez pas ce produit! Contactez notre équipe de service à la clientèle amicale d'abord pour obtenir de l'aide.

Appelez-nous: 1-800-489-3351 (sans frais)

Visitez: www.ameriwoodhome.com

ATTENTION

Le meuble peut basculer et causer des blessures graves ou la mort.

Ancrer le meuble à une planche murale dans le mur (si indiqué).

Ne laissez pas les enfants grimper sur le meuble.

Placez les articles lourds sur les étagères ou dans les tiroirs inférieurs.

Astuces Utiles (page 2)

-Ouvrez votre article dans la zone que vous prévoyez de le garder pour moins de levage lourd

-Identifier, trier et compter les pièces avant d'essayer d'assembler

-Les goujons de compression sont taraudés avec un Marteau

-Les glissières sont marquées d'un R (droit) et d'un L (gauche) pour un bon placement

-Assurez-vous toujours de faire face la pointe situé sur le haut de la Serrure de Came vers le bord extérieur

-Utiliser tous les clous fournis pour le panneau arrière et les répartir également

-Le panneau arrière doit être utilisé pour vous assurer que votre appareil est robuste

-N'utilisez pas de produits chimiques agressifs ou de nettoyeurs abrasifs sur cet appareil

-Ne jamais pousser, tirer, ou faire glisser votre meuble

Avant de Commencer (page 3)

-Lisez attentivement chaque étape et suivez le bon ordre

-Séparez et comptez toutes vos pièces et matériaux

-Donnez-vous suffisamment de place pour l'assemblage

-Avoir les outils suivants: tournevis à tête plate, #2 tournevis Phillips, et Marteau

-Attention: Si vous utilisez une perceuse électrique ou un tournevis électrique pour visser, veillez à ralentir et arrêter lorsque la vis est bien serrée. Le non-respect de cette consigne peut endommager la vis.

Système de Fixation de Came (page 3)

Ce Système de Fixation de Came sera utilisé tout au long de l'assemblage

Étape 4-Identification du panneau

Pas la taille réelle

Haut (A)
Côté gauche (B)
Côté droit (C)
Bas (D)
Garde-pieds (E)
Support inférieur (F)
Étagère réglable (G)
Porte (H)
Partition gauche (I)
Partition droite (J)
Étagère intermédiaire (K)
Milieu du panneau arrière (L)
Panneau arrière (M)

Étape 6-Liste des pièces

Taille réelle

Serrure batteuse (1)
boulon à came (2)
Cheville en bois (3)
Vis d'assemblage Confirmat (4)
Support d'étagère (5)
Vis à tête bombée #6x5/8 po (6)
Attache de soutien (7)
Boulon 7/8 po (8)
Verrouillage rapide (9)

Pas la taille réelle

Passe-fil avec capuchon (10)
Poignée (11)
Charnière (12)

Étape 16

Tournez dans le sens des aiguilles d'une montre pour verrouiller en place.

Étape 17

Tournez dans le sens des aiguilles d'une montre pour verrouiller en place.

Étape 18

Tournez dans le sens des aiguilles d'une montre pour verrouiller en place.

Étape 20

Redressez soigneusement votre unité comme illustré.

Étape 23

Ajustement de la porte

Pour régler la hauteur verticale :

Desserrez la vis « A » sur les deux charnières. Ils sont généralement situés dans des trous oblongs qui vous permettent de les ajuster vers le haut ou vers le bas de quelques millimètres, puis resserrez.

Pour ajuster d'un côté à l'autre :

Desserrez la vis « C » sur les DEUX charnières et serrez « B » pour déplacer la porte vers l'extérieur. Desserrez « B » et serrez « C » pour ajuster les portes vers l'intérieur.

Pour régler la profondeur :

Desserrez la vis « B » et ajustez la porte.

Étape 31 - **weight limit step**

CHARGES MAXIMALES

Ce meuble a été conçu pour supporter les charges maximales indiquées. En excédant ces limites de charge, le meuble pourrait devenir instable, s'effondrer, et/ou causer des blessures graves.

AVERTISSEMENT : Risque de blessure corporelle - ne pas placer une télévision sur ce meuble. Ce meuble n'est pas approuvé pour une utilisation avec une télévision.

Étape 32

Enregistrez votre produit pour recevoir les éléments suivantes:

- * Détails sur les nouvelles tendances - un aperçu sur les nouveautés
- * Sondages - avoir une voix au sein de notre communauté
- * Offres exclusives et codes promo
- * Service de pièces de rechange rapide et facile

Pour enregistrer votre produit, visitez ameriwoodhome.com

5 Étoiles

Visitez le site Web de votre détaillant local, évaluez votre produit acheté et laissez-nous quelques commentaires !

Nous tenons à offrir un grand "Merci" à tous nos clients pour avoir pris le temps d'assembler ce produit "Ameriwood Home", et de nous donner vos commentaires précieux.

Merci