

9262335COM Aquarium Stand 55 Gallon

Ameriwood
HOME

Date of Purchase ___ / ___ / ___
Lot Number:

B349262335COM

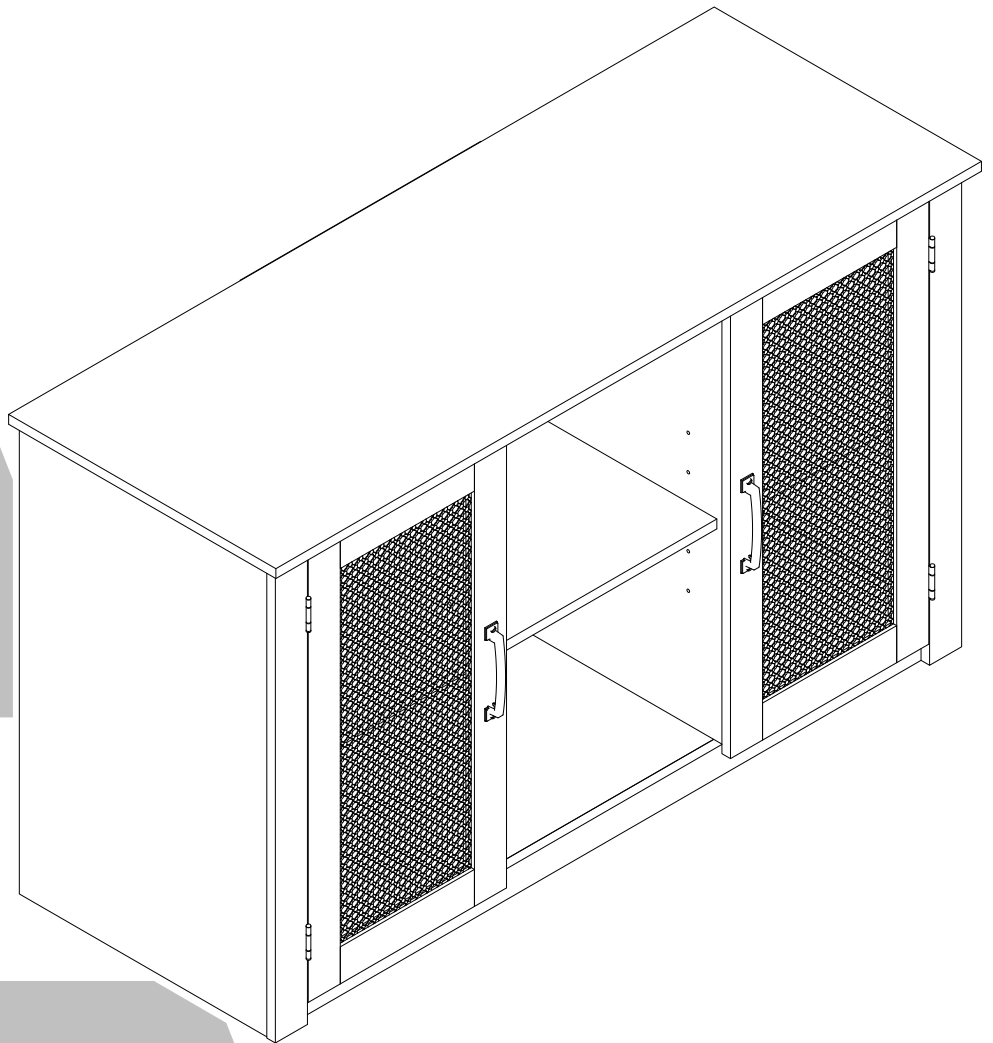

THIS INSTRUCTION BOOKLET CONTAINS **IMPORTANT** SAFETY INFORMATION. PLEASE READ AND KEEP FOR FUTURE REFERENCE.

Do Not Return This Product!

Contact our customer service team for help first.

Call: 1-800-489-3351 (toll free)

Visit: www.ameriwoodhome.com



WARNING

- Unit can tip over causing severe injury or death.
- Anchor unit to stud in wall (if instructed to).
- Do Not allow children to climb on unit.
- Put heavy items on lower shelves or drawers.

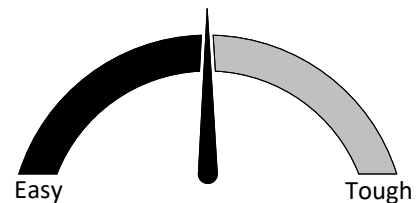

Assembly Difficulty Meter

Follow Ameriwood Home



Contact Us!

Do NOT return this product!

Contact our friendly customer service team first for help.

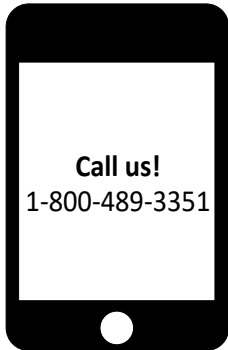

Visit ameriwoodhome.com to view the limited warranty valid in the U.S. and Canada.

Assembly Tips



Helpful Hints

PEOPLE NEEDED FOR ASSEMBLY: 1-2

- Open your item in the area you plan to keep it to avoid excessive heavy lifting.
- Identify, sort and count the parts before attempting assembly.
- Compression dowels are lightly tapped in with a hammer.
- Make sure to always face the point on the top of the Cam Lock towards the outer edge.
- Use all the nails provided for the back panel and spread them out equally.
- Back panel must be used to make sure your unit is sturdy.
- Do NOT use harsh chemicals or abrasive cleaners on this item.
- Never push, pull, or drag your furniture.

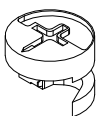
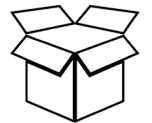

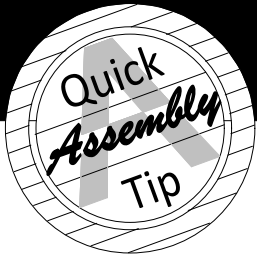

Before You Start

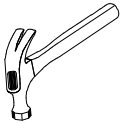
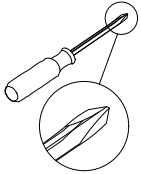

- ✓ Read through each step carefully and follow the proper order
- ✓ Separate and count all your parts and hardware
Parts are labeled on the surface or edge of the part
- ✓ Give yourself enough room for the assembly process
- ✓ Have the following tools: #2 Phillips Head Screwdriver and Hammer
- ✓ Caution: If using a power drill or power screwdriver for screwing, please be aware to slow down and stop when screw is tight. Reduce torque setting to a lower level so the drill will skip when the screw is tight. Failure to do so may result in stripping the screw.

Cam Lock Fastening System

This Cam Lock Fastening System will be used throughout the assembly process.

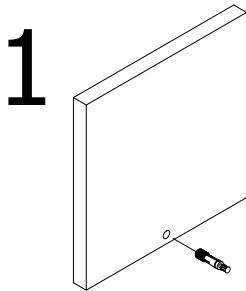

1 Press CAM BOLT into hole.

2

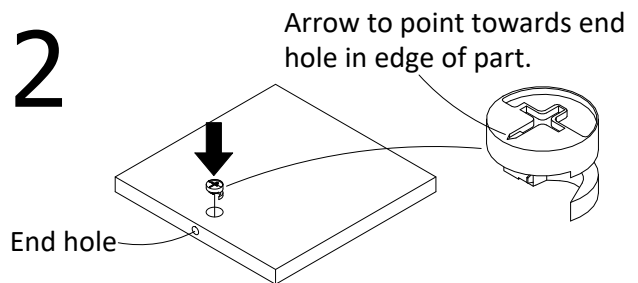

End hole
Press CAM LOCK into hole.

3

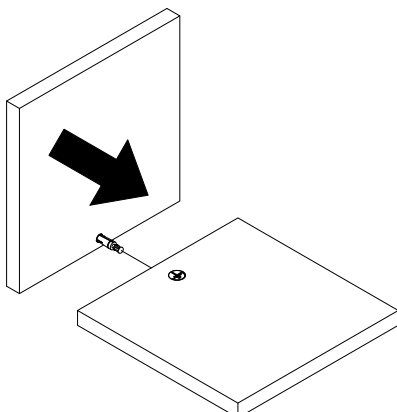

Press parts together so CAM BOLT inserts into edge hole.

4

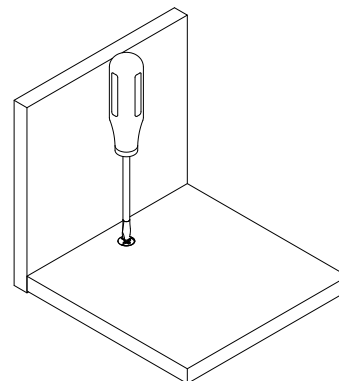

Using a screwdriver, turn the CAM LOCK clockwise to lock the CAM LOCK and CAM BOLT into their holes and fastening parts together.

Board Identification

Not actual size

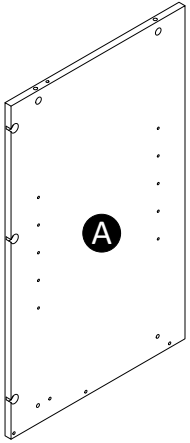

Left Panel
39262335010

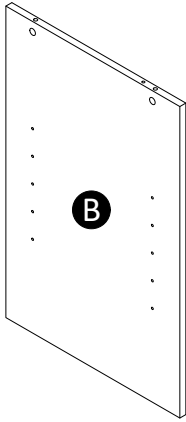

Left Partition
39262335020

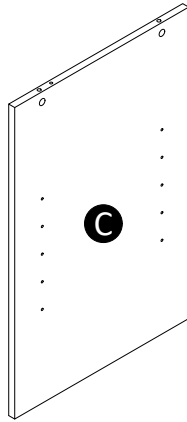

Right Partition
39262335030

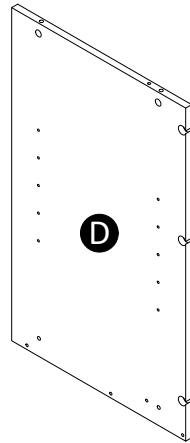

Right Panel
39262335040

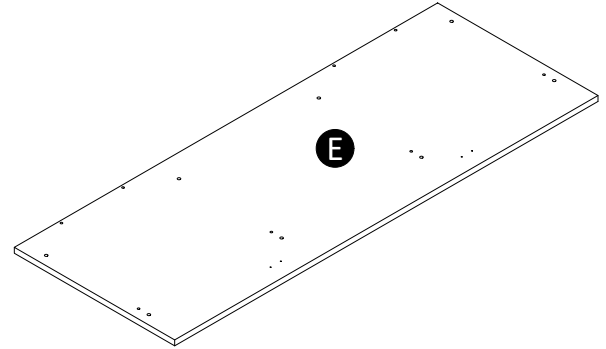

Top
39262335050

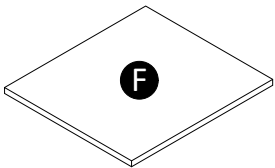

x2
Adj Shelf
39262335060

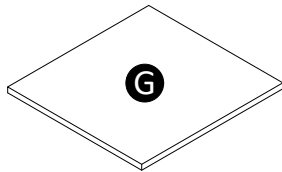

Center Adj Shelf
39262335070

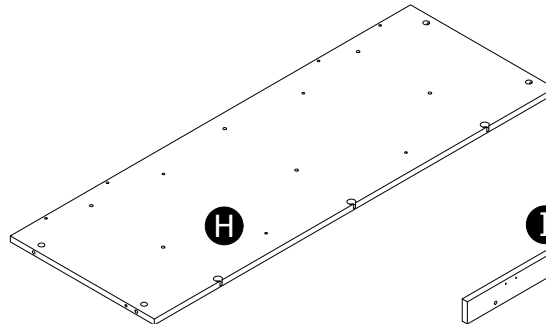

Bottom
39262335080

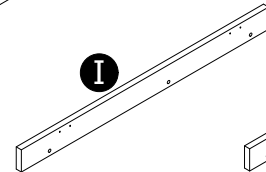

Left
Vertical Molding
39262335090

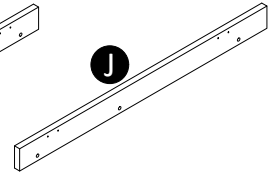

Right
Vertical Molding
39262335100

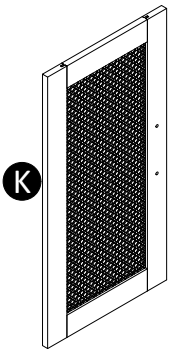

x2
Door
39262335110

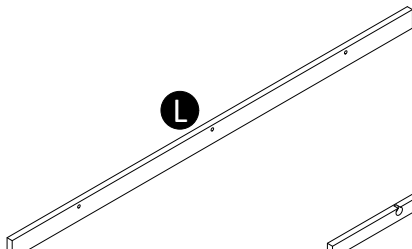

Kick
39262335120

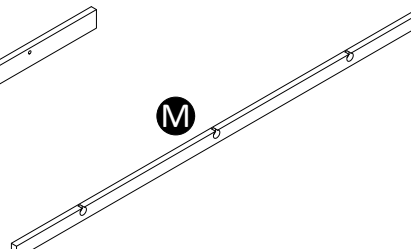

x2
Support
39262000130

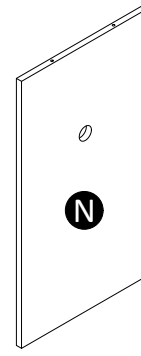

x2
Back Panel
39262335140

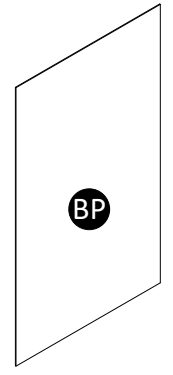

Center Back Panel
K926233500

Board Identification

Not actual size

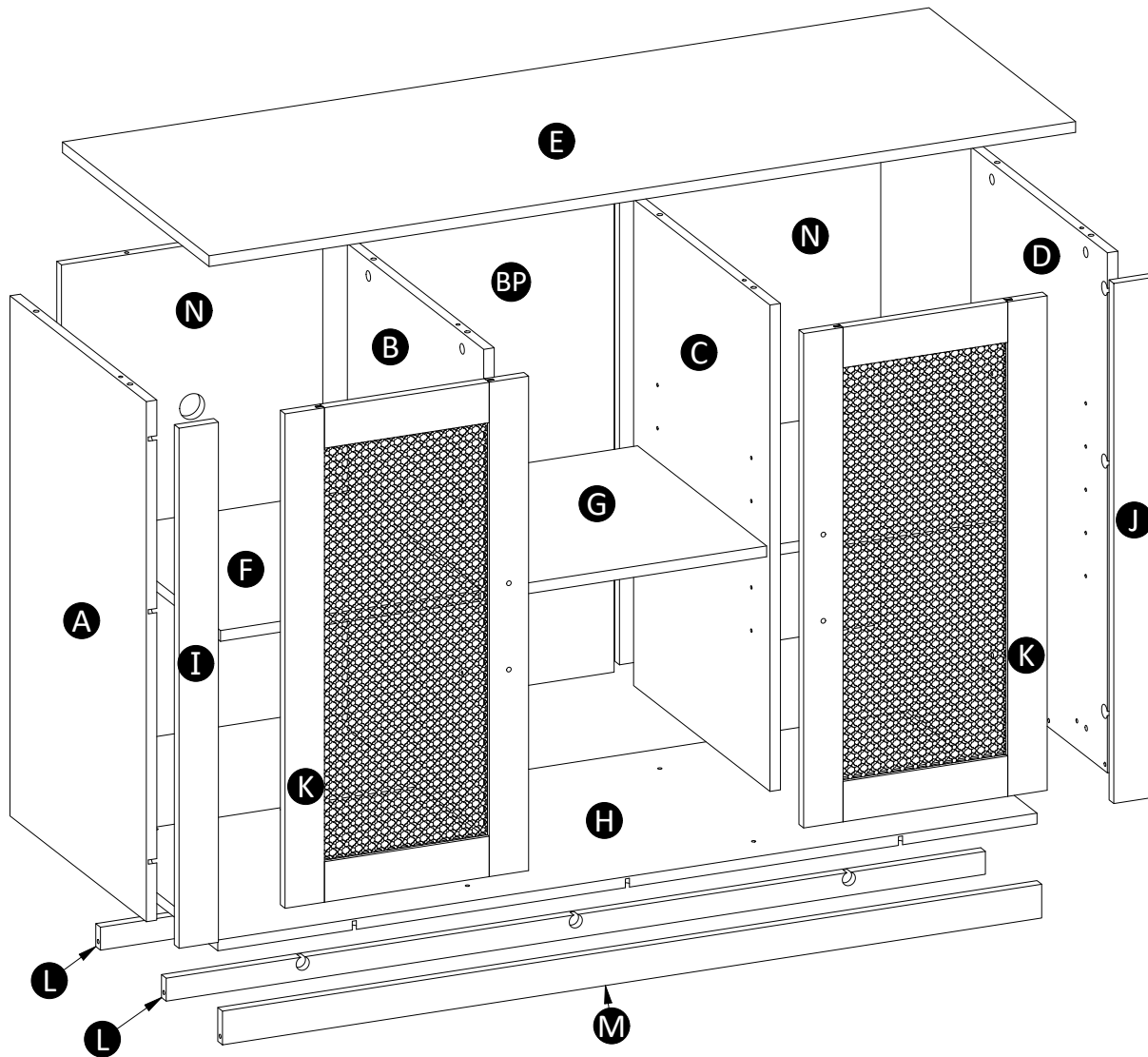

Part List

Actual Size

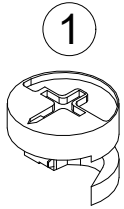

(x12)
#A22700
cam lock

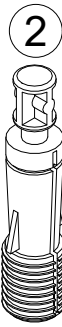

(x12)
#A22710
cam bolt

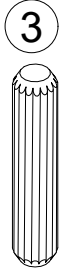

(x16)
#A21670
dowel

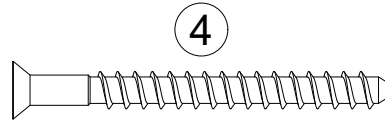

(x8)
#A23030
confirmat srew

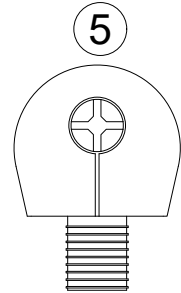

(x15)
#A22760
quicklock

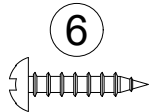

(x16)
#A11170
5/8" screw

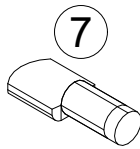

(x12)
#A80250
shelf support

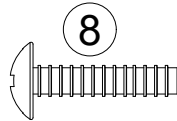

(x4)
#A17300
bolt

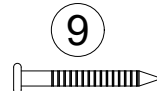

(x12)
#A2110
nail

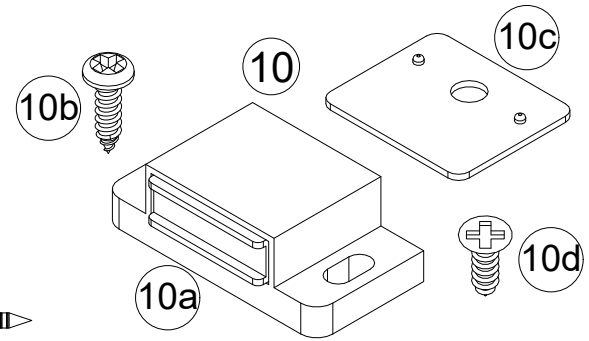

(x2)
#A31000
magnetic catch kit

Not Actual Size

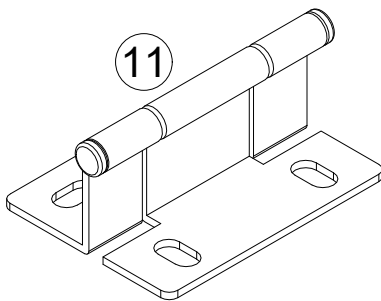

(x4)
#A60110
hinge

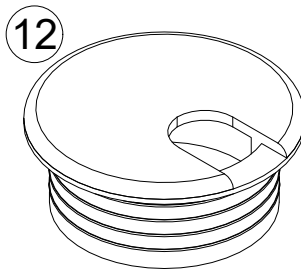

(x2)
#A70310
grommet

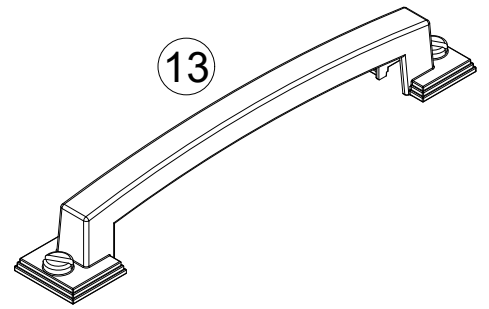

(x2)
#A50875
handle

STEP 1

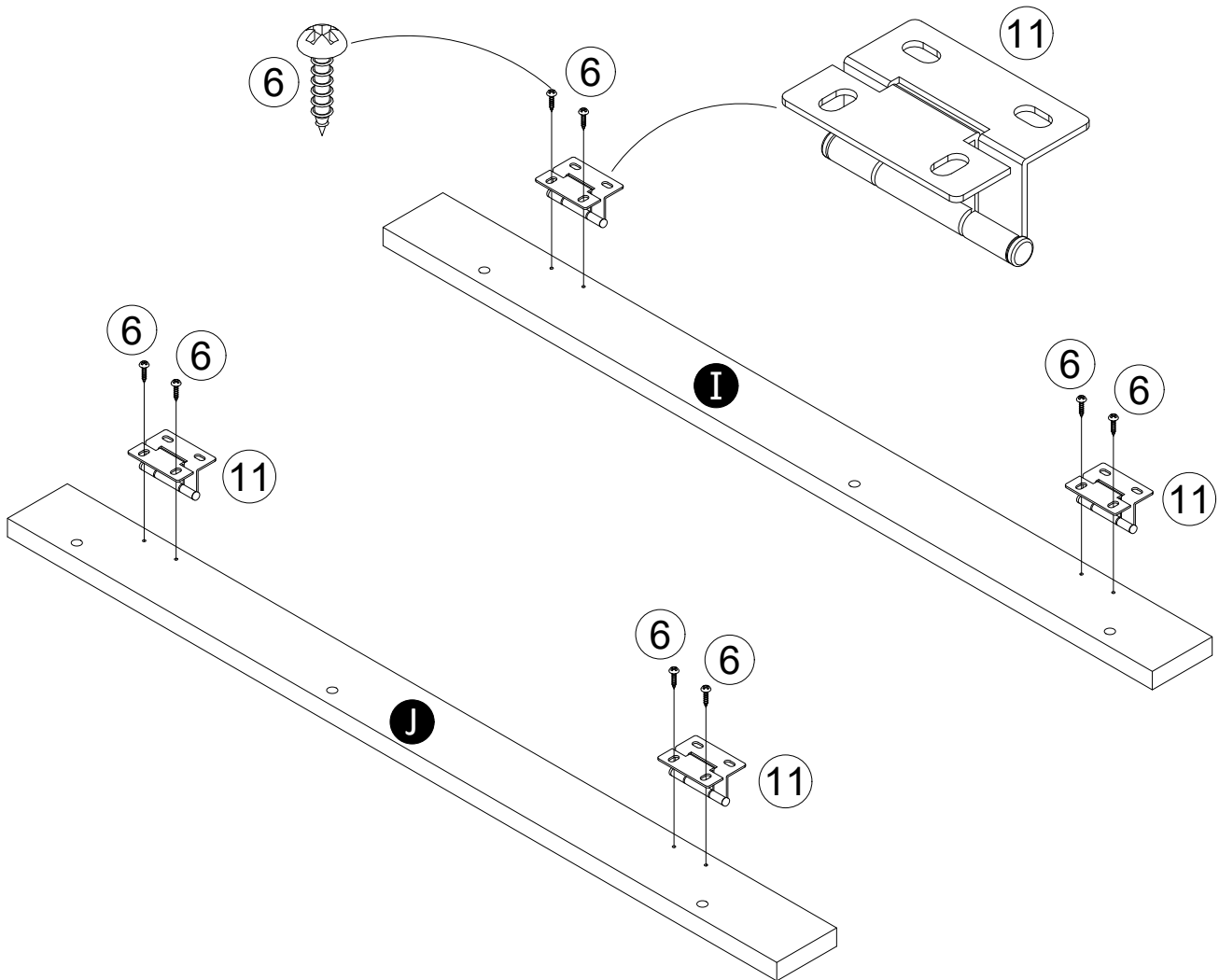
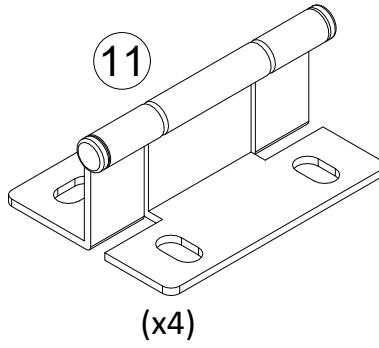
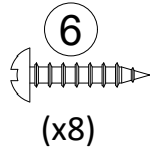
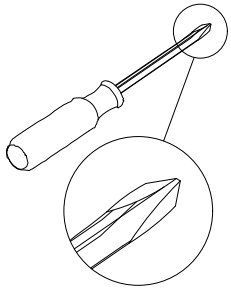

STEP 2

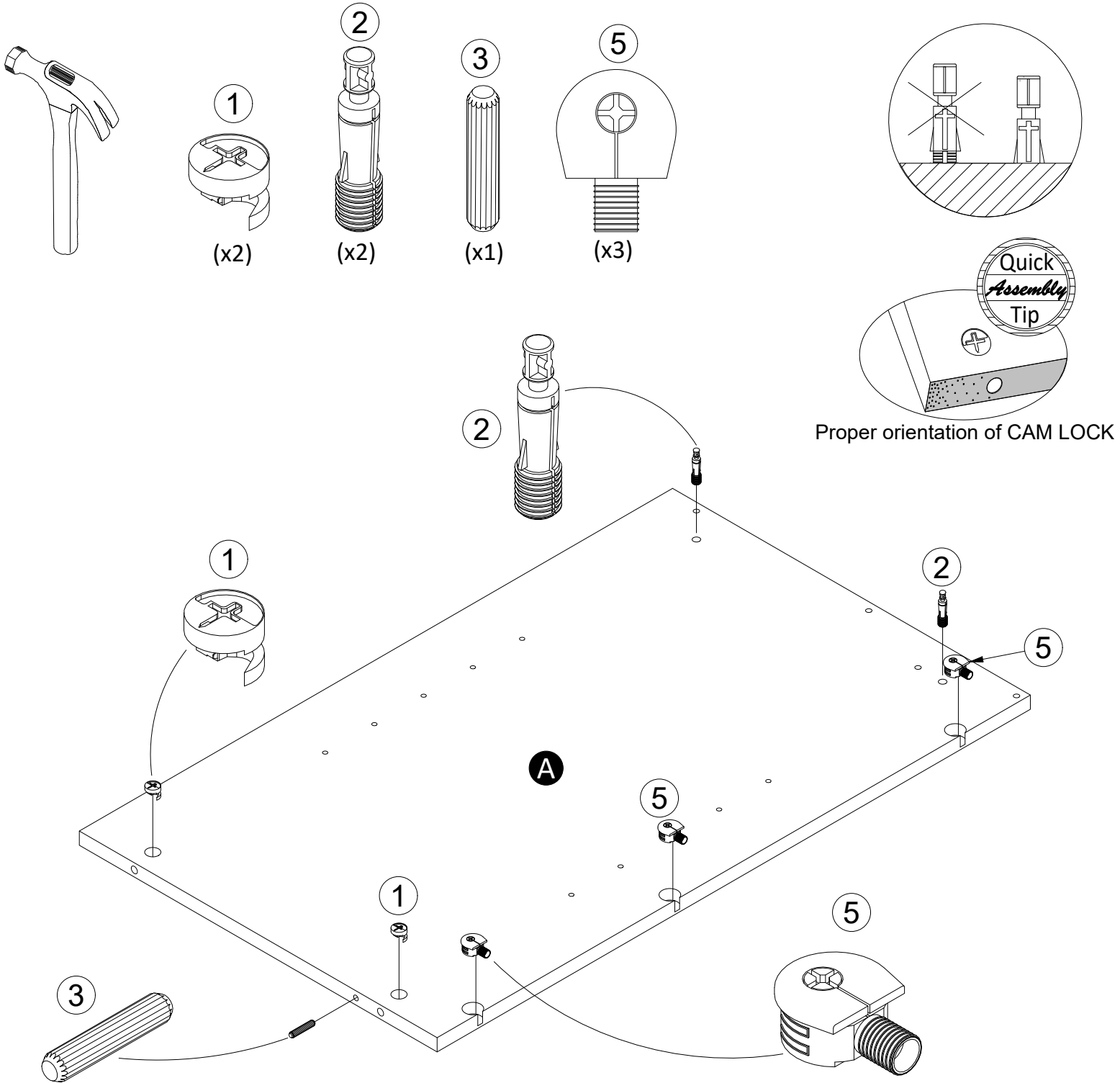

STEP 3

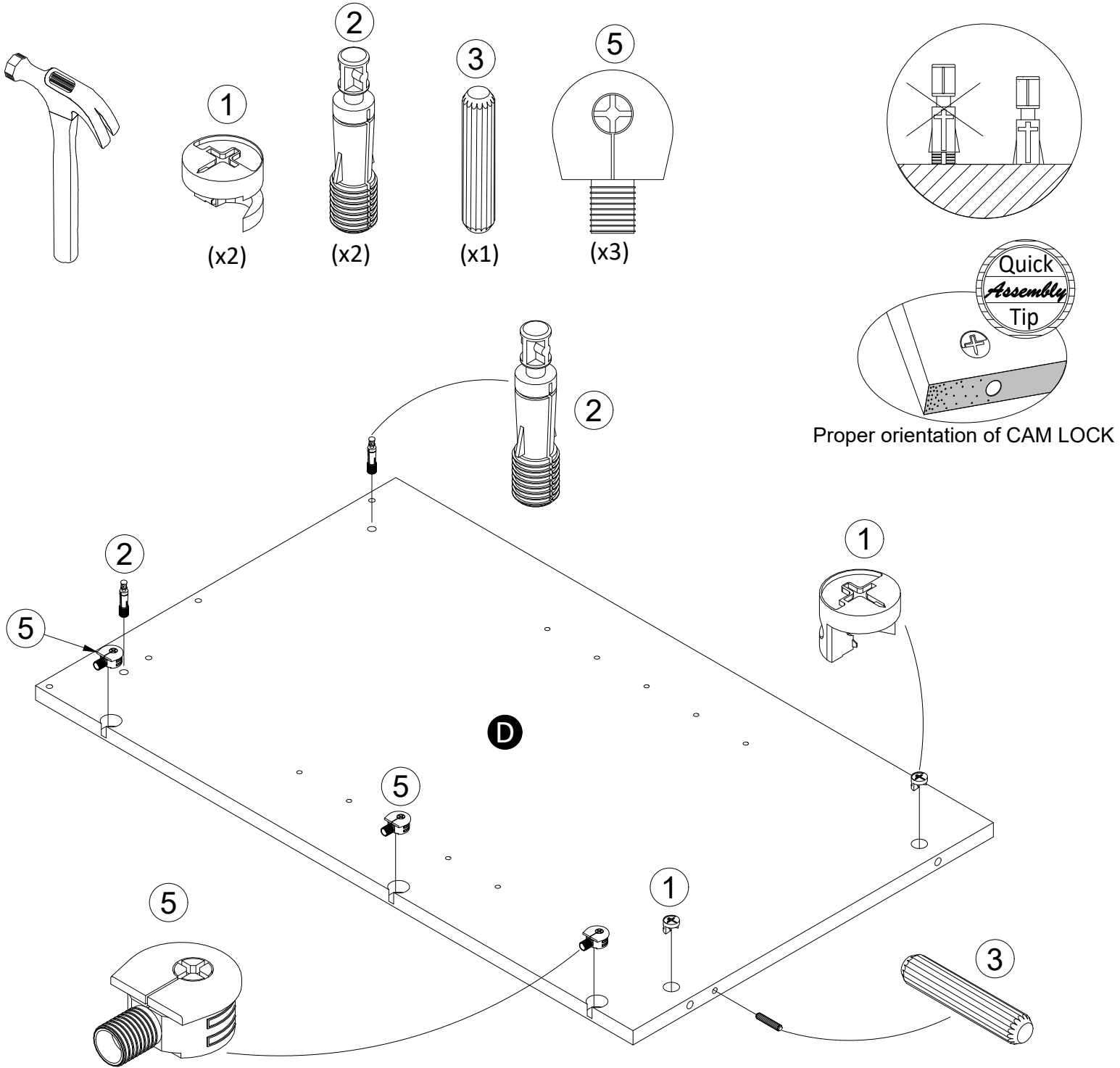

STEP 4

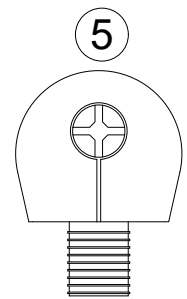
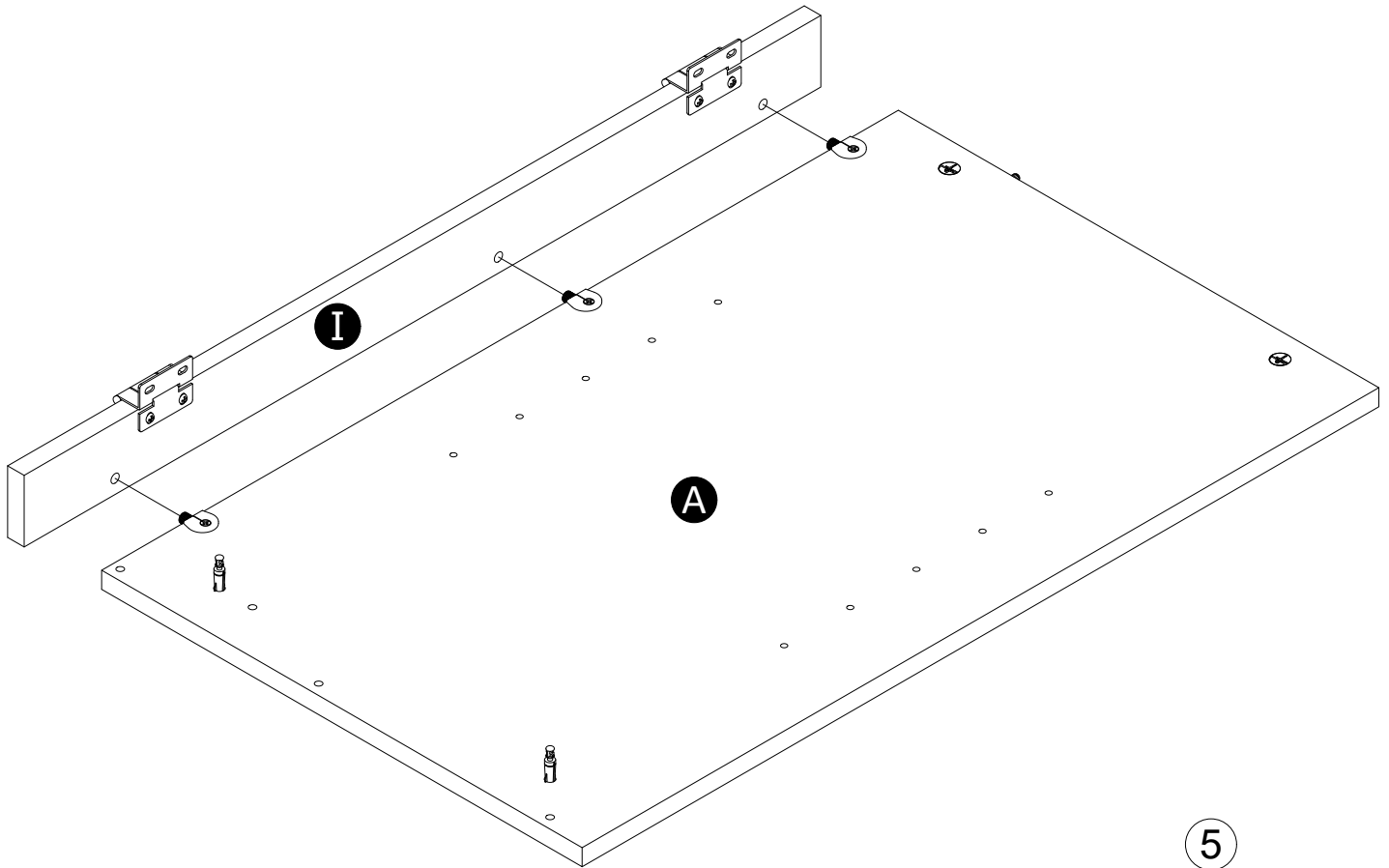
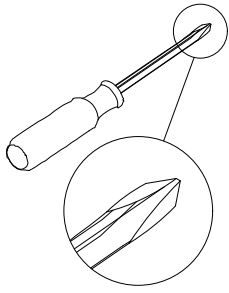

Turn clockwise
to lock in place.

STEP 5

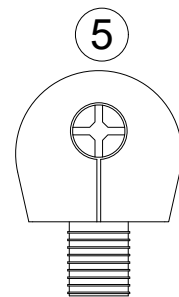
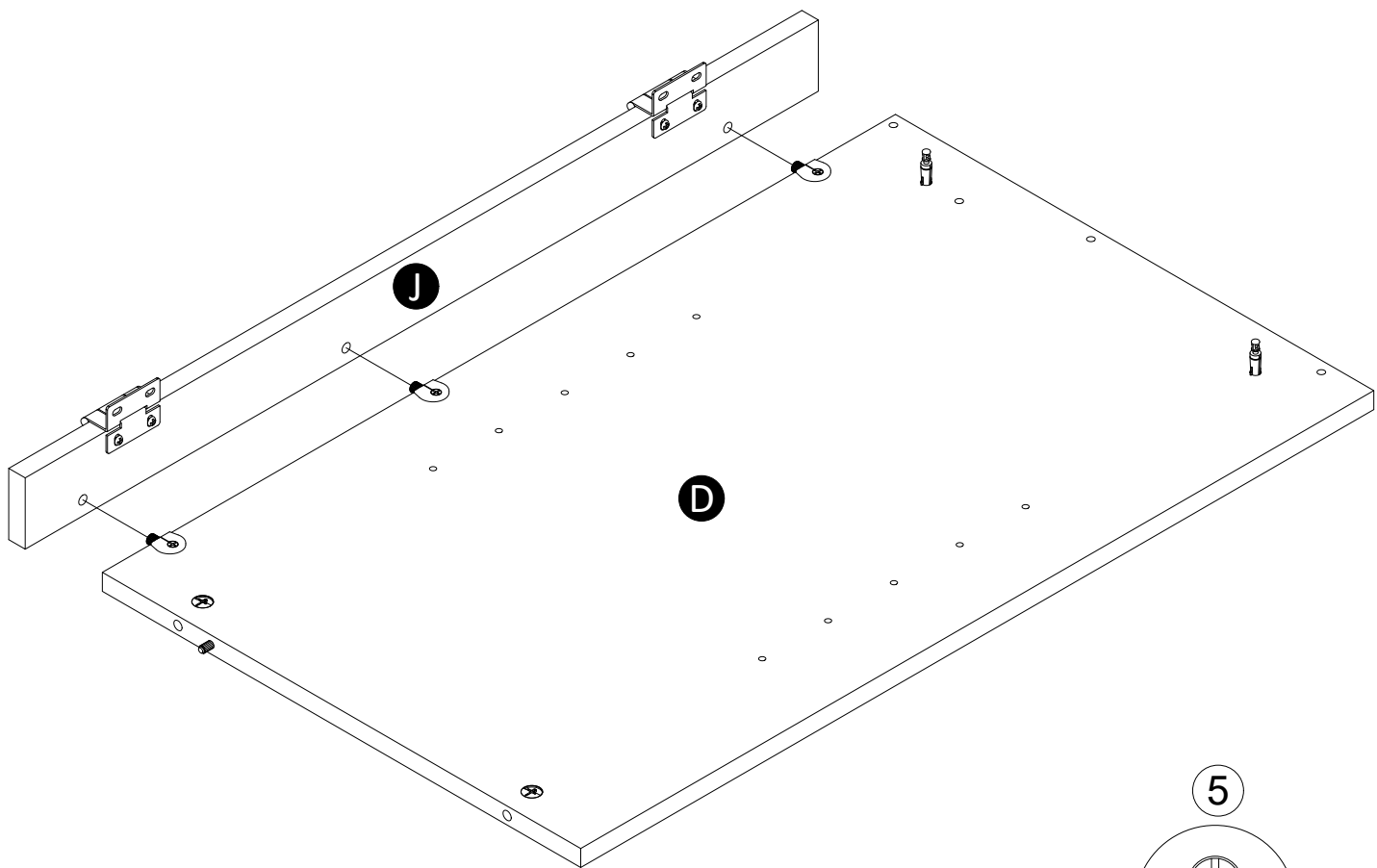
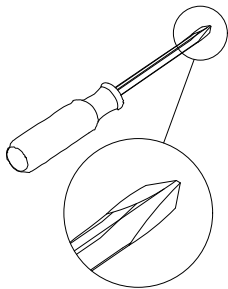

Turn clockwise
to lock in place.

STEP 6

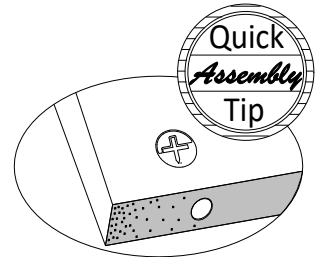
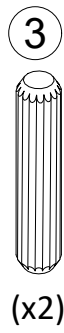
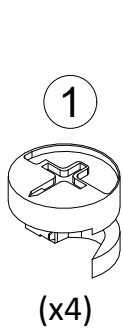
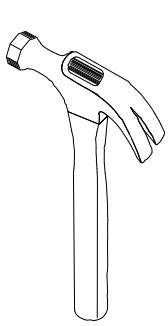

Proper orientation of CAM LOCK

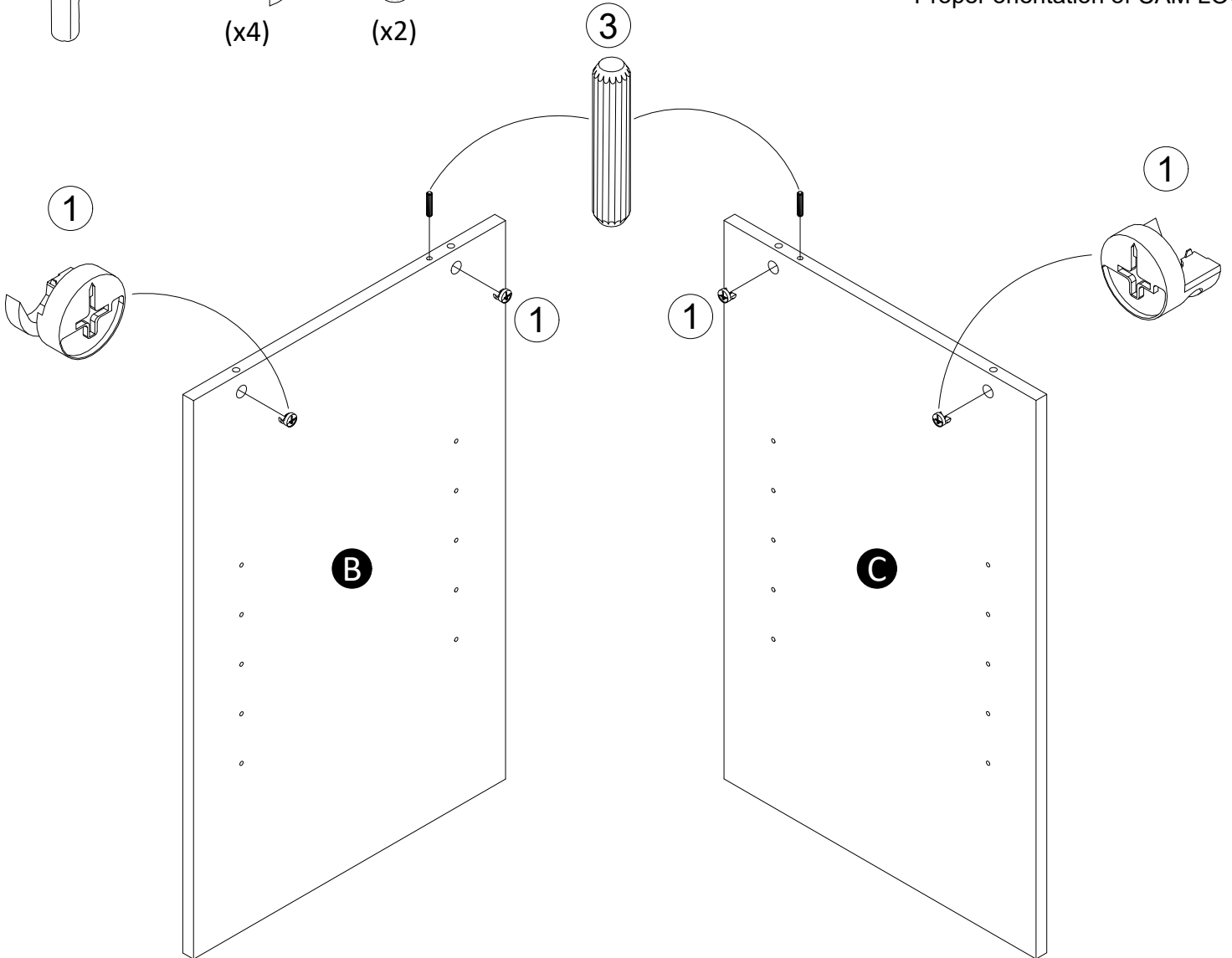

STEP 7

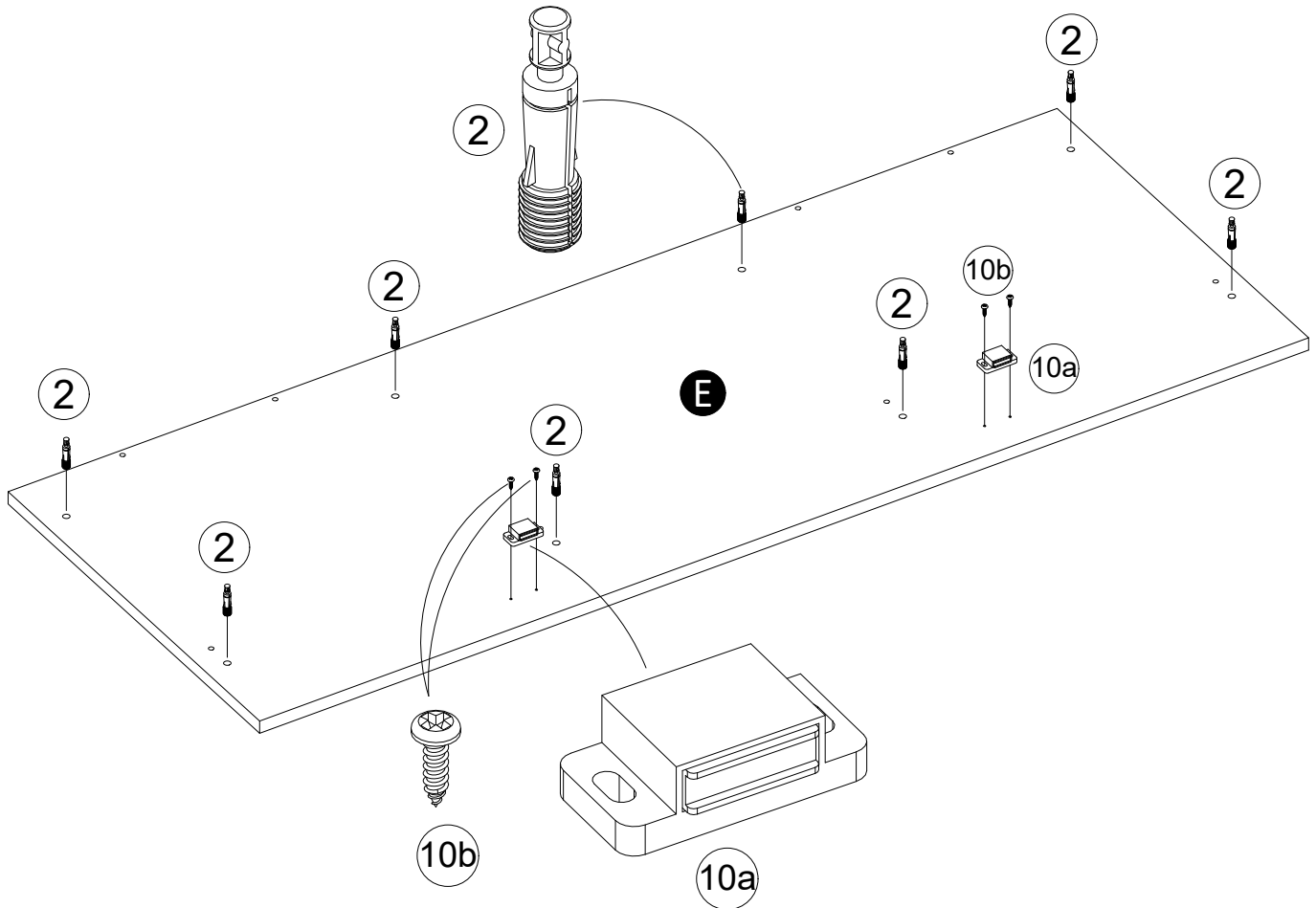
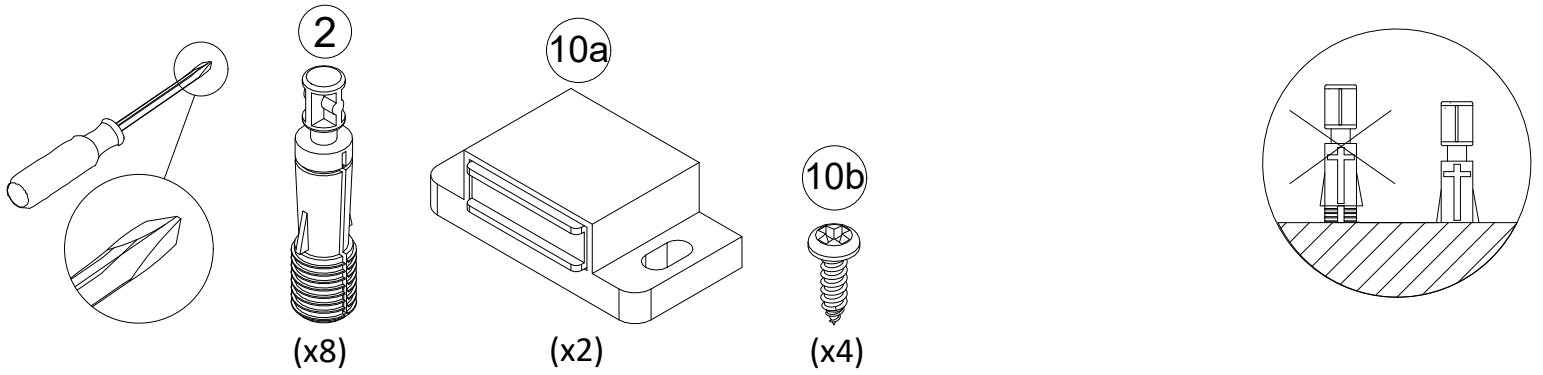

STEP 8

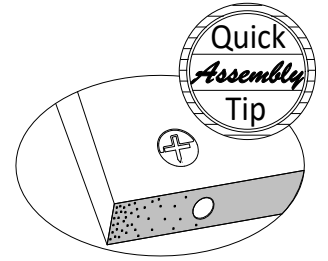
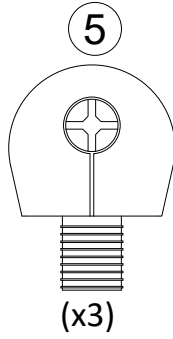
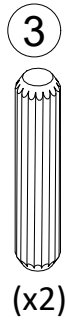
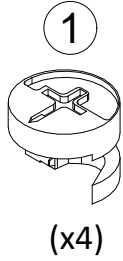
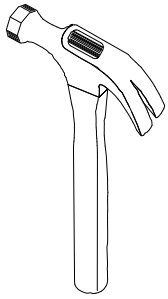

Proper orientation of CAM LOCK

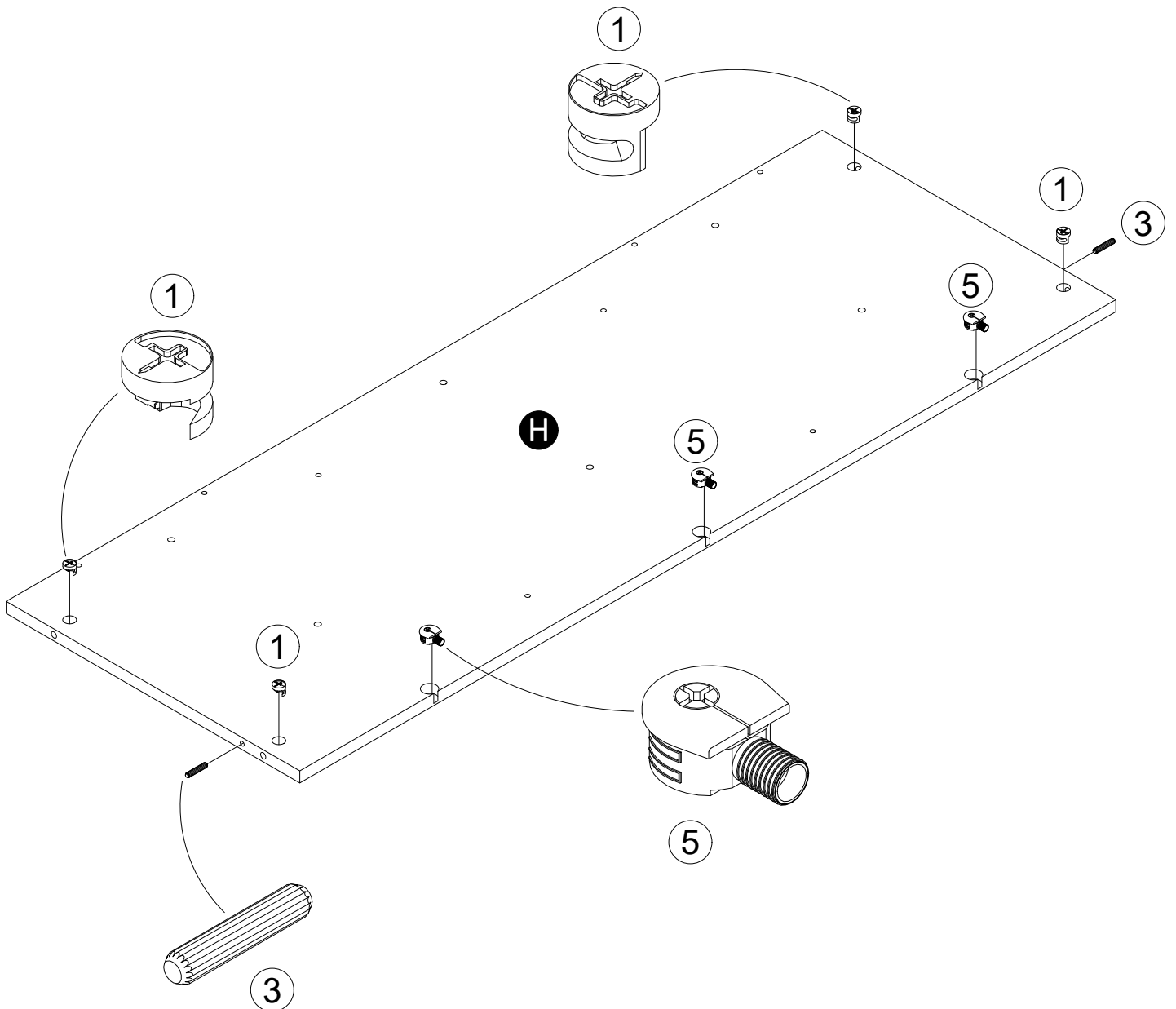

STEP 9

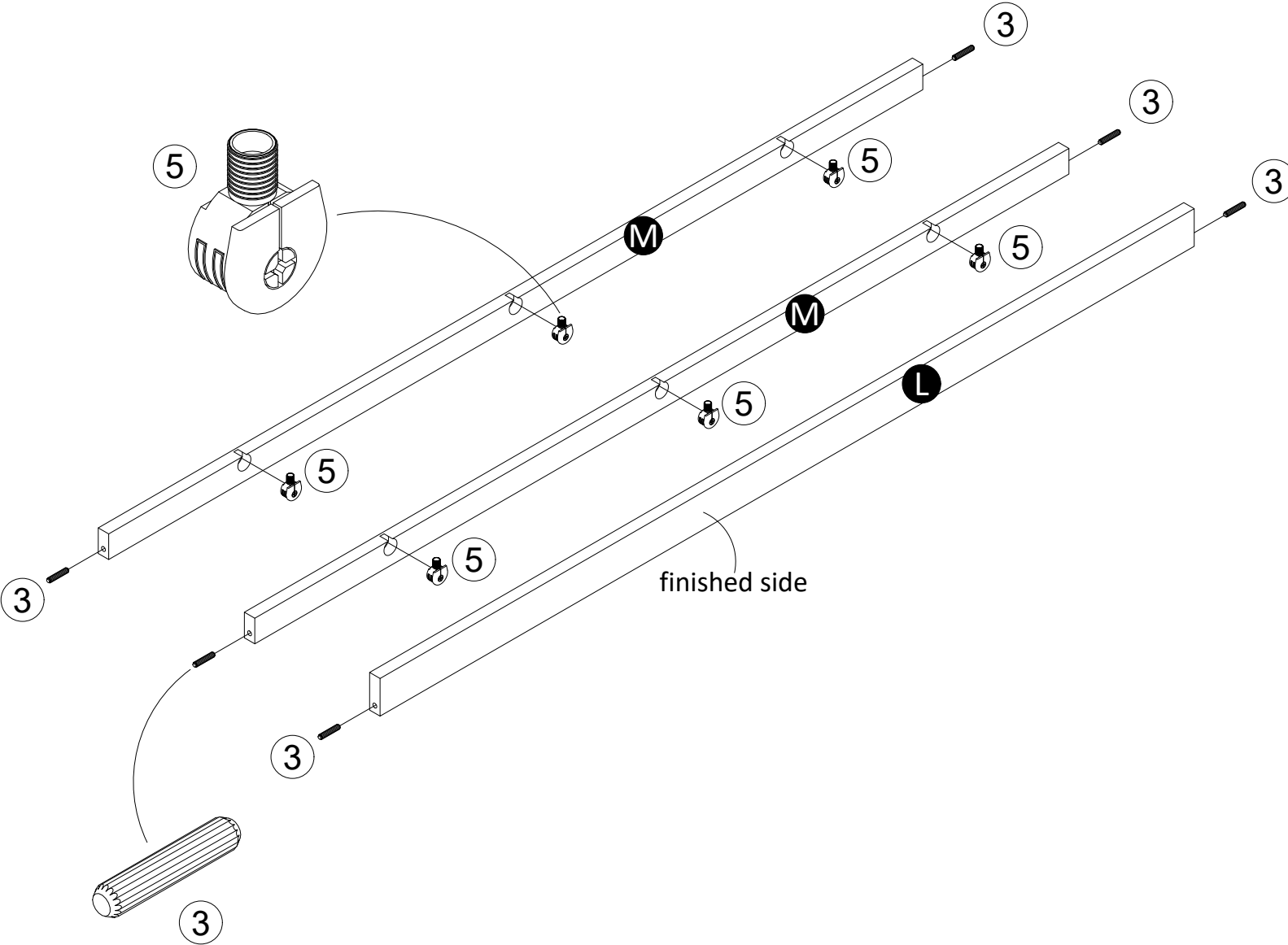
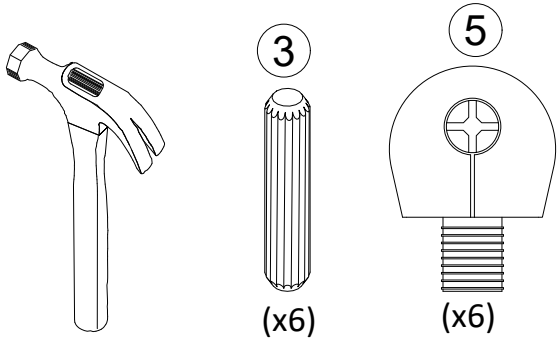

STEP 10

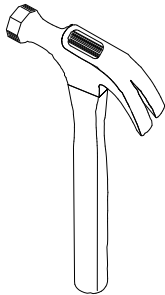

3



(x4)

12

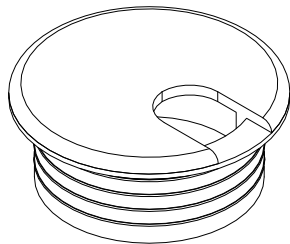

(x2)

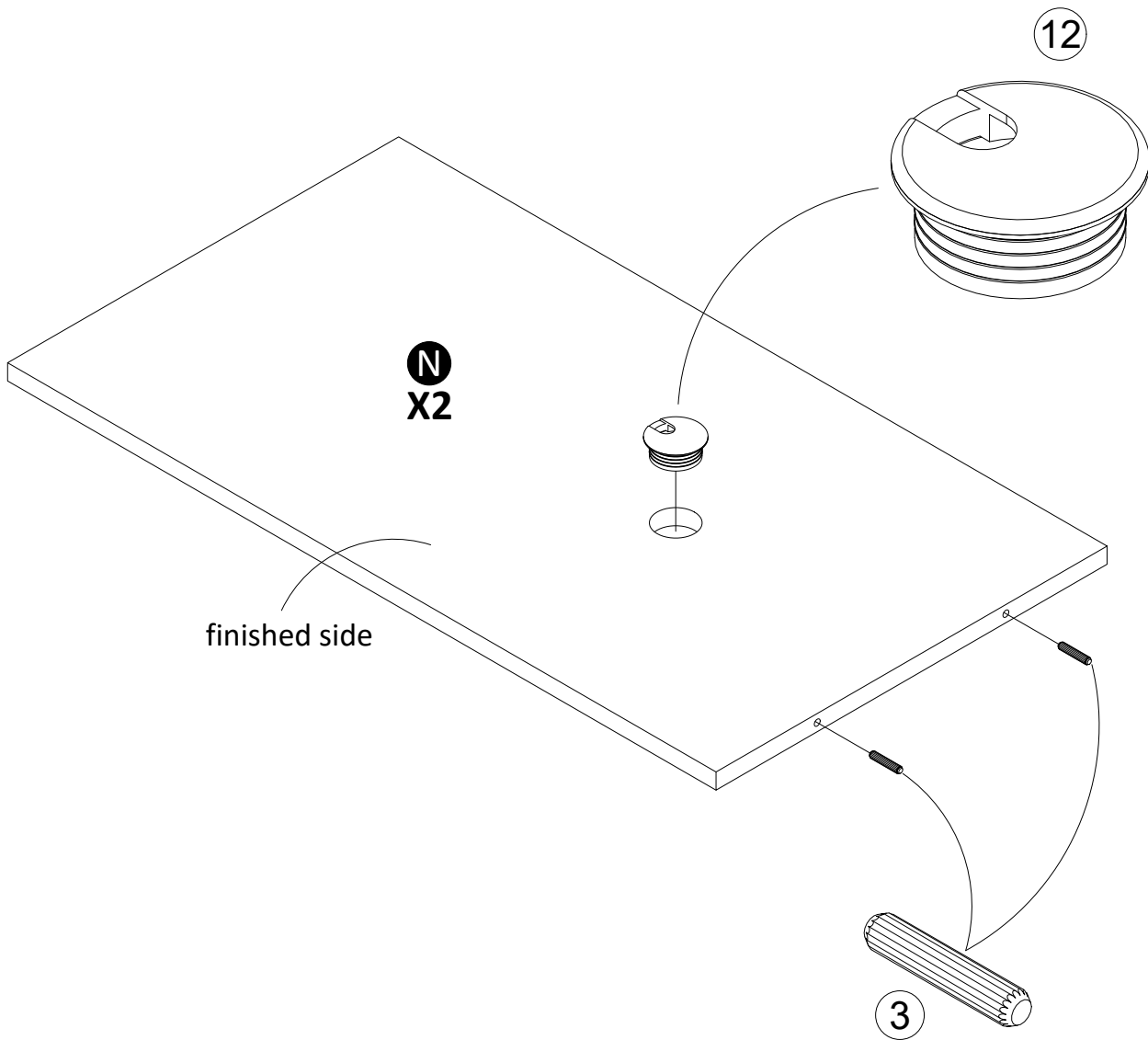

STEP 11

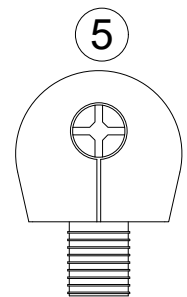
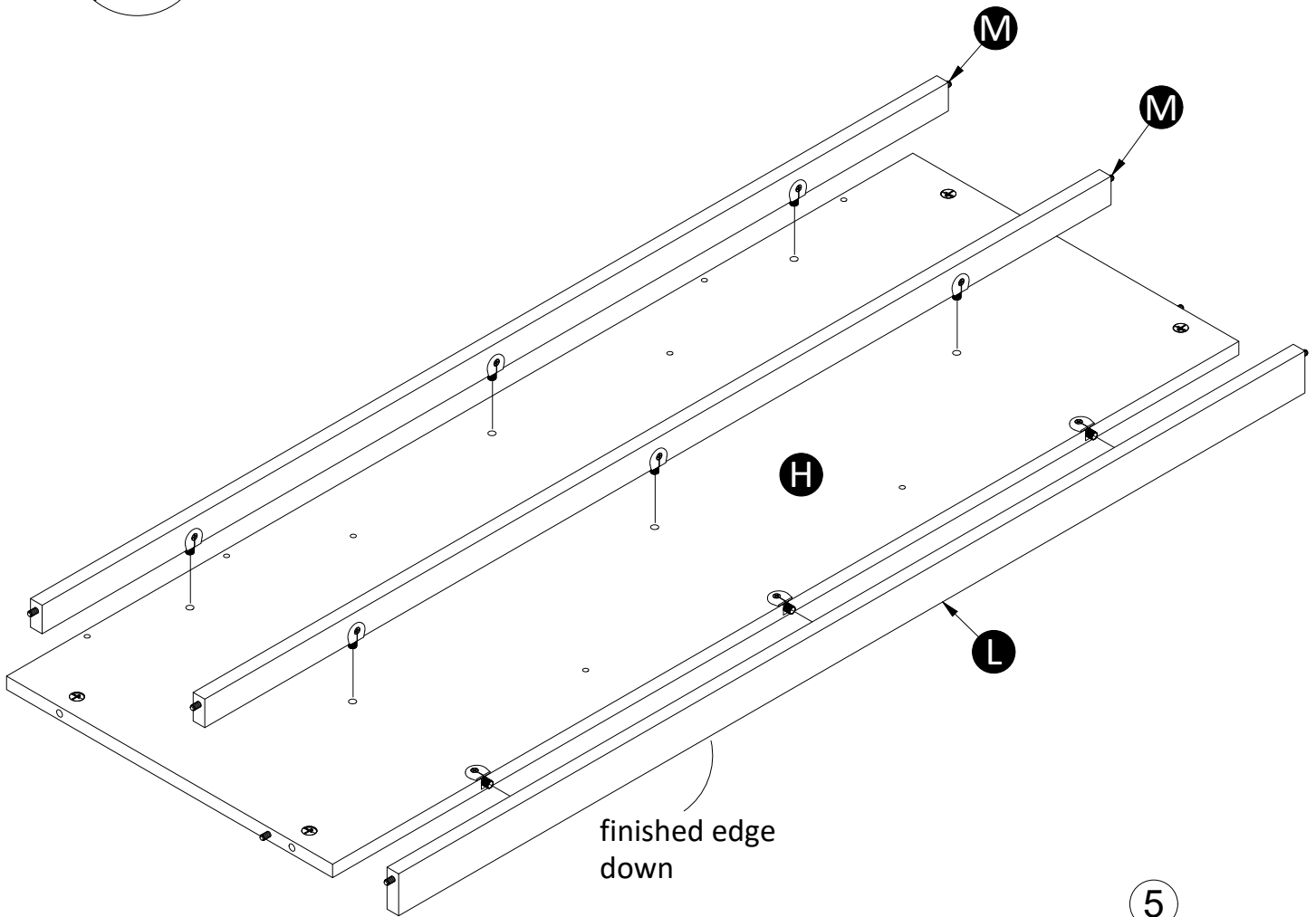
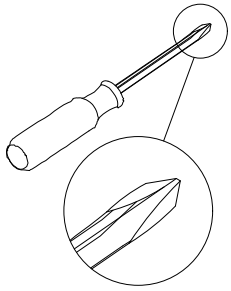

Turn clockwise
to lock in place.

STEP 12

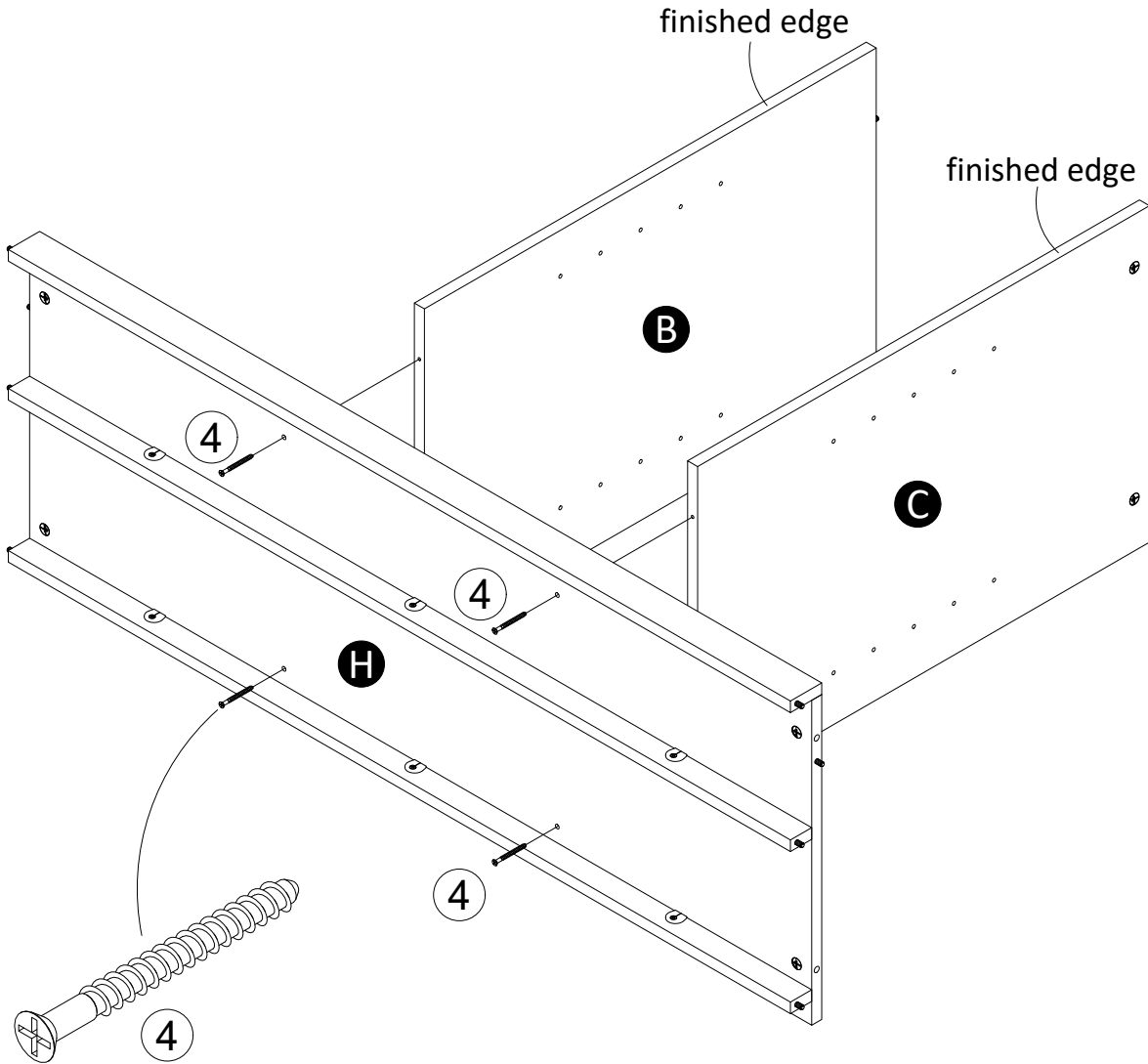
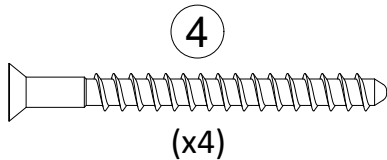
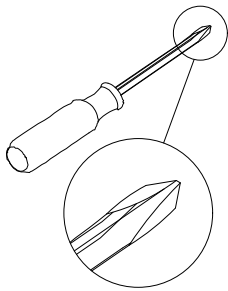

STEP 13

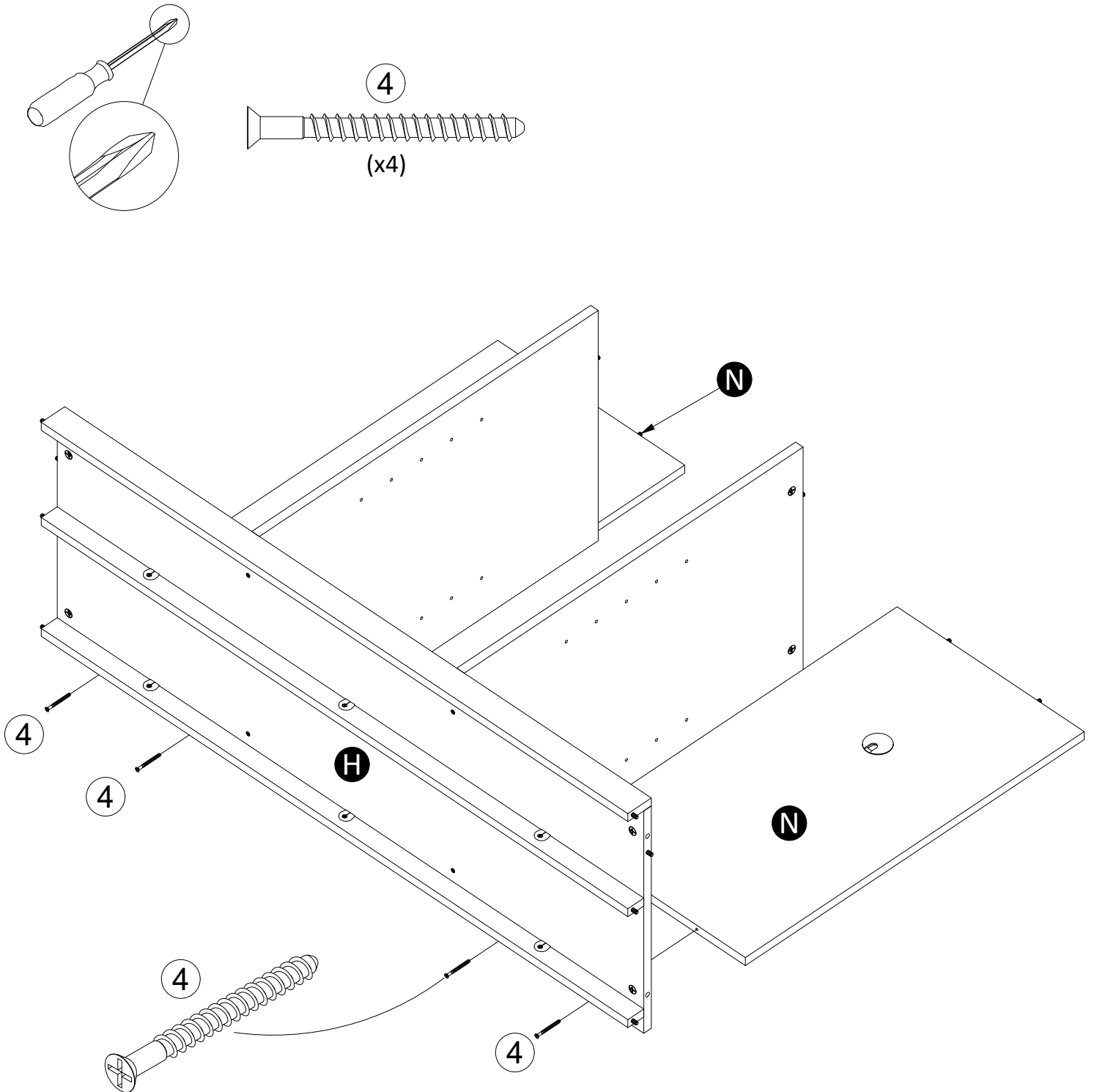

STEP 14

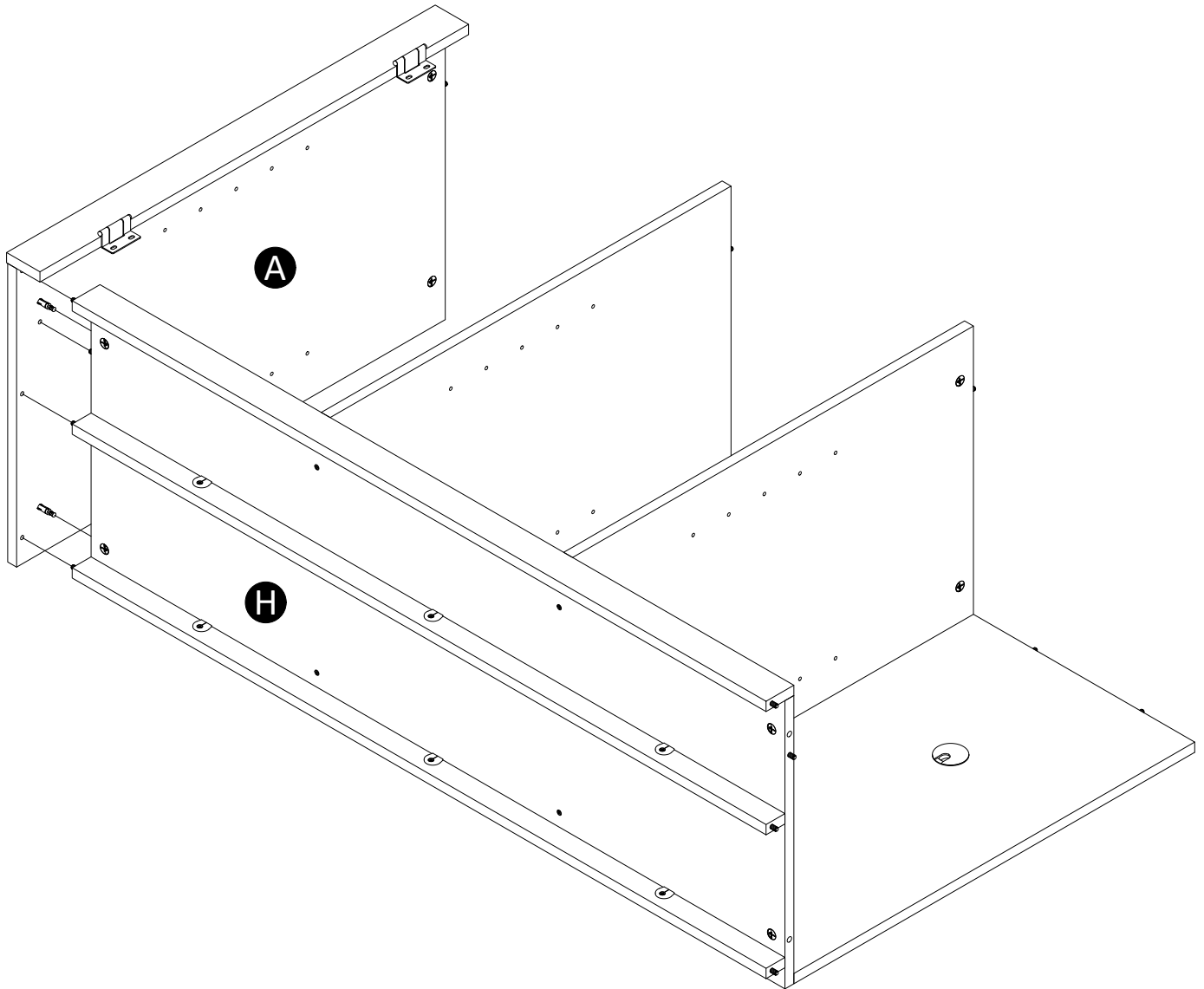
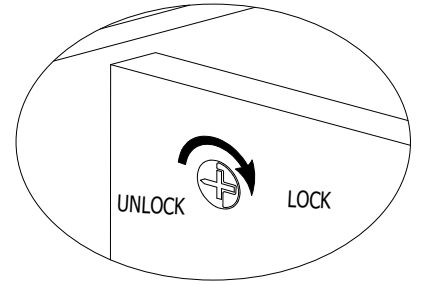
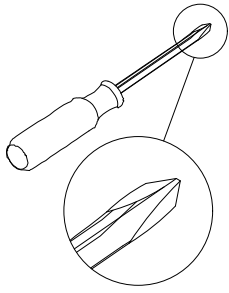

STEP 15

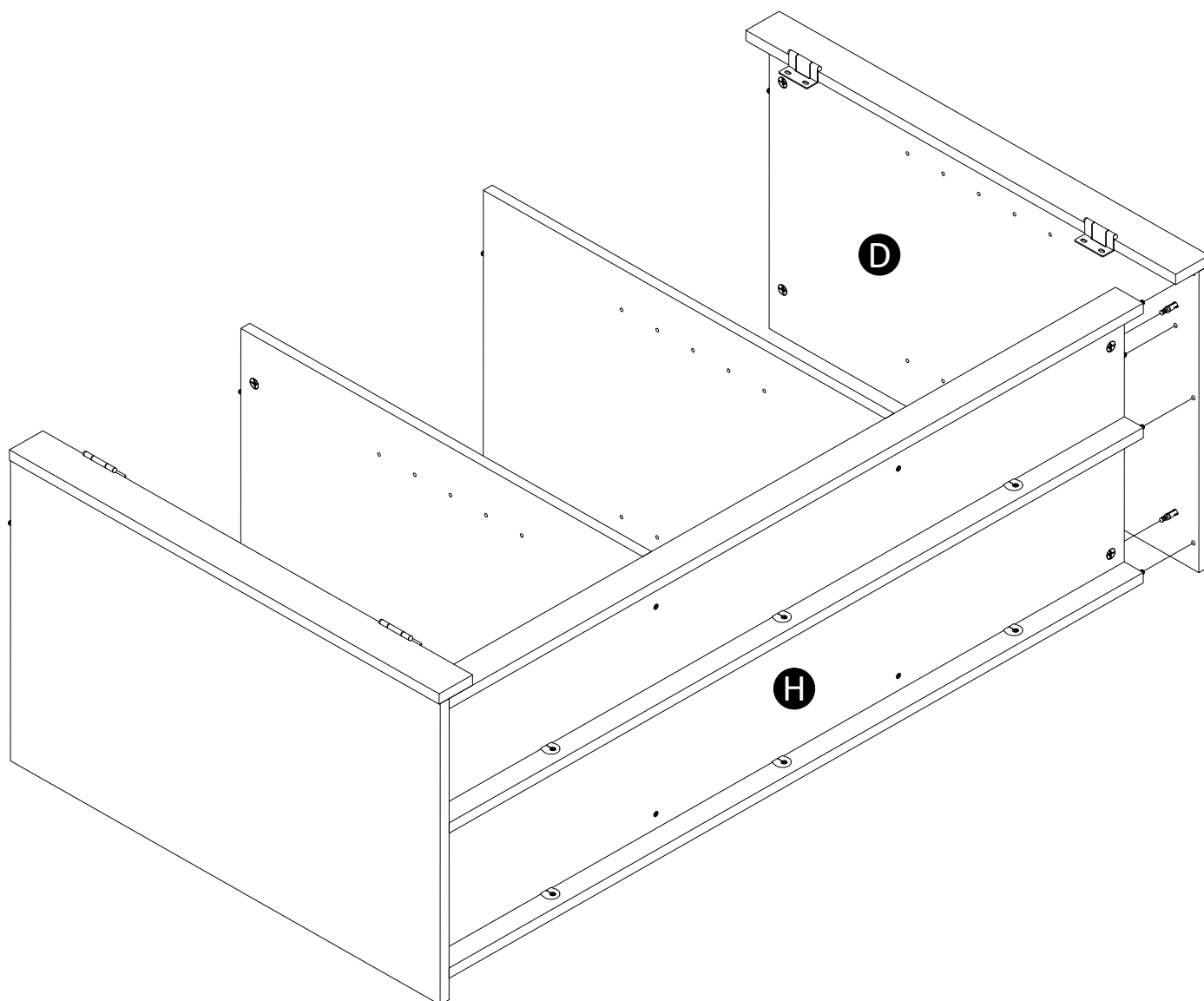
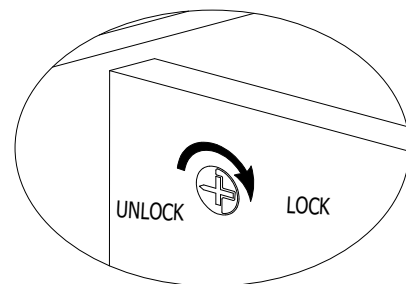
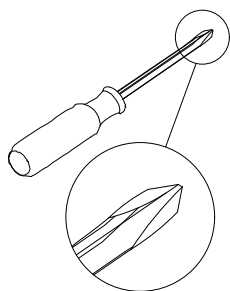

STEP 16

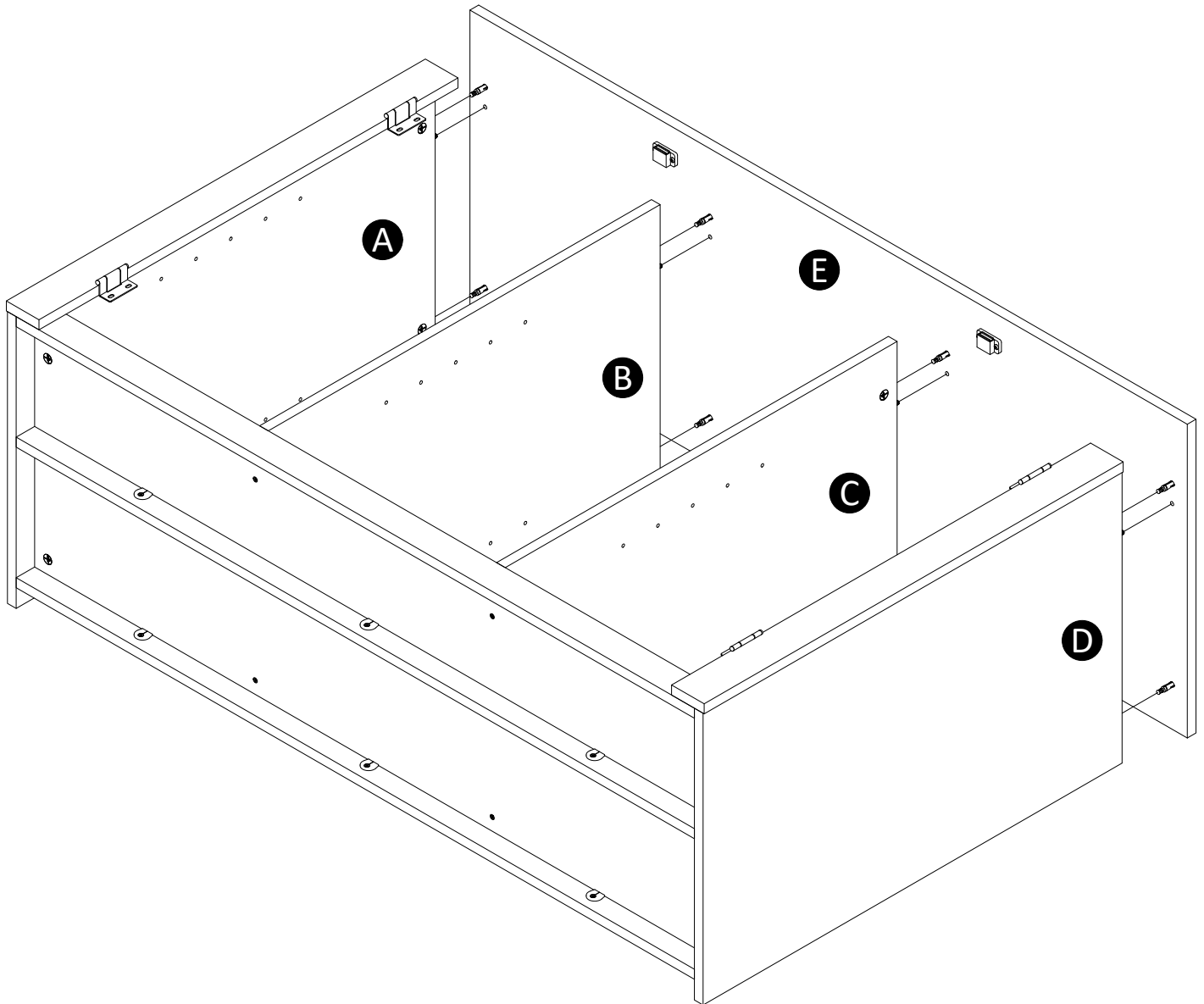
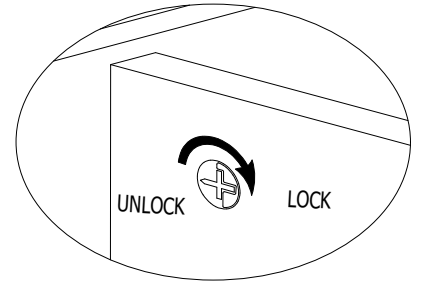
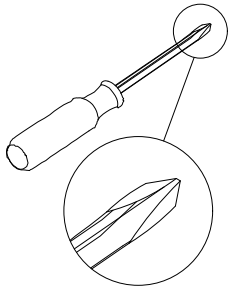

STEP 17

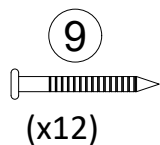
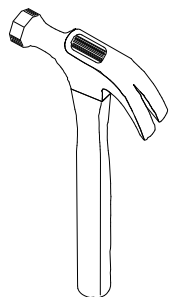

IMPORTANT! THE BACK PANEL IS A STRUCTURAL PART OF THIS UNIT AND MUST BE INSTALLED PROPERLY.

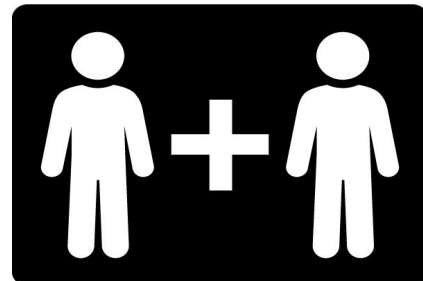

With the help of another person, turn unit onto its front. Attach the center back panel as shown. Nail straight into the unfinished edges.

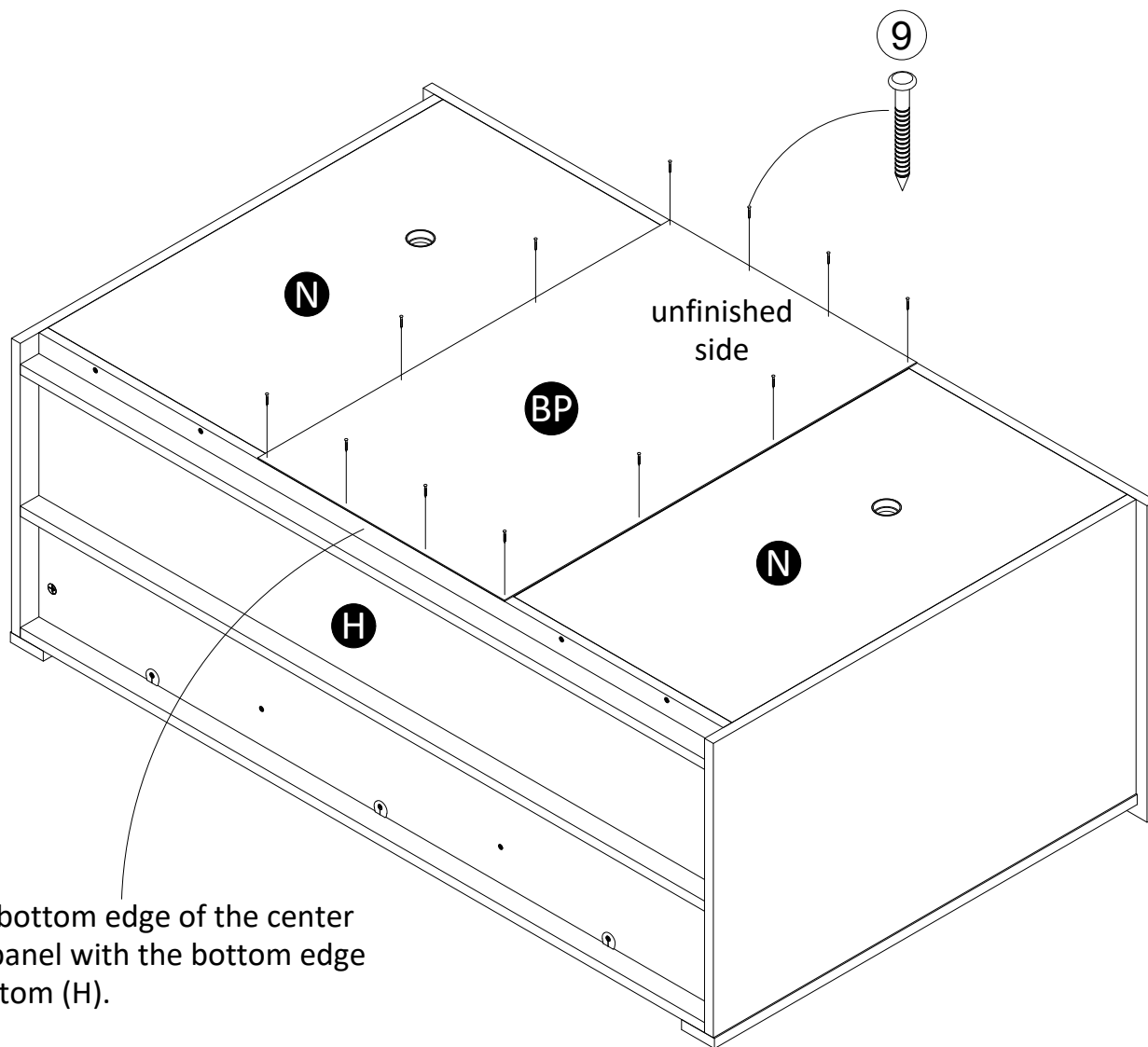

Flush bottom edge of the center back panel with the bottom edge of bottom (H).

STEP 18

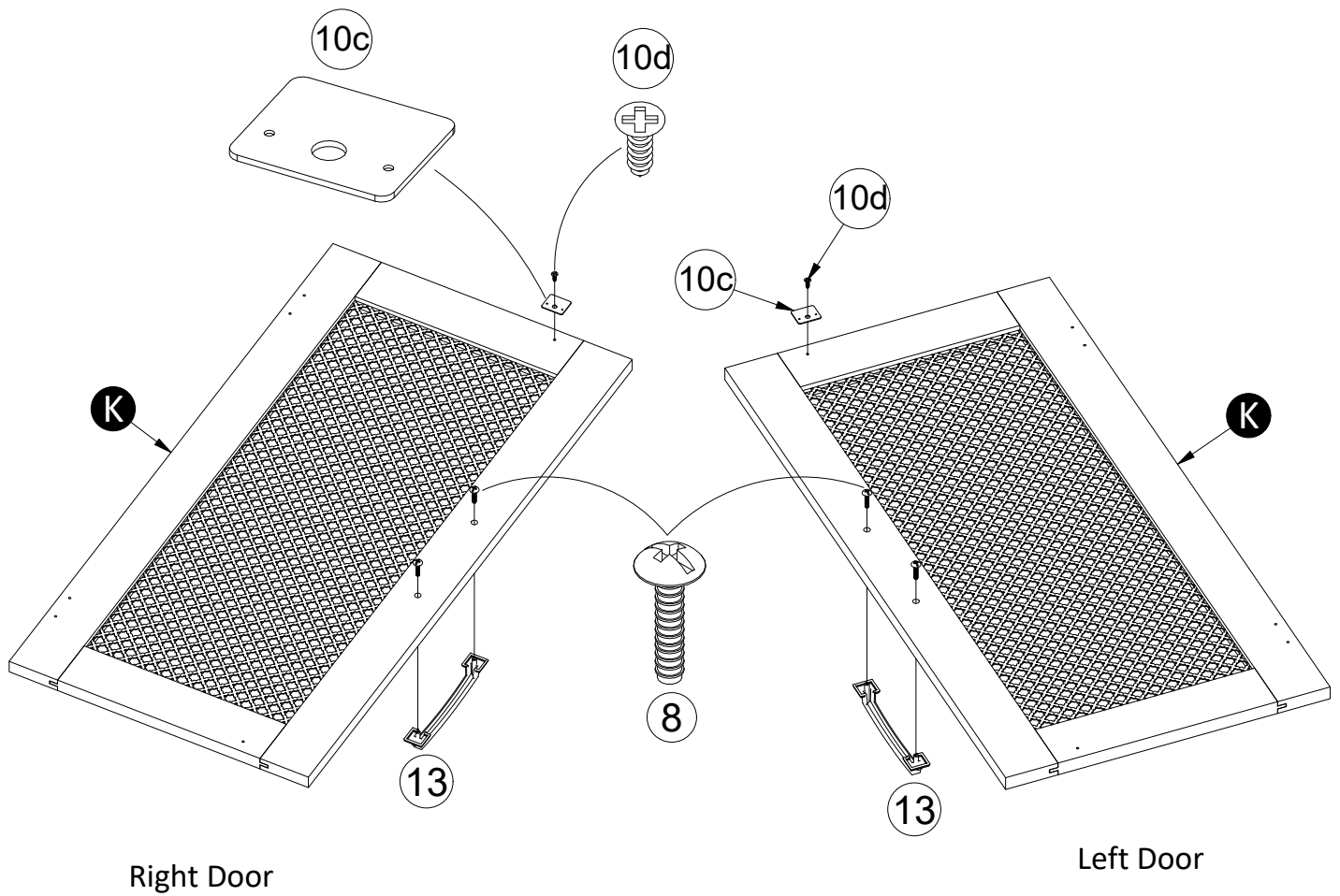
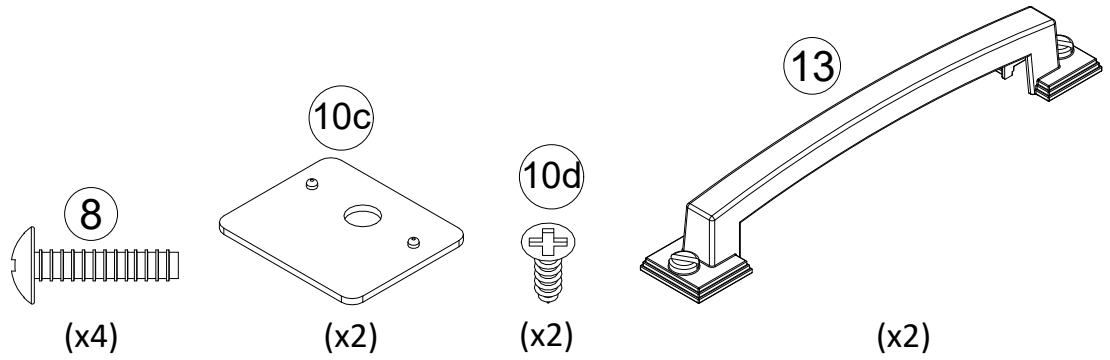
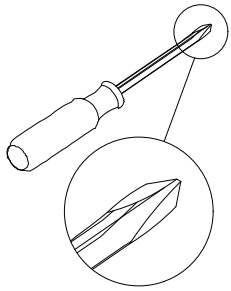

STEP 19

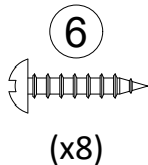
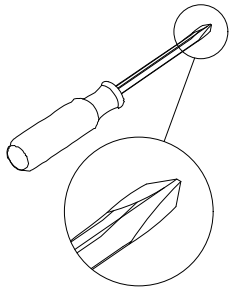

Note:
Hinge and magnetic catch holes
are slotted for door adjustment.
Loosen screws, make needed
adjustments and retighten.

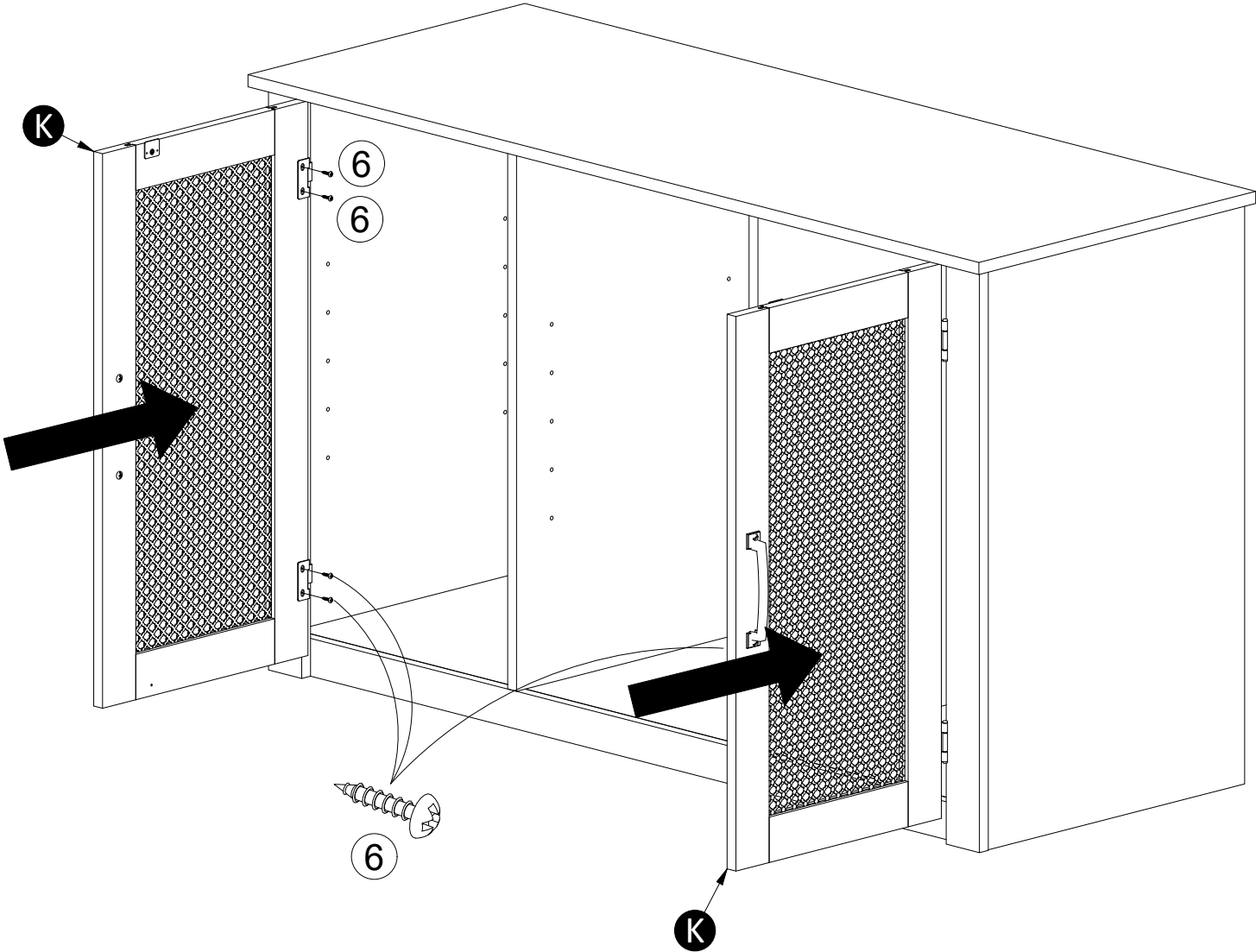

STEP 20

7

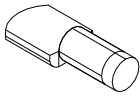

(x12)

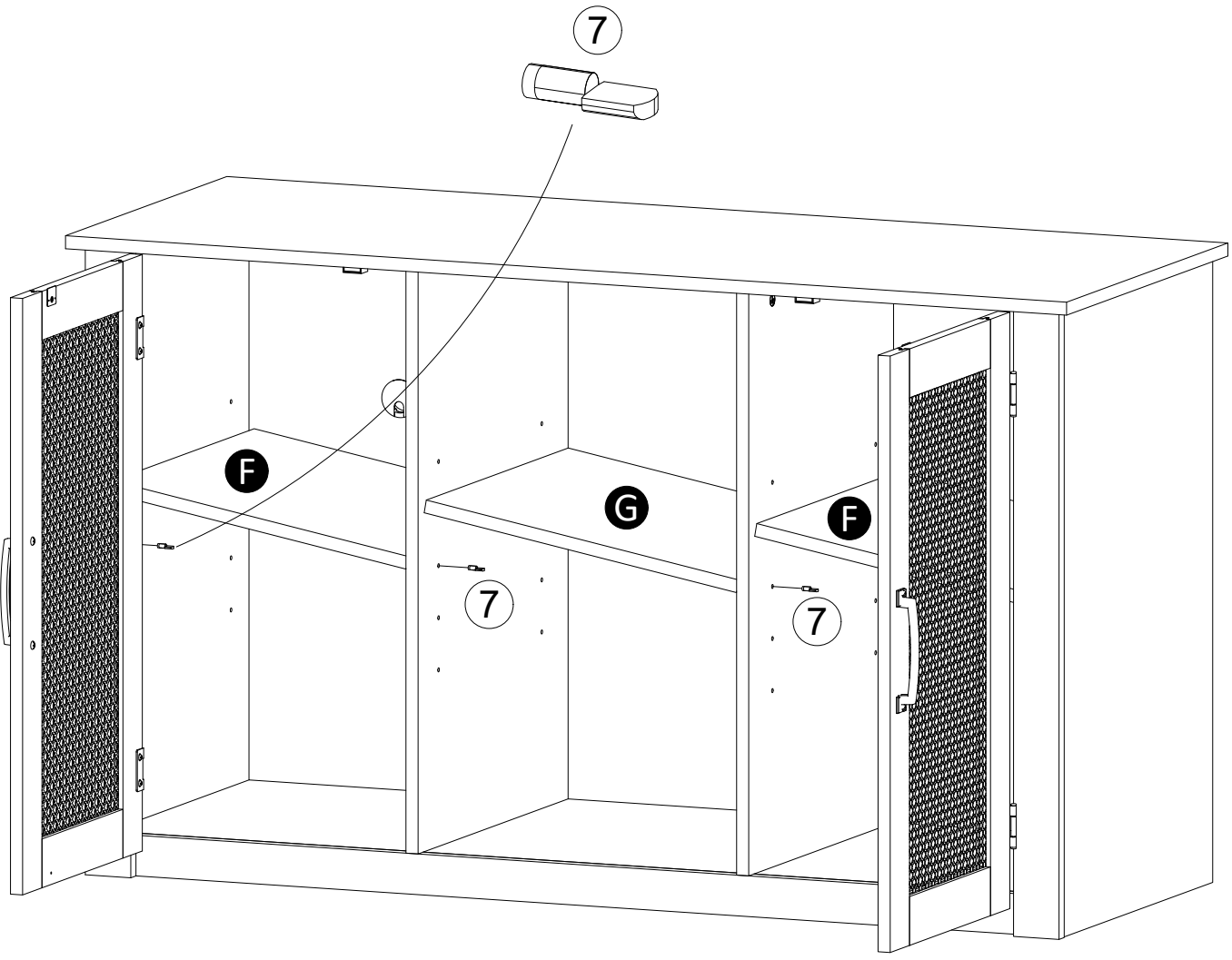

Maximum Loads

This unit has been designed to support the maximum loads shown. Exceeding these load limits could cause sagging, instability, product collapse, and/or serious injury.

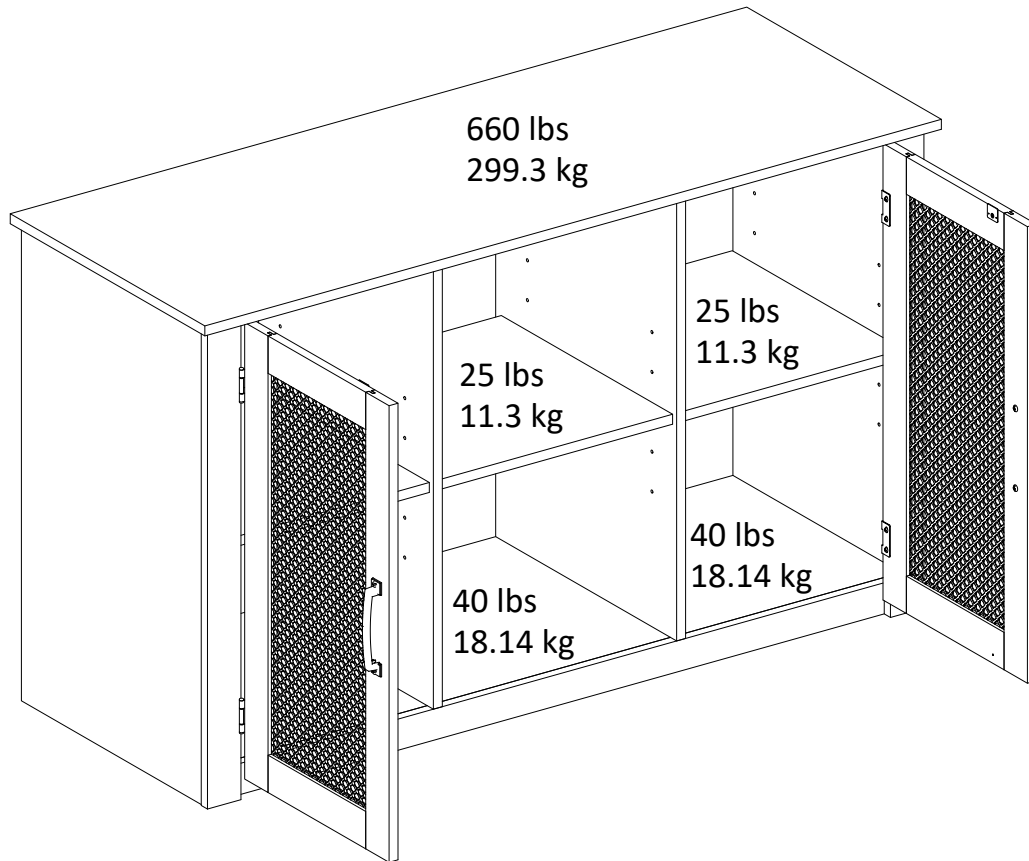

Warning: Risk of injury to persons - do not place a television on this furniture. This furniture is not approved for use with a television.

Certificate of Conformity

1. This certificate applies to the Dorel Home Furnishings, Inc. product identified by this instruction manual.
2. This certificate applies to compliance of this product with the CPSC Ban on Lead-Containing Paint (16 CFR 1303).
3. This product is distributed by: Dorel Home Furnishings, Inc.
410 East First Street South
Wright City, MO 63390
636-745-3351
4. Site of Manufacture: Tiffin OH
5. See front page of instruction manual for date of manufacture.

Register your product to receive the following:



- * New trend details - sneak peek on what's new
- * Surveys - have a voice within our community
- * Exclusive deals and discount codes
- * Quick and easy replacement part service

To register your product, visit ameriwoodhome.com

5 Star Rating



Visit your local retailer's website, rate your purchased product and leave us some feedback!

We would like to extend a big "Thank You" to all of our customers for taking the time to assemble this Ameriwood Home product, and to give us your valuable feedback.

*Thank
You!*

Cubierta Delantera

Este libro de instrucciones contiene información **IMPORTANTE** de seguridad. Por favor lea y manténgalo para referencia en el futuro.

No Regrese este producto! Comuníquese con nuestro amigoso equipo de servicio al cliente para obtener ayuda.

Llámenos al: 1-800-489-3351 (Gratis)

Visitar: www.ameriwoodhome.com

PRECAUCION

Este mueble puede volcarse y causar graves heridas y/o muerte.

Anclar el mueble a un poste de madera en la pared (si esto se requiere).

No Permita que los niños monten el mueble.

Mantenga los artículos más pesados en los cajones de abajo.

Consejos Útiles (página 2)

- Abra su artículo en el área donde usted planea utilizarlo para evitar levantar y moverlo menos
- Identificar, ordenar y contar las piezas antes de intentar ensamblar
- Las clavijas de compresión se golpean con un martillo
- Las diapositivas están marcadas con una R (derecha) y L (izquierda) para la colocación correcta
- Asegúrese de que siempre este el punto localizado en la parte superior de bloqueador de leva este volteado hacia borde exterior
- Utilizar todos los clavos para el panel de atrás y distribuirlos por igual
- El panel de atrás debe utilizarse para asegurarse de que la unidad quede fija y firme
- No use químicas fuertes ni limpiadores abrasivos en este artículo
- Nunca empuje, tire ni arrastre los muebles

Antes de Que Empieces (página 3)

- Lea cuidadosamente cada paso y siga el orden correcto
- Separar y contar todas sus piezas y hardware
- Dése suficiente espacio para el proceso de ensamble
- Tenga las siguientes herramientas: destornillador de cabeza plana, #2 cabeza Phillips
Destornillador y martillo
- Precaución: Si usa un taladro electrónico o un destornillador eléctrico para atornillar, por favor asegúrese que deje de atornillar cuando el tornillo este apretado. Fallar hacer esto puede causar barrer el tornillo.

Sistema de fijar el bloqueo de leva (página 3)

Esta sistema de fijar el bloqueo de leva sera usado en todo el proceso ensamble.

Página 7

Página 30 - wall mounting step

Para mampostería, concreto u otro tipo de paredes:

Acude a tu ferretería local para obtener los anclajes adecuados para fijar de forma segura el soporte de seguridad.

IMPORTANTE: ESTA UNIDAD DEBE ASEGURARSE A UNA PARED PARA EVITAR QUE SE VUELQUE. SIGUE ESTAS INSTRUCCIONES PARA INSTALAR EL SOPORTE DE SEGURIDAD ANTICAÍDA QUE SE PROPORCIONA JUNTO CON ESTE PRODUCTO.

ADVERTENCIA

Un mueble al volcarse puede provocar heridas por aplastamiento que pueden resultar graves o mortales.

Para prevenir que un mueble se vuelque:

- * Instala el dispositivo contra caídas que se proporciona
- * Coloca los artículos más pesados en los cajones de más abajo
- * A menos que esté específicamente diseñado para tal fin, no coloques televisiones ni ningún otro objeto pesado sobre este mueble
- * Nunca permitas que los niños se suban o cuelguen de los cajones, puertas o repisas.
- * Nunca abras más de un cajón a la vez

El uso de los dispositivos contra caídas puede reducir, pero no eliminar por completo el riesgo de que el mueble se vuelque.

OPCIÓN 1: acoplado a un travesaño de la pared (método recomendado)

Ubica un travesaño en la pared utilizando un localizador de travesaños. Coloca tu unidad contra la pared, con el soporte de seguridad alineado en ese lugar. Para facilitar la entrada del tornillo, puedes perforar un agujero guía de 1/8" (3 mm) de diámetro a través del soporte de seguridad hasta llegar al travesaño. Introduce el tornillo en el travesaño de la pared a través del soporte de seguridad. Aprieta el tornillo que no apretaste completamente en el paso 5.

OPCIÓN 2: acoplado a un panel de pared

Coloca tu unidad en el lugar deseado contra una pared y marca la pared a través del soporte de seguridad, luego retira tu unidad hacia un lado. Perfora un agujero de 3/16" de diámetro (5 mm) en el tablero de la pared. Golpea el anclaje de pared para introducirlo en el agujero hasta que quede a ras. Vuelve a colocar tu unidad en su lugar y sujeta el soporte de pared al anclaje de pared con el tornillo. Aprieta el tornillo que no apretaste completamente en el paso 10.

Página 32- weight limit page

CARGA MAXIMA

Esta unidad ha sido diseñada para soportar la carga máxima anotada. El exceder estos límites puede causar inestabilidad, colapsarse y/o causar serias lesiones.

ADVERTENCIA: Riesgo de lesiones a las personas - no coloque un televisor sobre muebles. Este mueble no está aprobado para su uso con un televisor.

Página 16

Registre su producto para recibir lo siguiente:

- * Detalles de nuevas tendencias - Vistazo a lo nuevo
- * Encuestas - alec su voz entre su comunidad
- * Códigos de ofertas y descuentos exclusivos
- * Fácil y rápido servicio de partes de remplace

Para registrar su producto, visite ameriwoodhome.com

Clasificación de 5 estrellas

Visite el sitio web de su tienda local, califique su comprado y denos sus comentarios!

Nos gustaría enviar un gran "Agradecimiento" a todos nuestros clientes por tomarse el tiempo de ensamblar este producto de Ameriwood Home, y por darnos sus valiosos comentarios.

Gracias

Couverture Avant

CE LIVRET D'INSTRUCTION CONTIENT DES INFORMATIONS **IMPORTANTES** SUR LA SÉCURITÉ. VEUILLEZ LIRE ET GARDER POUR UNE RÉFÉRENCE FUTURE

Ne retournez pas ce produit! Contactez notre équipe de service à la clientèle amicale d'abord pour obtenir de l'aide.

Appelez-nous: 1-800-489-3351 (sans frais)

Visitez: www.ameriwoodhome.com

ATTENTION

Le meuble peut basculer et causer des blessures graves ou la mort.

Ancrer le meuble à une planche murale dans le mur (si indiqué).

Ne laissez pas les enfants grimper sur le meuble.

Placez les articles lourds sur les étagères ou dans les tiroirs inférieurs.

Astuces Utiles (page 2)

-Ouvrez votre article dans la zone que vous prévoyez de le garder pour moins de levage lourd

-Identifier, trier et compter les pièces avant d'essayer d'assembler

-Les goujons de compression sont taraudés avec un Marteau

-Les glissières sont marquées d'un R (droit) et d'un L (gauche) pour un bon placement

-Assurez-vous toujours de faire face la pointe situé sur le haut de la Serrure de Came vers le bord extérieur

-Utiliser tous les clous fournis pour le panneau arrière et les répartir également

-Le panneau arrière doit être utilisé pour vous assurer que votre appareil est robuste

-N'utilisez pas de produits chimiques agressifs ou de nettoyeurs abrasifs sur cet appareil

-Ne jamais pousser, tirer, ou faire glisser votre meuble

Avant de Commencer (page 3)

-Lisez attentivement chaque étape et suivez le bon ordre

-Séparez et comptez toutes vos pièces et matériaux

-Donnez-vous suffisamment de place pour l'assemblage

-Avoir les outils suivants: tournevis à tête plate, #2 tournevis Phillips, et Marteau

-Attention: Si vous utilisez une perceuse électrique ou un tournevis électrique pour visser, veillez à ralentir et arrêter lorsque la vis est bien serrée. Le non-respect de cette consigne peut endommager la vis.

Système de Fixation de Came (page 3)

Ce Système de Fixation de Came sera utilisé tout au long de l'assemblage

Page 30 - wall mounting step

Pour la maçonnerie, le béton ou d'autres matériaux de mur :

Visiter votre quincaillerie locale pour obtenir des ancrs appropriées qui permettront de fixer solidement le support de sécurité.

IMPORTANT : CE MEUBLE DOIT ETRE SÉCURISÉ AU MUR POUR EVITER QU'IL NE BASCULE. SUIVRE CES INSTRUCTIONS POUR INSTALLER LE SUPPORT DE SÉCURITÉ ANTI-BASCULEMENT FOURNI AVEC CE PRODUIT.

AVERTISSEMENT

Des blessures graves ou mortelles peuvent se produire en cas de basculement des meubles.

Pour éviter le basculement :

- * Installer la pièce anti-basculement fournie
- * Placer les objets les plus lourds dans les tiroirs les plus bas
- * Sauf si spécifiquement conçu pour y être installé, ne pas poser de téléviseur ou d'autres objets lourds sur de ce produit
- * Ne jamais laisser enfants grimper ou s'accrocher sur les tiroirs, les portes ou les étagères
- * Ne jamais ouvrir plus d'un tiroir à la fois

L'utilisation des pièces anti-basculement peut uniquement réduire, mais pas éliminer le risque de basculement.

OPTION 1 : ancrage sur un colombage (méthode privilégiée)

Localisez un colombage dans le mur à l'aide d'un détecteur de colombage. Placez votre meuble contre le mur en maintenant le support de sécurité aligné au même endroit. Pour faciliter l'insertion de la vis, il est recommandé de percer un trou d'essai de 1/8" de diamètre (3 mm) à travers le support de sécurité dans le colombage. Passer la vis à travers le support de sécurité pour l'insérer dans le colombage. Serrer la vis qui n'a pas été complètement serrée à l'étape 10.

OPTION 2 : ancrage dans la cloison sèche

Positionnez votre meuble sur la zone ciblée contre un mur et faites une marque sur le mur à travers le support de sécurité, puis déplacez votre meuble de côté. Percez un trou de 3/16" de diamètre (5 mm) dans le panneau mural. Tapez sur l'ancre murale pour l'introduire dans le trou jusqu'à ce qu'il soit parfaitement aligné et installé. Placez votre meuble sur son emplacement et fixer le support mural à l'ancre murale avec la vis. Serrez la vis qui n'a pas été complètement serrée à l'étape 10.

Page 32 - weight limit step

CHARGES MAXIMALES

Ce meuble a été conçu pour supporter les charges maximales indiquées. En excédant ces limites de charge, le meuble pourrait devenir instable, s'effondrer, et/ou causer des blessures graves.

AVERTISSEMENT : Risque de blessure corporelle - ne pas placer une télévision sur ce meuble. Ce meuble n'est pas approuvé pour une utilisation avec une télévision.

Page 16

Enregistrez votre produit pour recevoir les éléments suivantes:

- * Détails sur les nouvelles tendances - un aperçu sur les nouveautés
- * Sondages - avoir une voix au sein de notre communauté
- * Offres exclusives et codes promo
- * Service de pièces de rechange rapide et facile

Pour enregistrer votre produit, visitez ameriwoodhome.com

5 Étoiles

Visitez le site Web de votre détaillant local, évaluez votre produit acheté et laissez-nous quelques commentaires !

Nous tenons à offrir un grand "Merci" à tous nos clients pour avoir pris le temps d'assembler ce produit "Ameriwood Home", et de nous donner vos commentaires précieux.

Merci