

PACKAGE DELIVERY BOX BOÎTE DE LIVRAISON DE COLIS CAJA DE ENTREGA DE PAQUETES

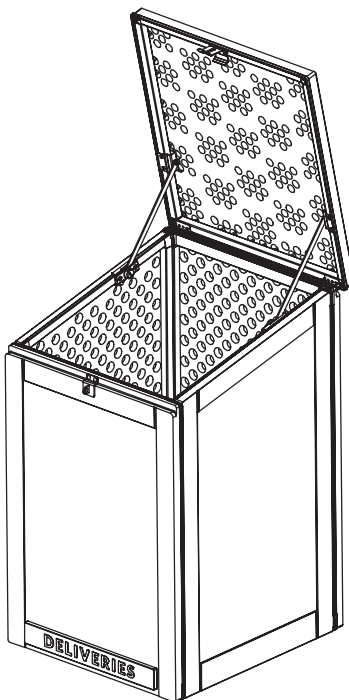

MODEL / MODÈLE / MODELO #88333

ASSEMBLY INSTRUCTIONS INSTRUCTIONS D'ASSEMBLAGE INSTRUCCIONES DE ENSAMBLAJE



READ & SAVE BELOW INSTRUCTIONS BEFORE ASSEMBLY

1. Please separate and identify all parts, making sure that you have all of the parts listed.
2. To avoid any scratches during assembly, please assemble on a soft mat or similar surface.
3. Follow step by step instructions.
4. Do not tighten screws until all the screws are properly installed.
5. Tighten screws securely, do not over-tighten.



LIRE & CONSERVER LES INSTRUCTIONS CI-DESSOUS AVANT D'ASSEMBLER

1. Séparez et identifiez toutes les pièces, en vous assurant d'avoir toutes les pièces indiquées.
2. Pour éviter les rayures pendant l'assemblage, veuillez assembler sur une carpeite douce ou une surface similaire.
3. Suivez les instructions étape par étape.
4. Ne pas serrer les vis jusqu'à ce que toutes les vis soient installées correctement.
5. Serrez les vis solidement, ne pas serrer excessivement.



GUARDAR Y LEER INSTRUCTIONS ANTES DE ARMAR

1. Por favor separe e identifique todas las partes, asegurándose que tiene todas las piezas indicadas.
2. Para evitar cualquier rasguño durante la asamblea, favor de armar sobre una superficie suave.
3. Siga las instrucciones paso por paso.
4. No apretar los tornillos hasta que todos los tornillos hayan sido instalados.
5. Apretar los tornillos seguramente, no apretar en exceso.

CARE AND CLEANING:

- To clean, wipe with damp cloth.
Do not use bleach, acid solvents or abrasive cleaners.
- Please do not put any transparent glassy substance or similar on the unit to avoid potential sunlight focusing damage.
- Do not stand or climb on unit.

SOIN ET ENTRETIEN:

- Pour nettoyer, essuyez avec un chiffon humide.
Ne pas utiliser d'eau de javel, de solvants acides ou de nettoyeurs abrasifs.
- S.V.P. Ne pas mettre de substance vitrée transparente ou autre chose similaire sur le meuble afin d'éviter des dommages potentiels causés par le soleil.
- Ne pas monter ou grimper sur le meuble.

CAUIDADO Y LIMPIEZA:











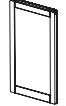

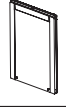

- Para limpiar, limpie con un paño húmedo. No utilice blanqueador, disolventes acidos o limpiadores abrasivos.
- Favor de no ponga ninguna substancia vidriosa transparente o similar en la unidad para evitar daño potencial de enfoque de la luz del sol.
- No se pare o suba en la unidad.

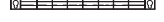
Tighten all the screws to 60% first, then tighten to 100% once fully assembled.

Serrez toutes les vis à 60% d'abord puis serrez à 100% une fois complètement assemblées.

Apriete todos los tornillos al 60% primero y luego apriete al 100% una vez que esté completamente ensamblado.

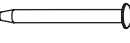
PARTS / LES PIÈCES / PARTES

PART PARTIE PARTE	IMAGE IMAGEN IMAGE	DESCRIPTION DESCRIPTION DESCRIPCIÓN	QTY. QTÉ. CANT.
A		Left Panel Panneau Gauche Panel Izquierdo	1
B		Back Panel Panneau Arrière Panel Posterior	1
C		Right Panel Panneau Droit Panel Derecho	1
D		Front Panel Panneau Avant Panel Frontal	1
E		Bottom Panel Panneau Inférieur Panel Inferior	1
F		Top Panel Panneau Supérieur Panel Superior	1
G		Delivery Plate Plaque De Livraison Placa De Entrega	1
H		Generic Plate Plaque Générique Placa Genérica	1
I			8
J			1
K			1
L			1
M			1
AA			2
BB			8
CC			4

ASSEMBLY INSTRUCTIONS / INSTRUCTIONS D'ASSEMBLAGE / INSTRUCCIONES DE ENSAMBLAJE

1.

Insert **A** & **C** into **B**.

Pull up on **A** & **C** and push down on **B** to lock.

Insérez **A** & **C** dans **B**.

Tirez vers le haut sur **A** & **C** et poussez vers le bas sur **B** pour verrouiller.

Inserte **A** & **C** en **B**.

Tire hacia arriba de **A** & **C** y presione hacia abajo **B** para bloquear.

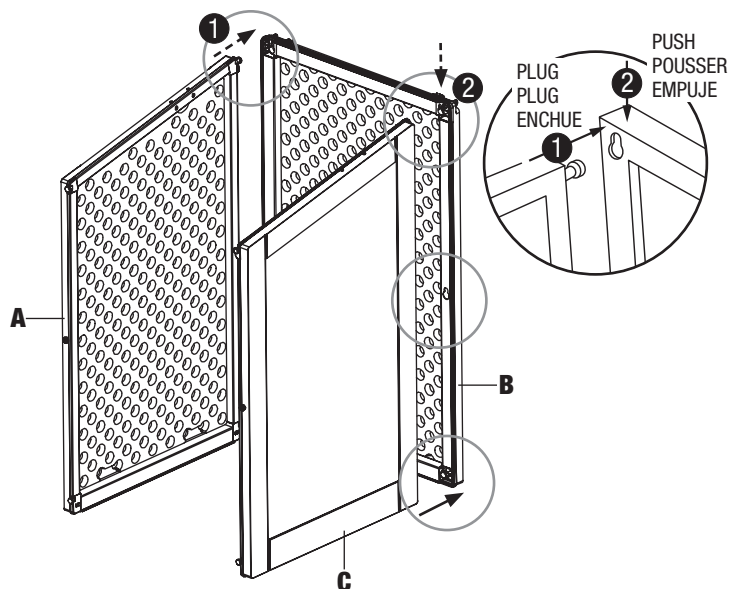

3.

Insert **A** & **C** into **D**.

Pull up on **A** & **C** and push down on **D** to lock.

Insérez **A** & **C** dans **D**.

Tirez vers le haut sur **A** & **C** et poussez vers le bas sur **D** pour verrouiller.

Inserte **A** & **C** en **D**.

Tire hacia arriba de **A** & **C** y presione hacia abajo **D** para bloquear.

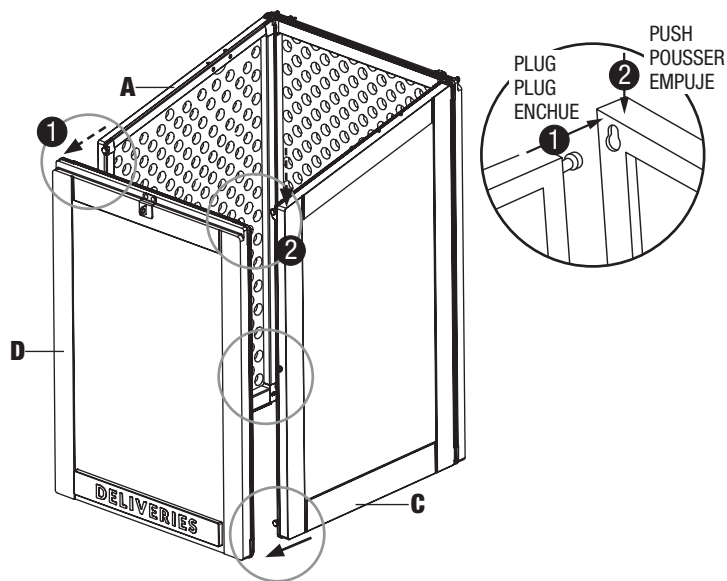

2.

Push down on part **G** or **H** to secure to part **D**.

Appuyez sur la partie **G** ou **H** pour fixer à la partie **D**.

Empuje hacia abajo la parte **G** o **H** para asegurar a la parte **D**.

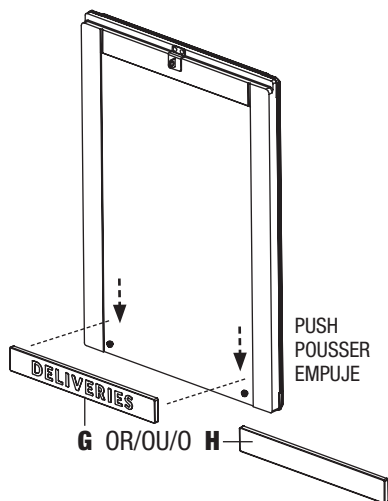

4.

Insert **I** connectors into slots on pieces **A, B, C** and **D**.

Place part **E** face up onto **I** connectors.

Insérez les connecteurs **I** dans les fentes des parties **A, B, C** et **D**.

Placez la partie **E** face vers le haut sur les connecteurs **I**.

Inserte los conectores **I** en las ranuras de las piezas **A, B, C** y **D**.

Coloque la parte **E** boca arriba en los conectores **I**.

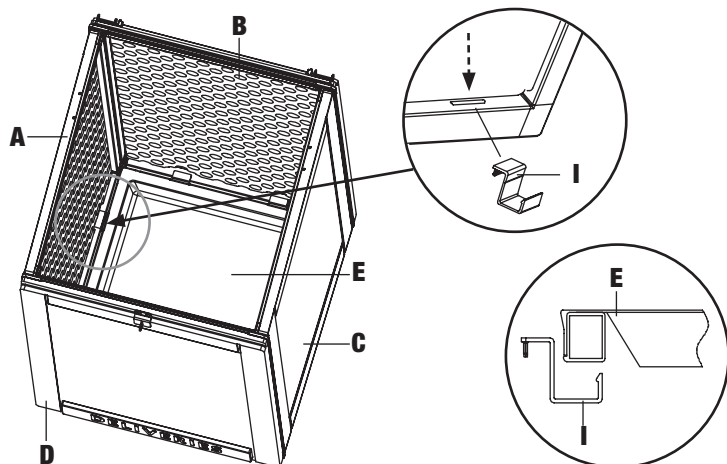

5.

Attach part **J** to panel **F** using **BB**.

Fixez la partie **J** au panneau **F** en utilisant la partie **BB**.

Coloque la parte **J** en los panel **F** usando las parte **BB**.

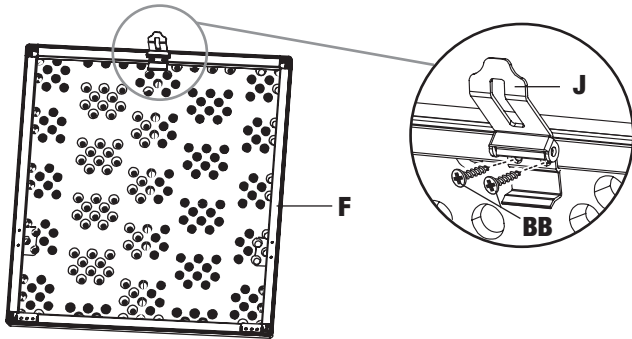

6.

Attach part **K** to panel **D** using **BB**.

Fixez la partie **K** au panneau **D** en utilisant la partie **BB**.

Coloque la parte **K** en los panel **D** usando las parte **BB**.

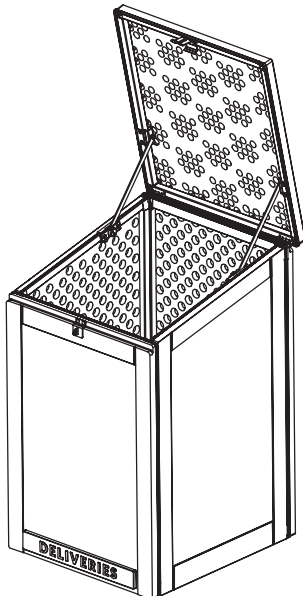
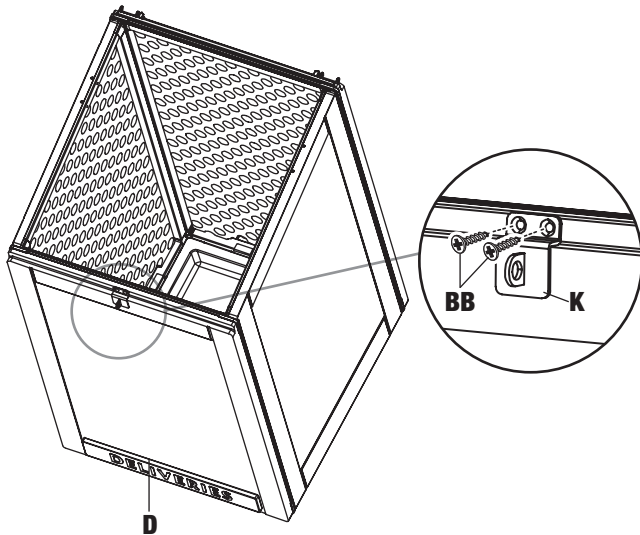

7.

Attach panel **F** onto panel **B** using (2) **AA**.

Attachez le panneau **F** au panneau **B** en utilisant (2) **AA**.

Fije el panel **F** en el panel **B** usando (2) **AA**.

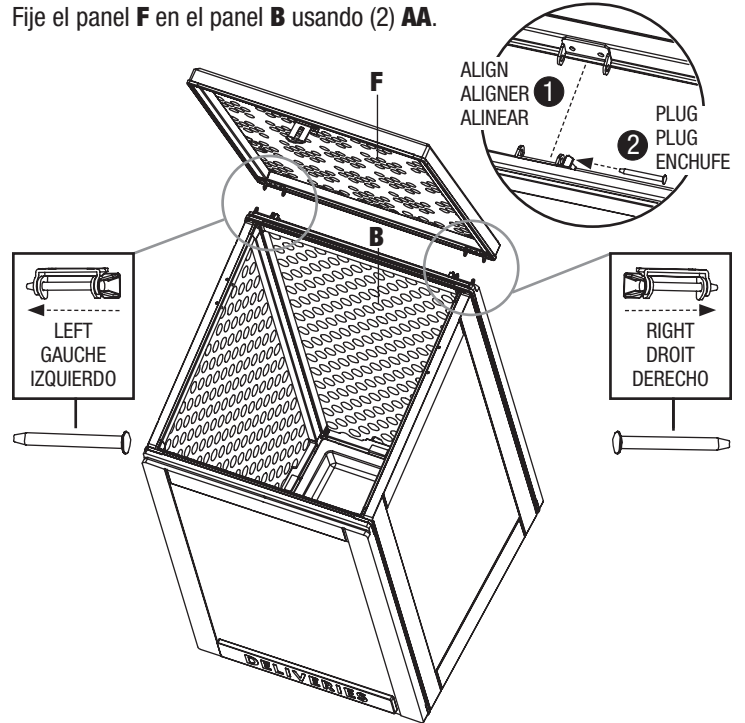

8.

Attach part **L** to **A** and **M** to **C** with part **CC**.

Attach **L** and **M** to panel **F** using **BB**.

Attachez la pièce **L** à **A** et **M** à **C** avec **CC**.

Fixez **L** et **M** au panneau **F** à l'aide de **BB**.

Conecte la parte **L** a **A** y **M** a **C** con la parte **CC**.

Conecte **L** y **M** al panel **F** usando **CC**.

