

## 4917335COM 54" TV Stand 9048335COM 54" Fireplace TV Stand

Date of Purchase \_\_\_ / \_\_\_ / \_\_\_  
Lot Number:

B344917335COM00EL

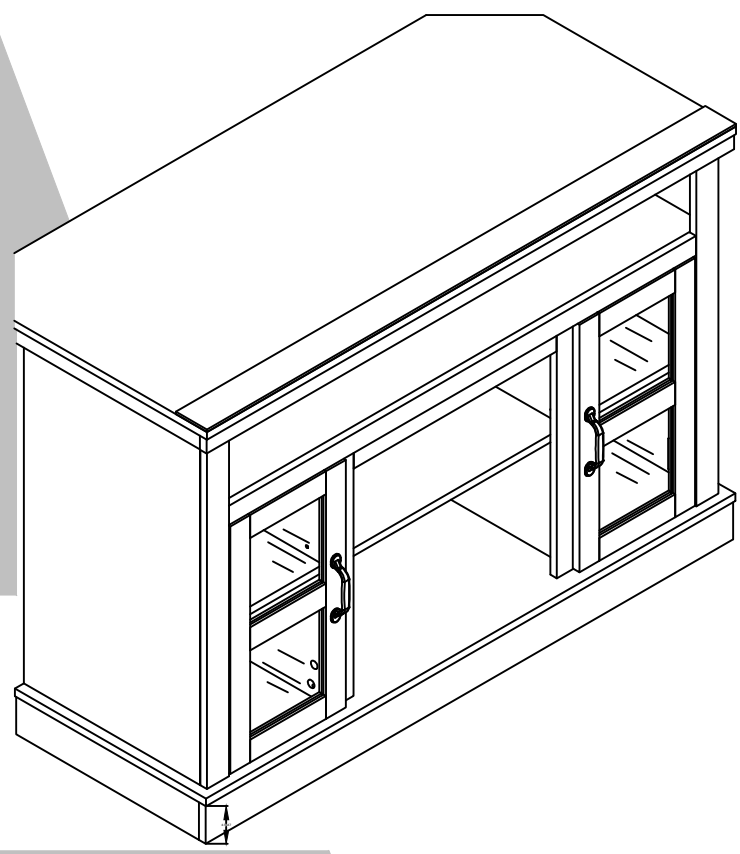

THIS INSTRUCTION BOOKLET CONTAINS **IMPORTANT** SAFETY INFORMATION. PLEASE READ AND KEEP FOR FUTURE REFERENCE.

**Do Not Return This Product!**  
Contact our customer service team for help first.  
**Call:** 1-800-489-3351 (toll free)  
Monday-Friday 9am - 5pm CST  
**Visit:** [www.ameriwoodhome.com](http://www.ameriwoodhome.com)



### **WARNING**

- Unit can tip over causing severe injury or death.
- Anchor unit to stud in wall (if instructed to).
- Do Not allow children to climb on unit.
- Put heavy items on lower shelves or drawers.

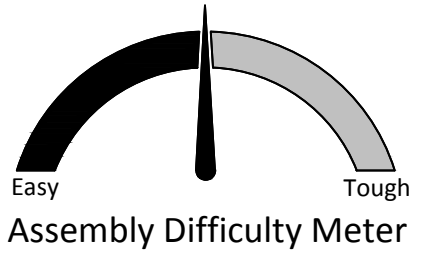

Follow Ameriwood Home



## Contact Us!

### Do NOT return this product!

Contact our friendly customer service team first for help.

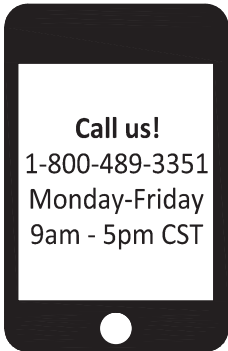

Visit [ameriwoodhome.com](http://ameriwoodhome.com)

Assembly Tips



## Helpful Hints

PEOPLE NEEDED FOR ASSEMBLY: **1-2**  
ESTIMATED ASSEMBLY TIME: **1 HOUR**

- Open your item in the area you plan to keep it to avoid excessive heavy lifting.
- Identify, sort and count the parts before attempting assembly.
- Compression dowels are lightly tapped in with a hammer.
- Slides are labeled with a **R** (right) and **L** (left) for proper placement.
- Make sure to always face the point on the top of the Cam Lock towards the outer edge.
- Use all the nails provided for the back panel and spread them out equally.
- Back panel must be used to make sure your unit is sturdy.
- Do NOT use harsh chemicals or abrasive cleaners on this item.
- Never push, pull, or drag your furniture.



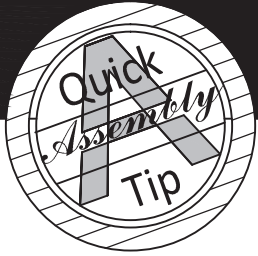

# Before You Start

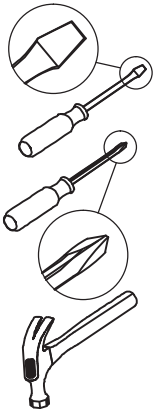

- ✓ Read through each step carefully and follow the proper order
- ✓ Separate and count all your parts and hardware
- ✓ Give yourself enough room for the assembly process
- ✓ Have the following tools: Flat Head Screwdriver, #2 Phillips Head Screwdriver and Hammer
- ✓ Caution: If using a power drill or power screwdriver for screwing, please be aware to slow down and stop when screw is tight. Failure to do so may result in stripping the screw.

# Cam Lock Fastening System

This Cam Lock Fastening System will be used throughout the assembly process.

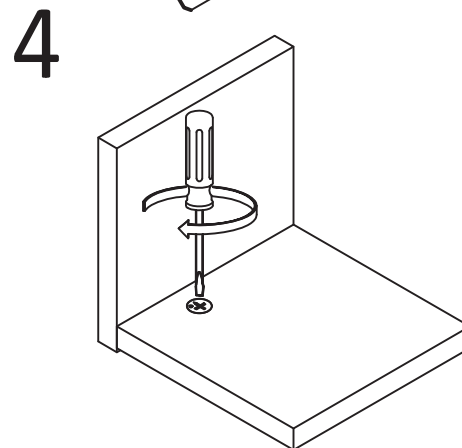
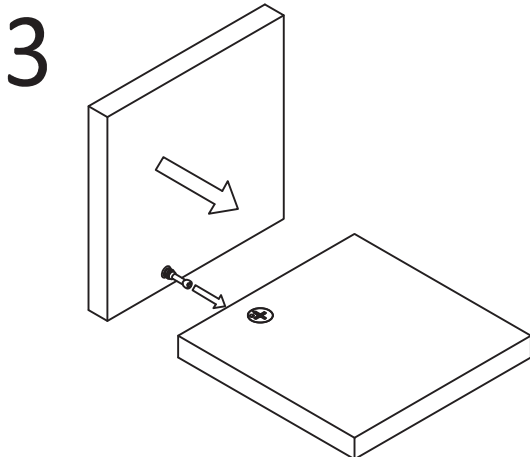
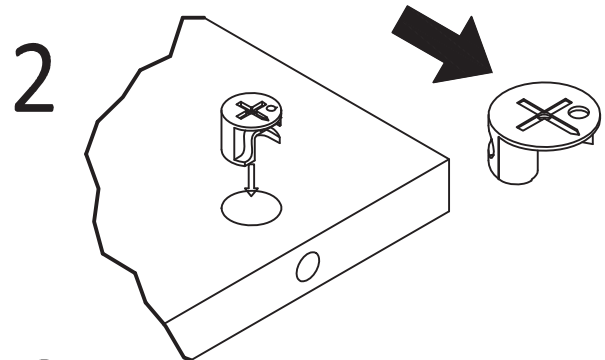
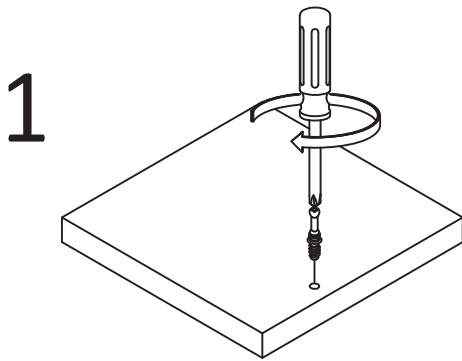

3

# Board Identification

Not actual size

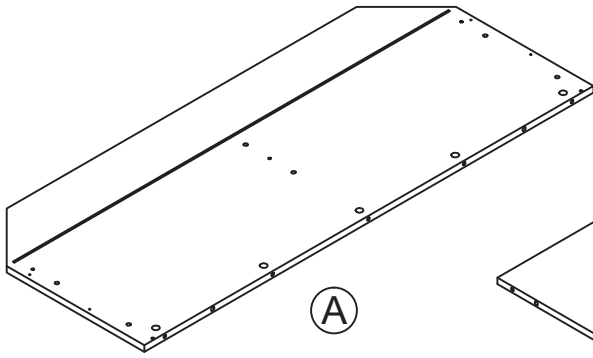

TOP  
T4917335010EL

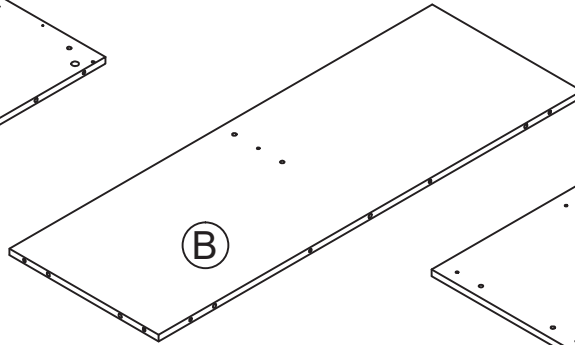

FIXED SHELF  
T4917335020EL

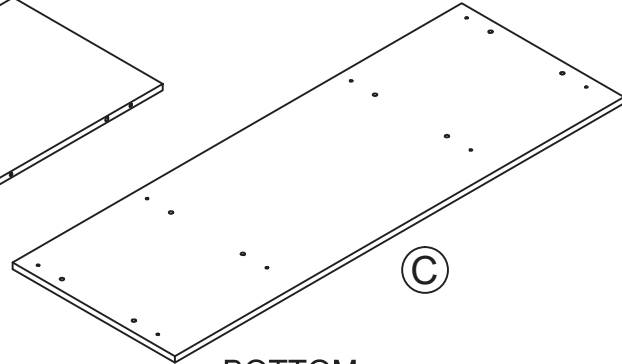

BOTTOM  
T4917335030EL

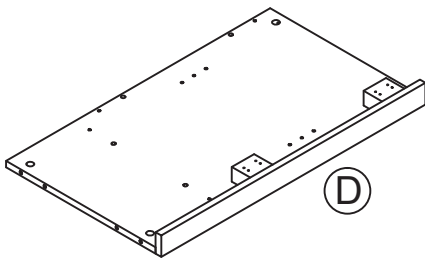

LEFT SIDE PANEL  
T4917335040EL

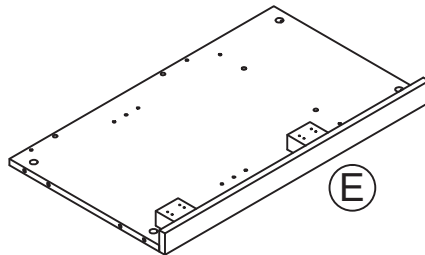

RIGHT SIDE PANEL  
T4917335050EL

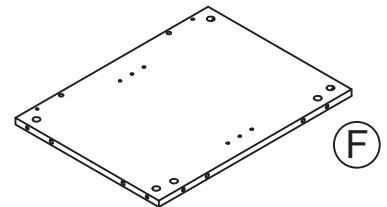

PARTITION  
T4917335060EL  
Qty:2

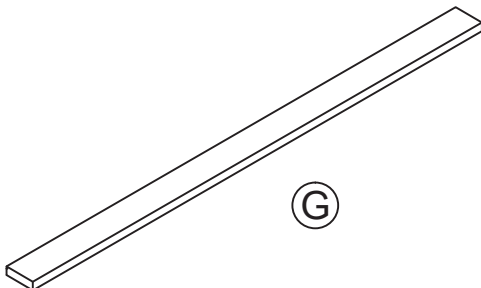

TOP FRONT RAIL  
T4917335070EL

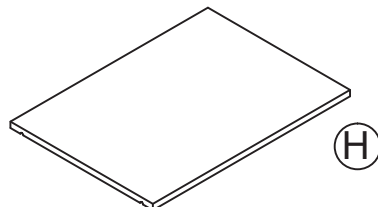

MIDDLE ADJUSTABLE SHELF  
T4917335080EL

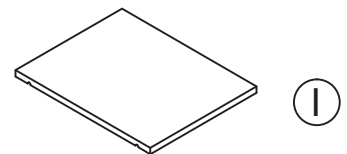

SIDE ADJUSTABLE SHELF  
T4917335090EL  
Qty:2

# Board Identification

Not actual size

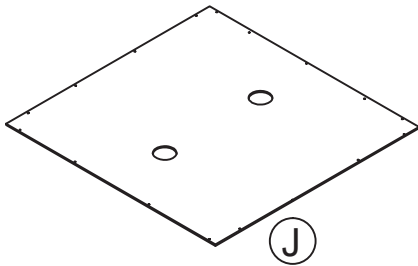

MIDDLE BACK PANEL  
T4917335100EL

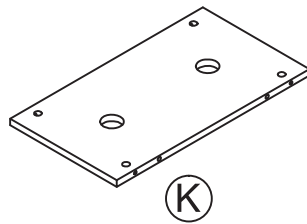

SIDE BACK PANEL  
T4917335110EL  
Qty:2

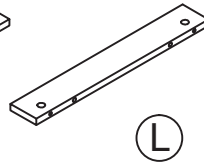

MIDDLE RAIL  
T4917335120EL

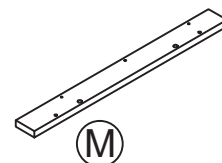

LEFT RAIL  
T4917335130EL

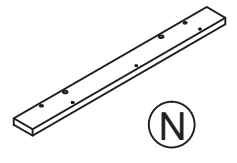

RIGHT RAIL  
T4917335140EL

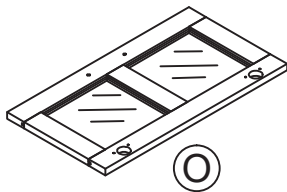

DOOR  
T4917335150EL  
Qty:2

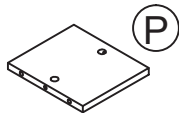

UPPER PARTITION  
T4917335160EL

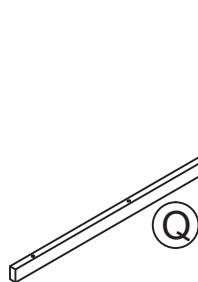

UPPER RAIL  
T4917335170EL

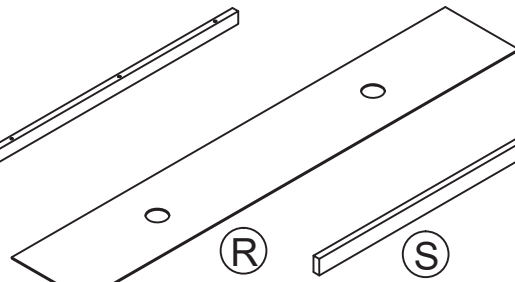

UPPER BACK PANEL  
T4917335180EL

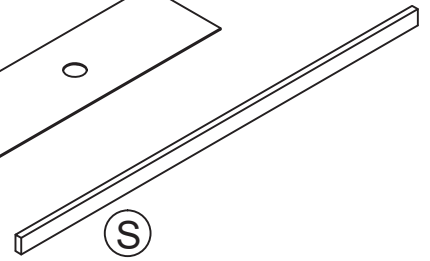

FIXED SHELF RAIL  
T4917335190EL

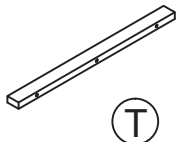

TOP END RAIL  
T4917335200EL  
Qty:2

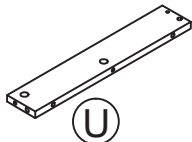

BOTTOM LEFT RAIL  
T4917335210EL

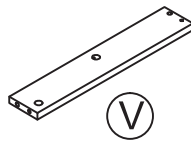

BOTTOM RIGHT RAIL  
T4917335220EL

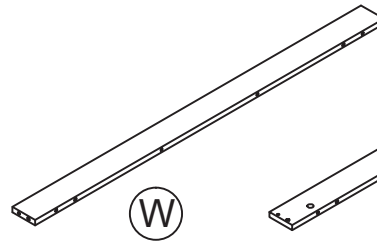

BOTTOM BACK RAIL  
T4917335230EL

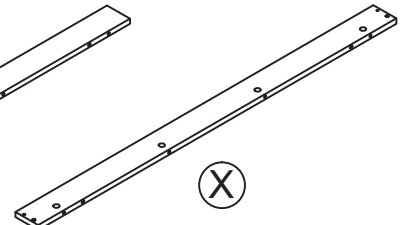

BOTTOM FRONT RAIL  
T4917335240EL

# Board Identification

Not actual size

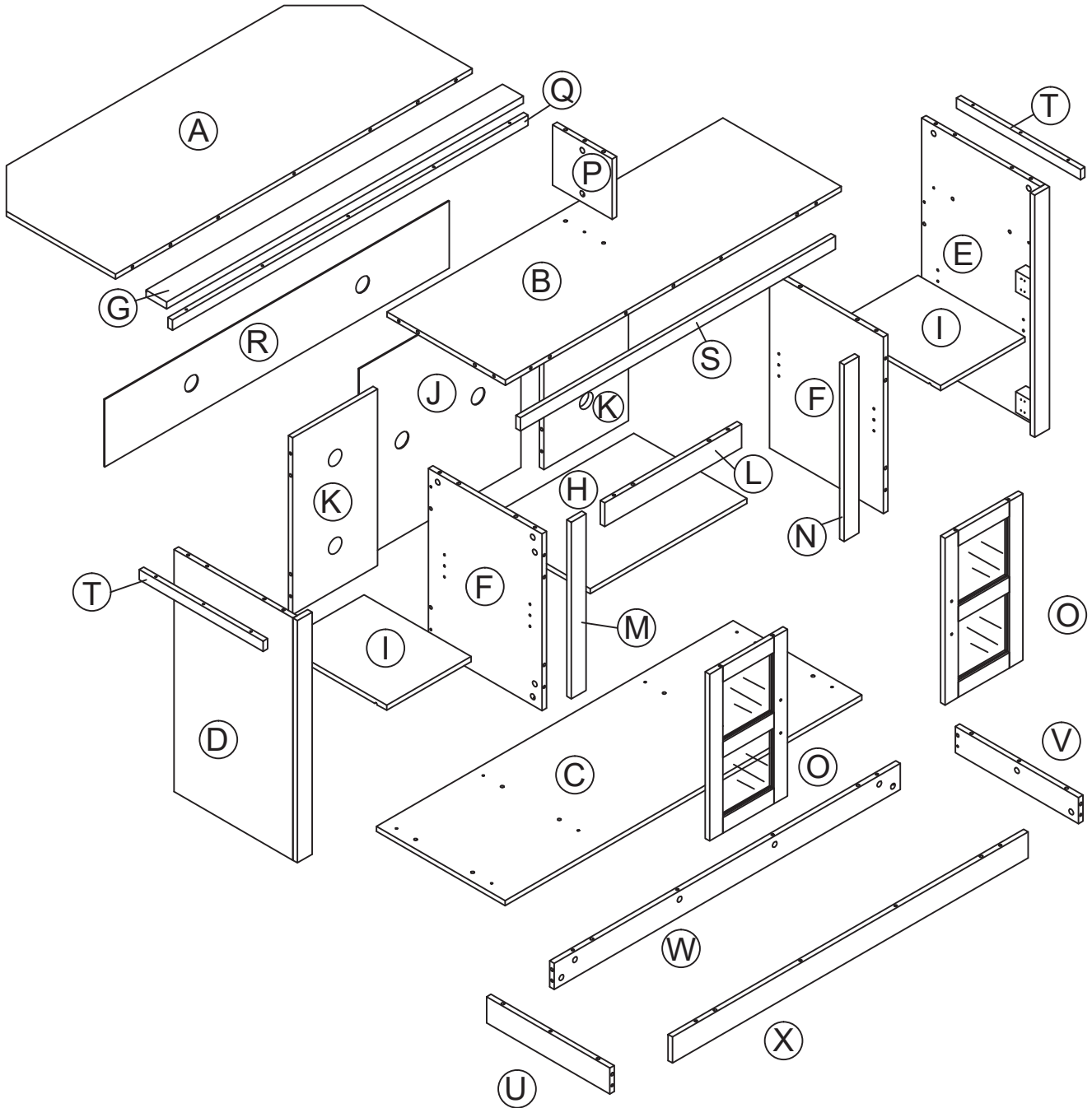

# Part List

Actual Size



φ6.5X35mm

②

X59

CAM BOLT  
TEL5101  
spare:2



φ8X30mm

③

X55

WOOD DOWEL  
TEL8002  
spare:2



φ4X35mm

④

X11

SCREW  
TEL4204  
spare:1

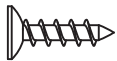

Ø3.5\*14mm

⑥

X24

SCREW  
TEL4404  
spare:1



Ø5/32X18mm

⑦

X4

BOLT  
TEL4026

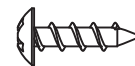

Ø4\*14mm

⑩

X8

SCREW  
TEL4036  
spare:1

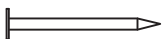

Ø1.5\*20mm

⑫

X22

NAIL  
TEL4703  
spare:2

# Part List

Not Actual Size

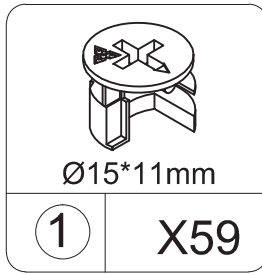

CAM LOCK  
TEL5001  
spare:2

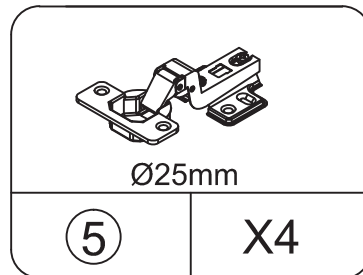

HINGE  
TEL3017

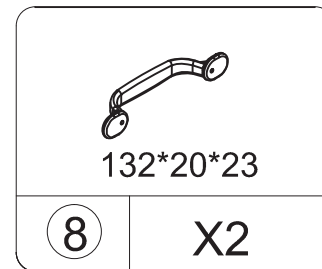

HANDLE  
TEL1029

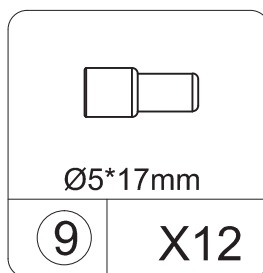

SHELF SUPPORT  
TEL6001  
spare:1

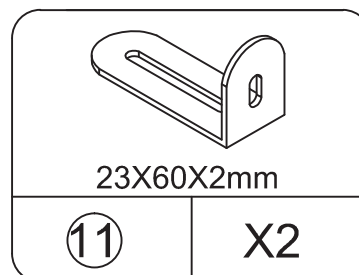

WALL BRACKET  
TEL9011

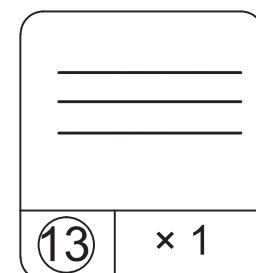

WARNING LABEL  
TEL4917



## STEP 1

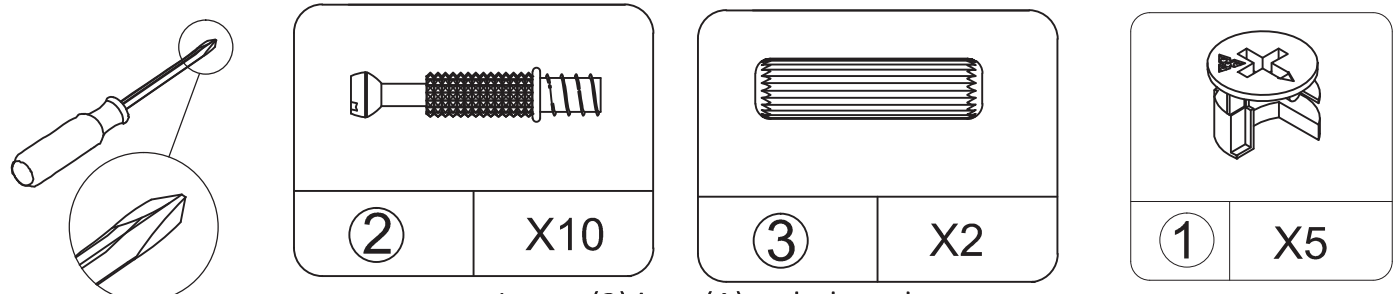

- Insert (3) into (A) as below shown.
- Screw (2) into (A) & (G) as below shown.
- Attach (G) to (A) as below shown.

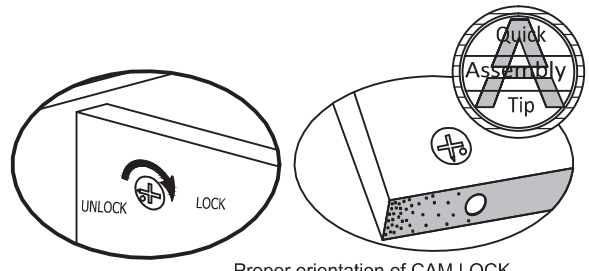
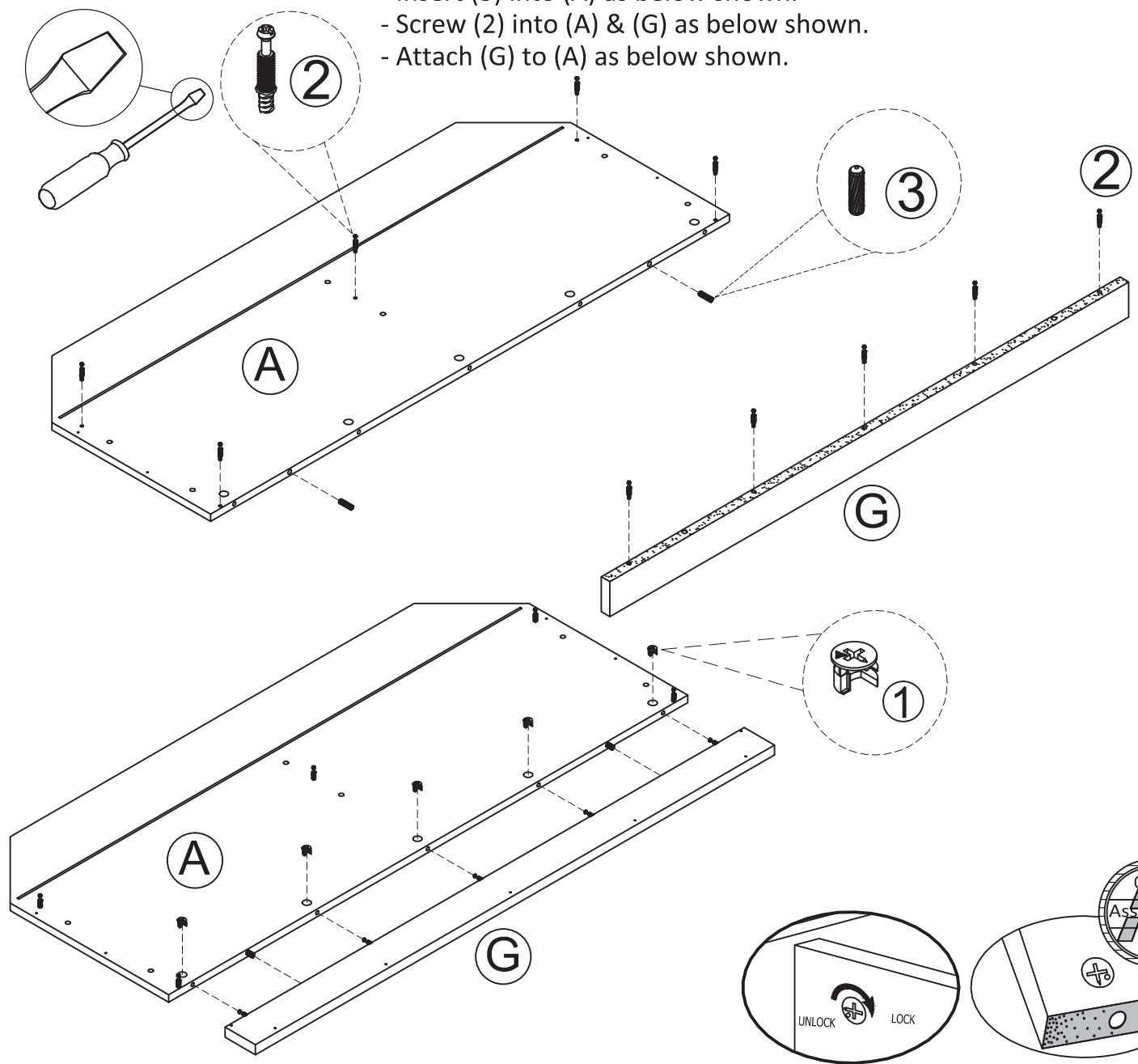

Proper orientation of CAM LOCK

\* raw edges are shaded

## STEP 2

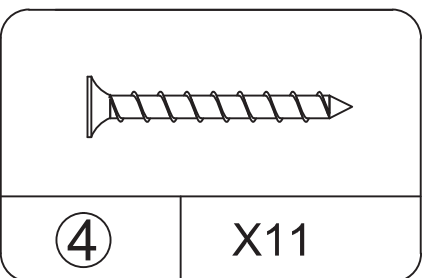
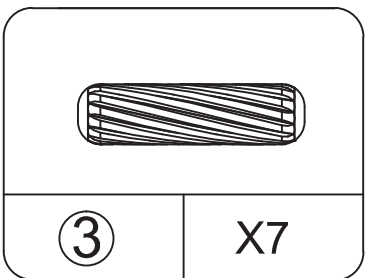
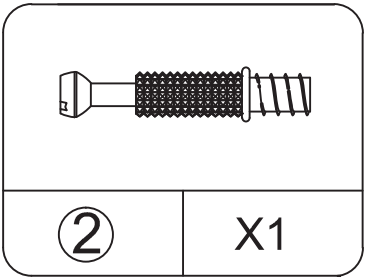
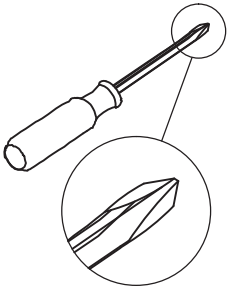

- Attach (T) & (Q) to (A) as below shown.  
 - Insert (3) into (B) as below shown.

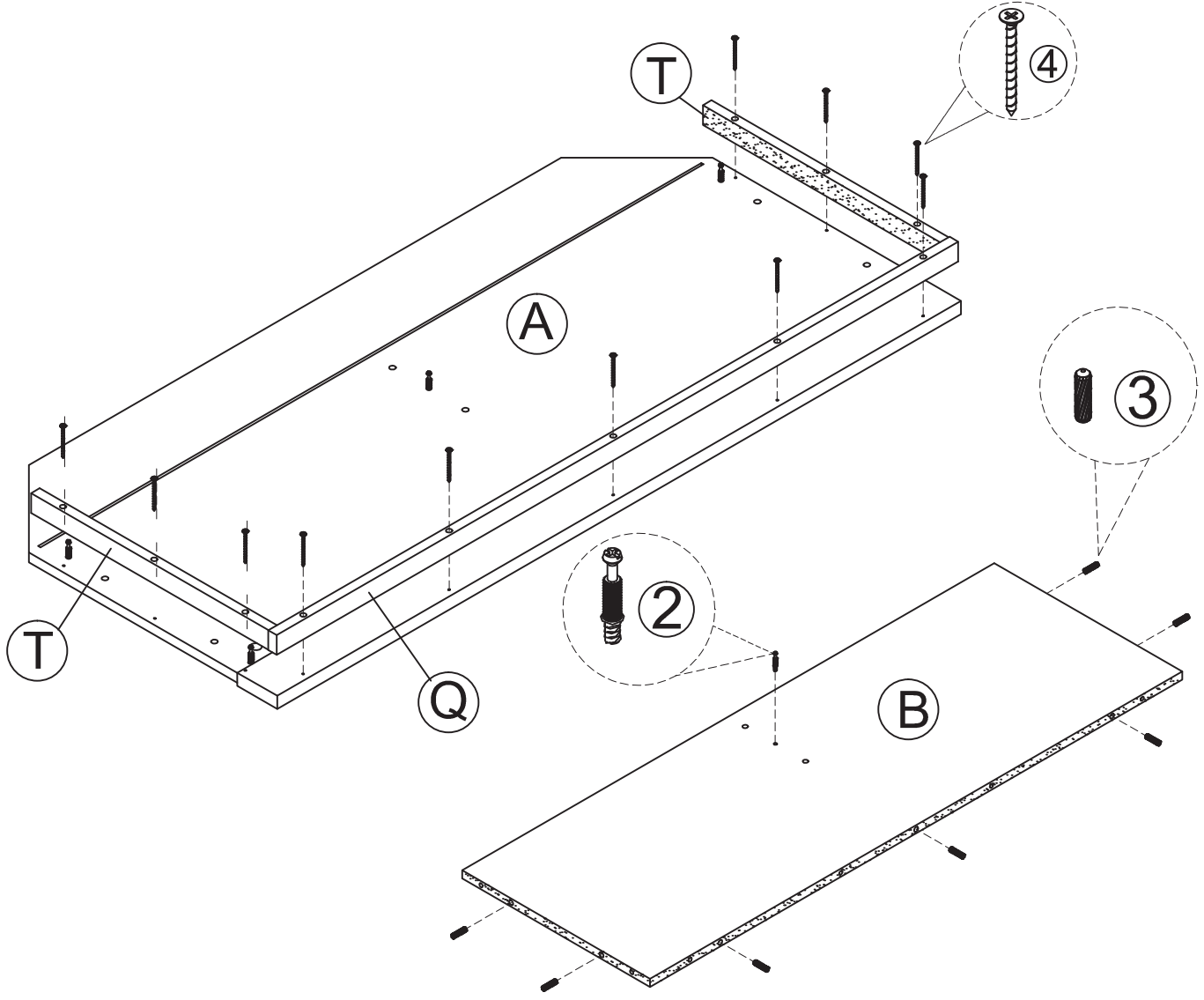

## STEP 3

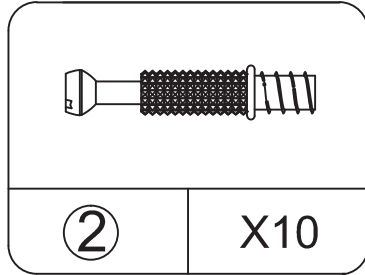
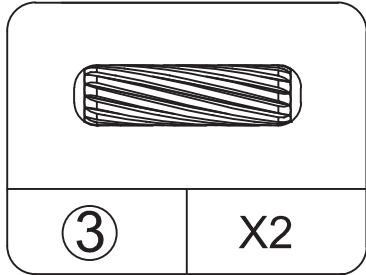
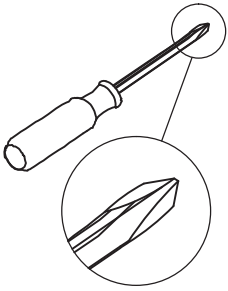

- Insert (3) into (L) as below shown.
- Screw (2) into (B) & (S) as below shown.

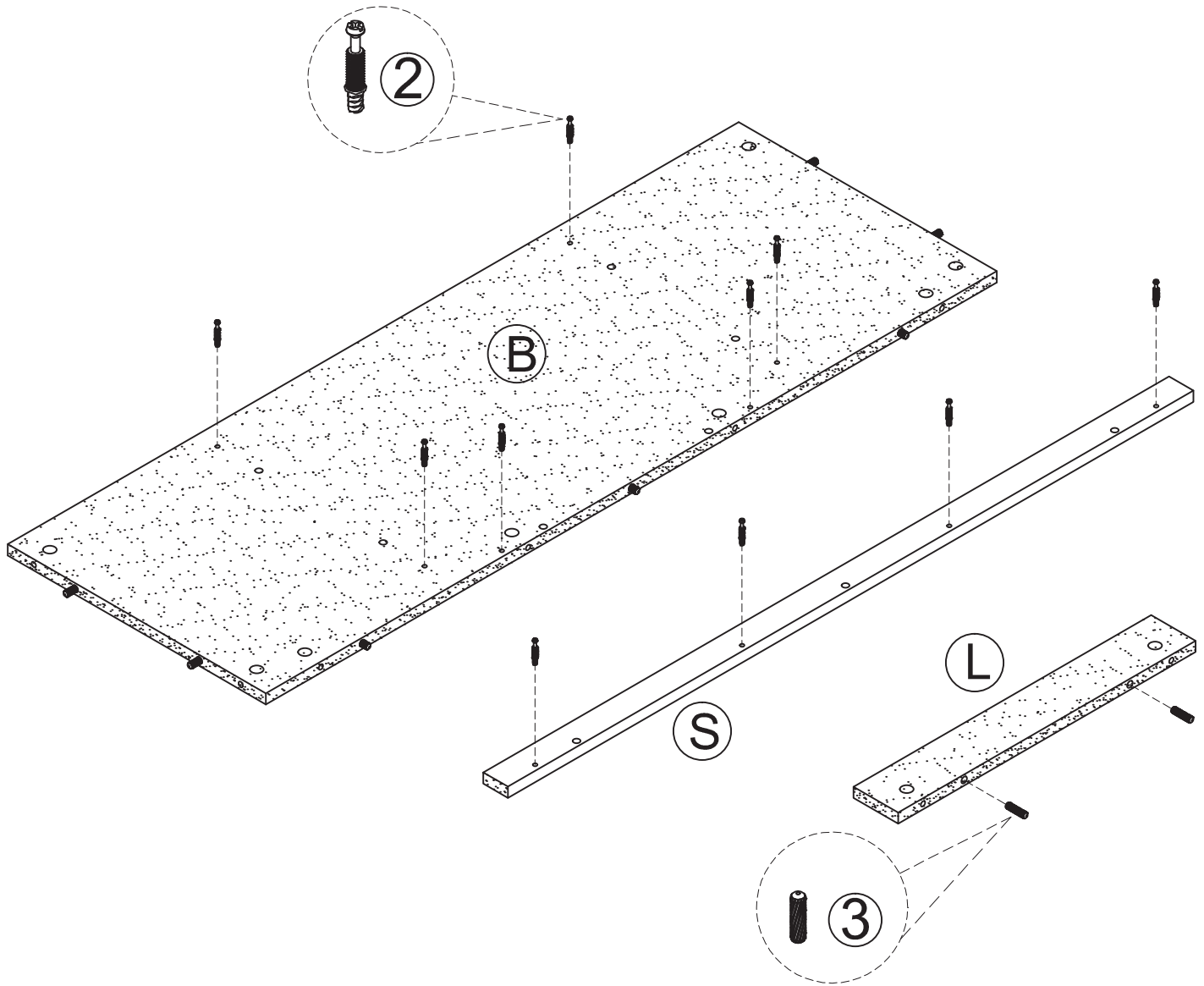

\* raw edges are shaded

## STEP 4

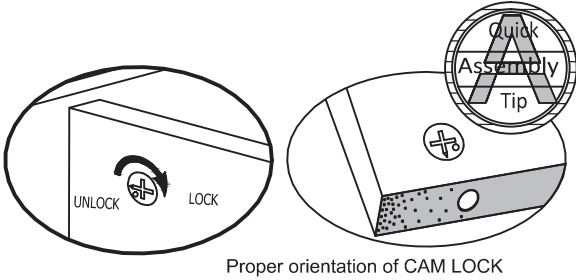
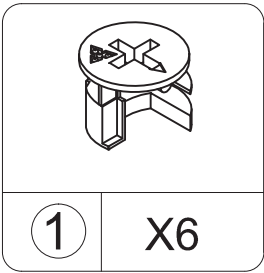
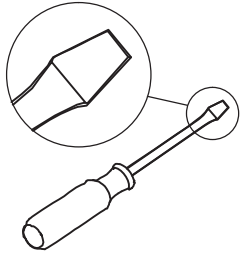

Proper orientation of CAM LOCK

- Attach (L) & (S) to (B) as below shown.

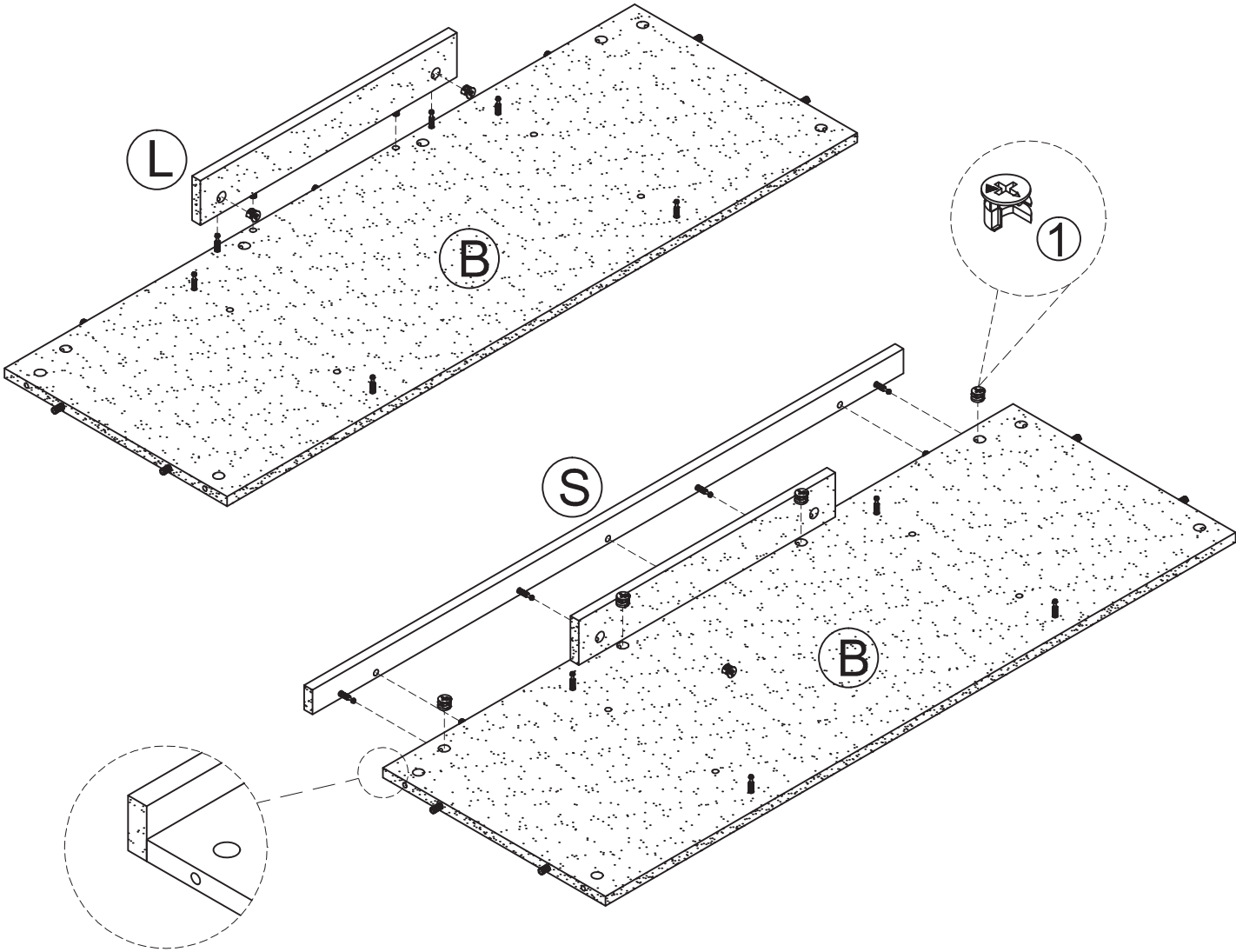

\* raw edges are shaded

## STEP 5

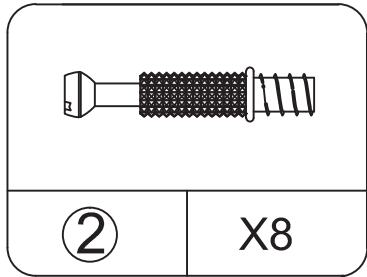
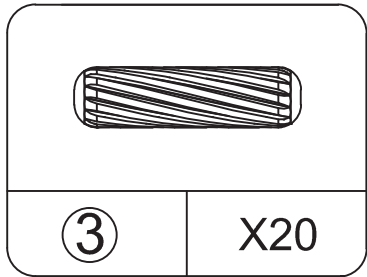
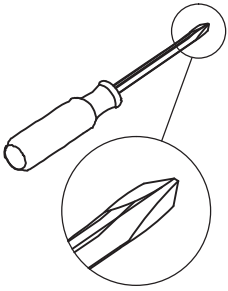

- Insert (3) into (D) & (E) & (P) & (K) as below shown.
- Screw (2) into (D) & (E) as below shown.

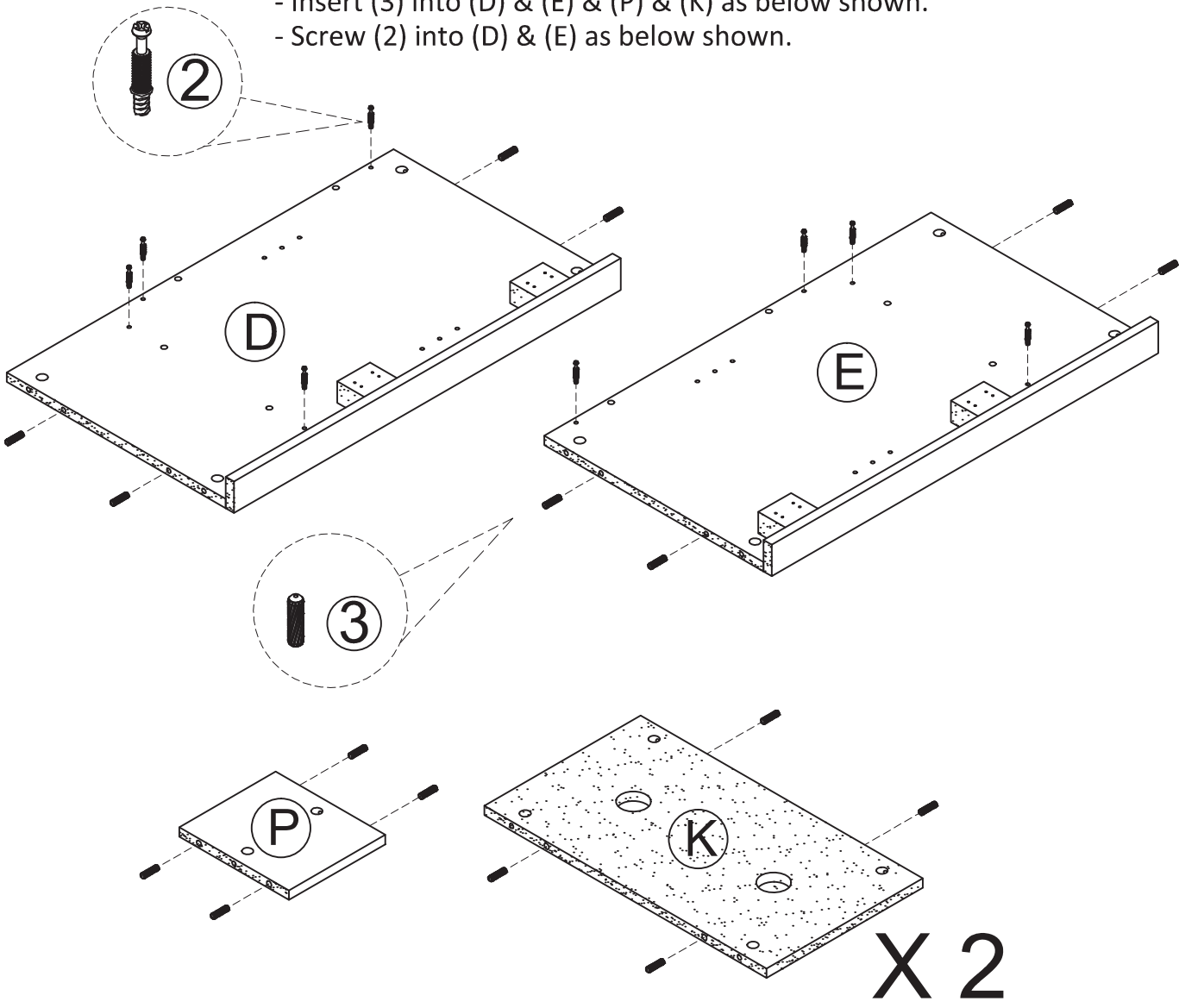

## STEP 6

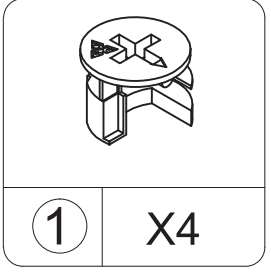
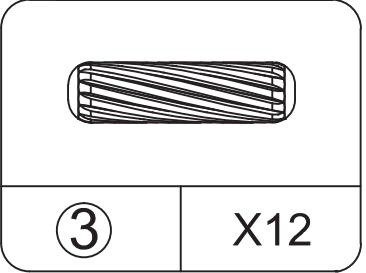
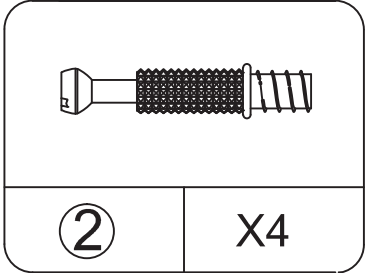
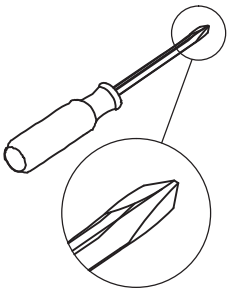

- Insert (3) into (F) as below shown.
- Screw (2) into (M) & (N) as below shown.
- Attach (M) & (N) to (F) as below shown.

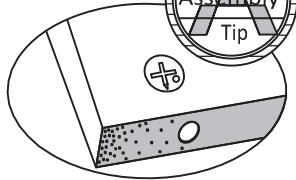
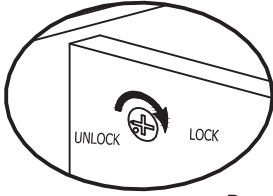

Proper orientation of CAM LOCK

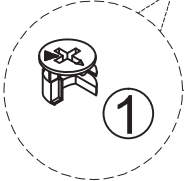
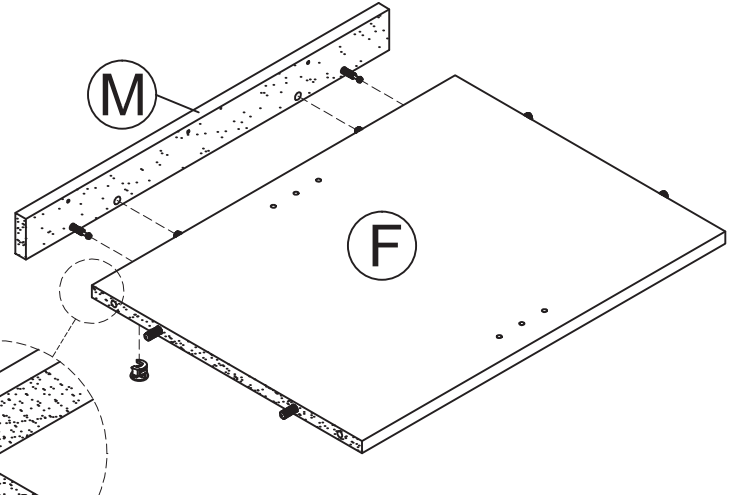
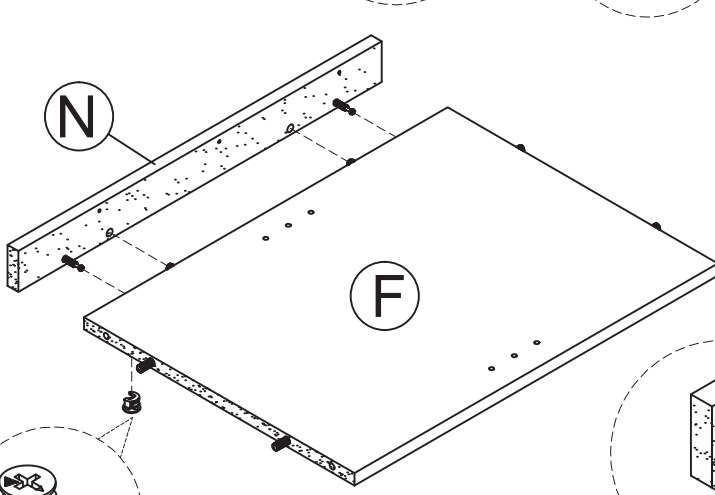
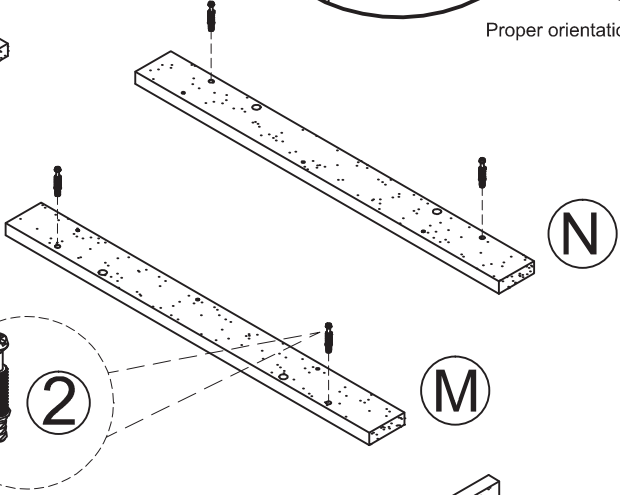
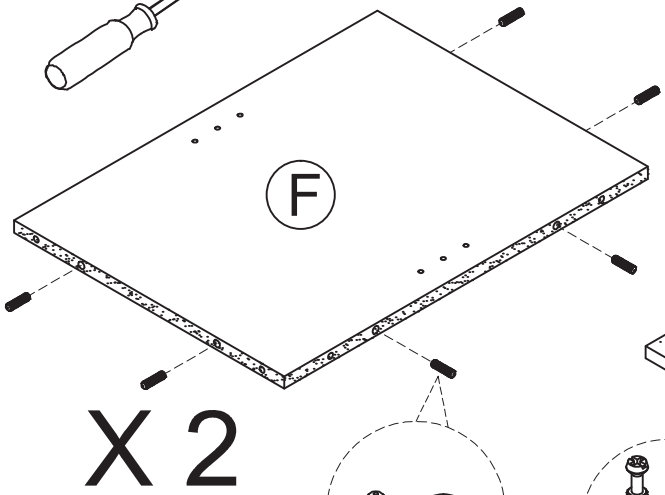

\* raw edges are shaded

## STEP 7

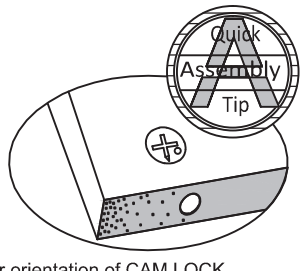
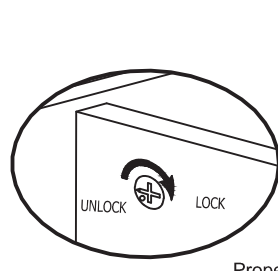
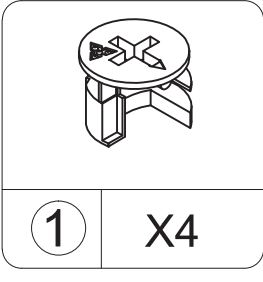
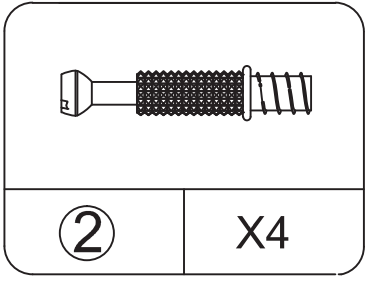
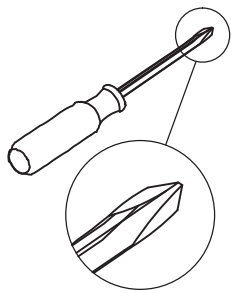

Proper orientation of CAM LOCK

- Screw (2) into (F) as below shown.
- Attach (K) to (F) as below shown.

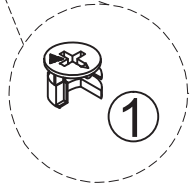
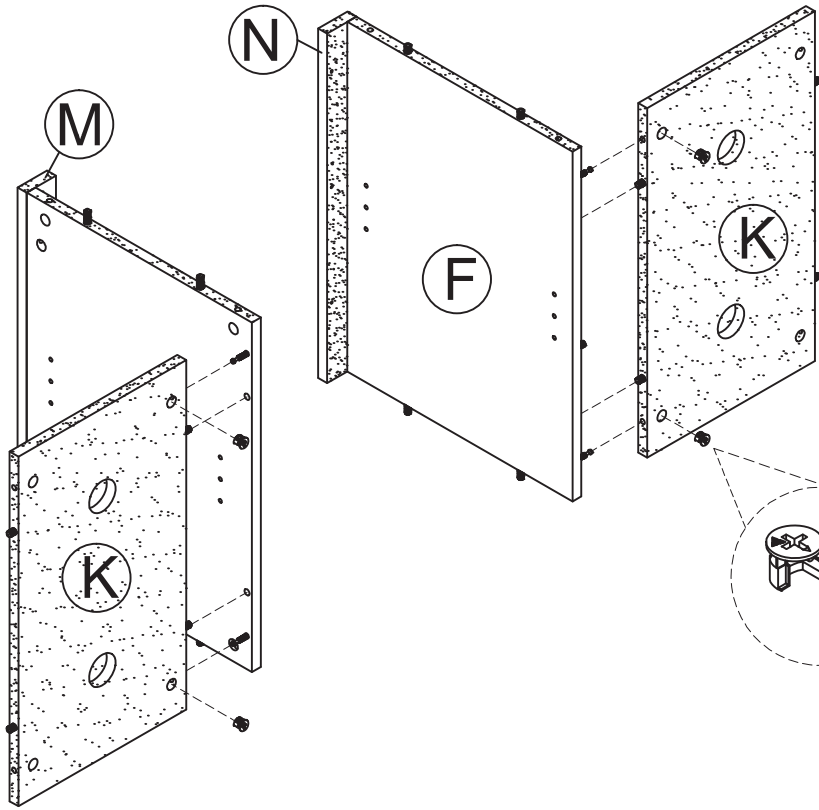
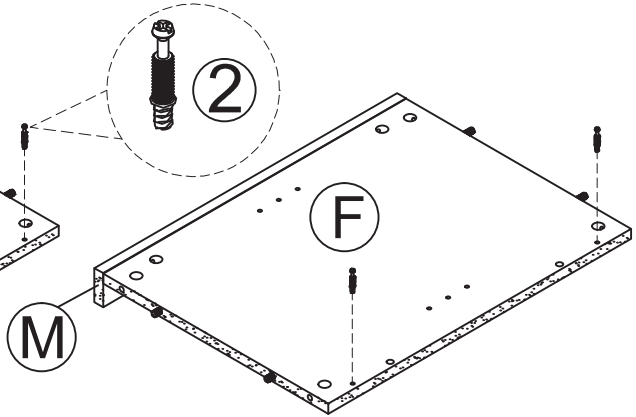
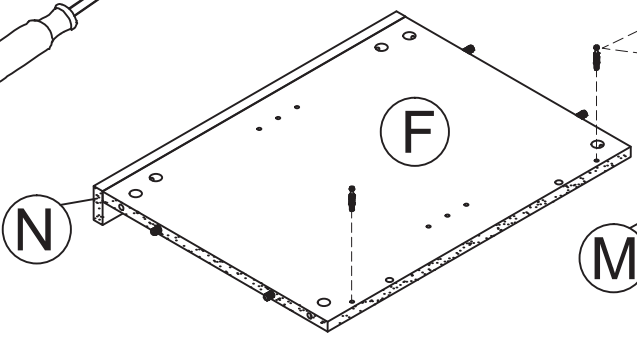
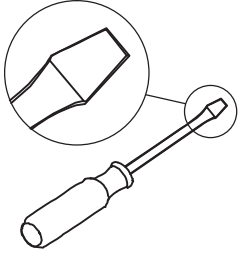

\* raw edges are shaded

## STEP 8

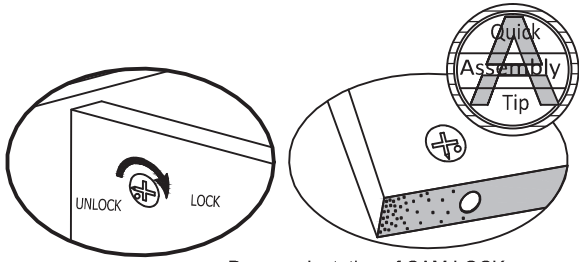
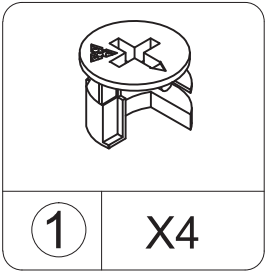
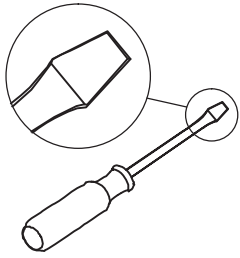

- Attach (F) to (B) as below shown.

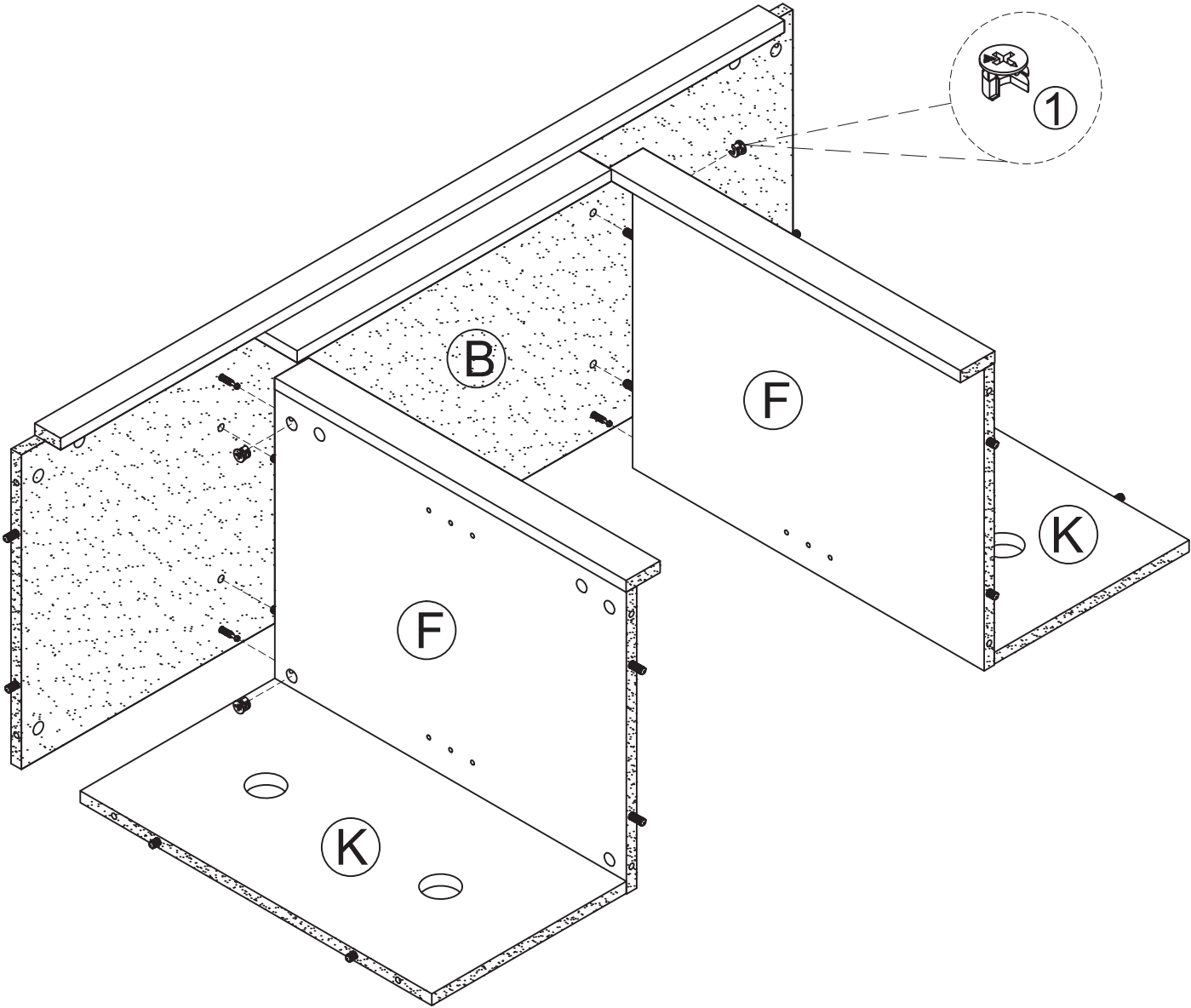

\* raw edges are shaded



# STEP 9

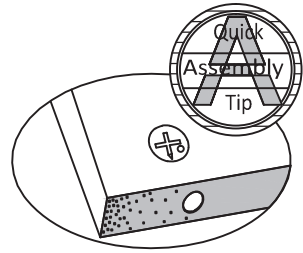
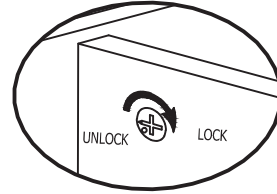
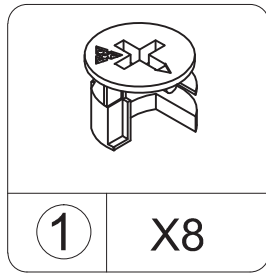
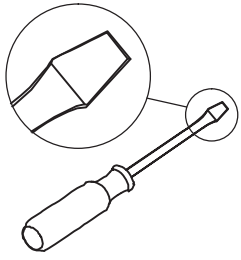

Proper orientation of CAM LOCK

- Attach (D) & (E) to pre-assembled unit as below shown.

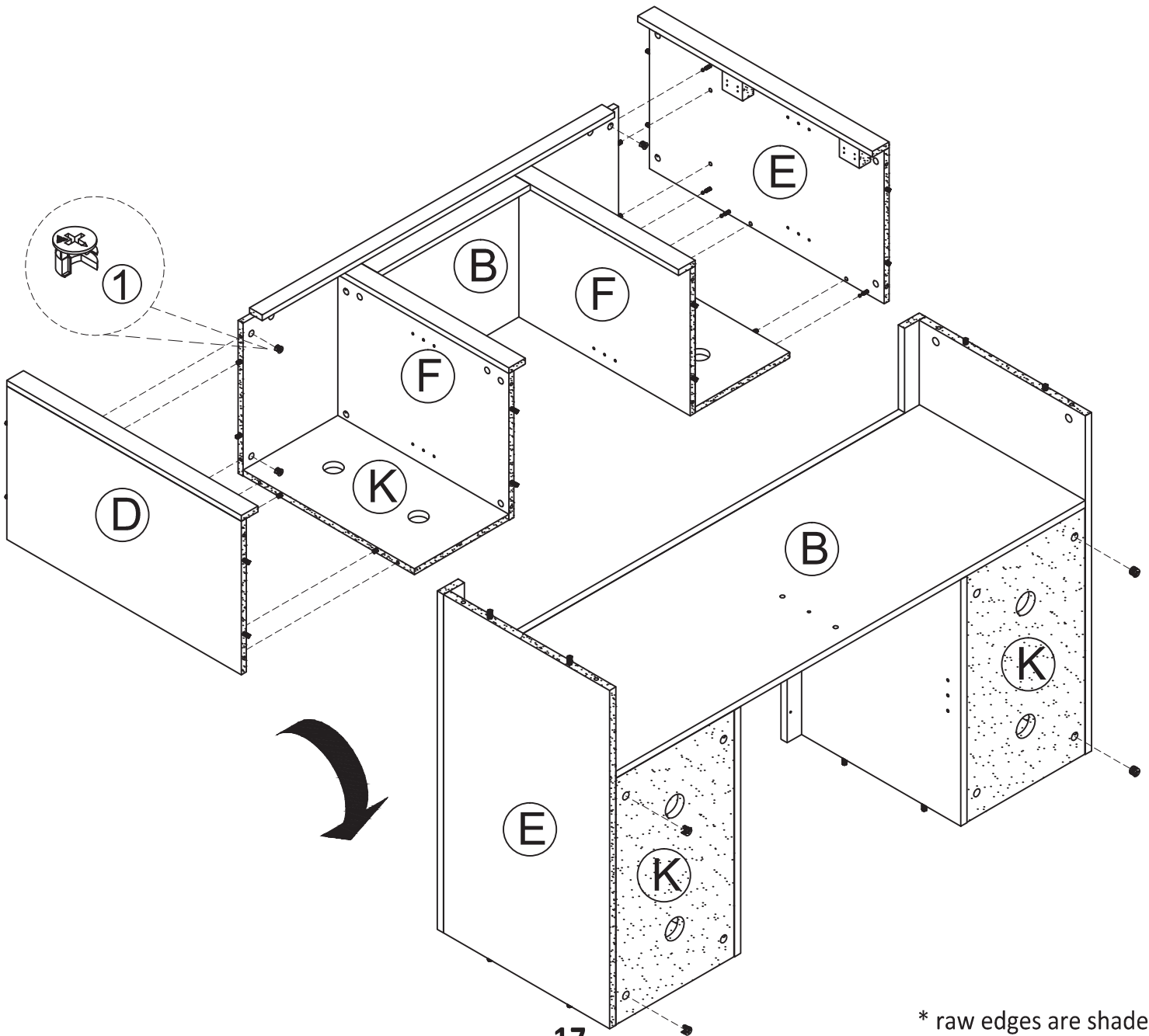

\* raw edges are shaded

## STEP 10

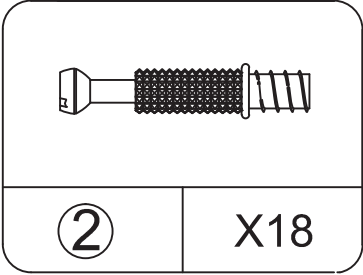
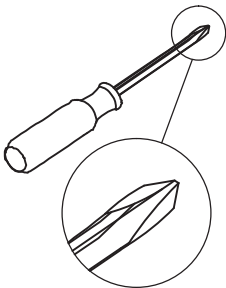

- Screw (2) into (C) as below shown.

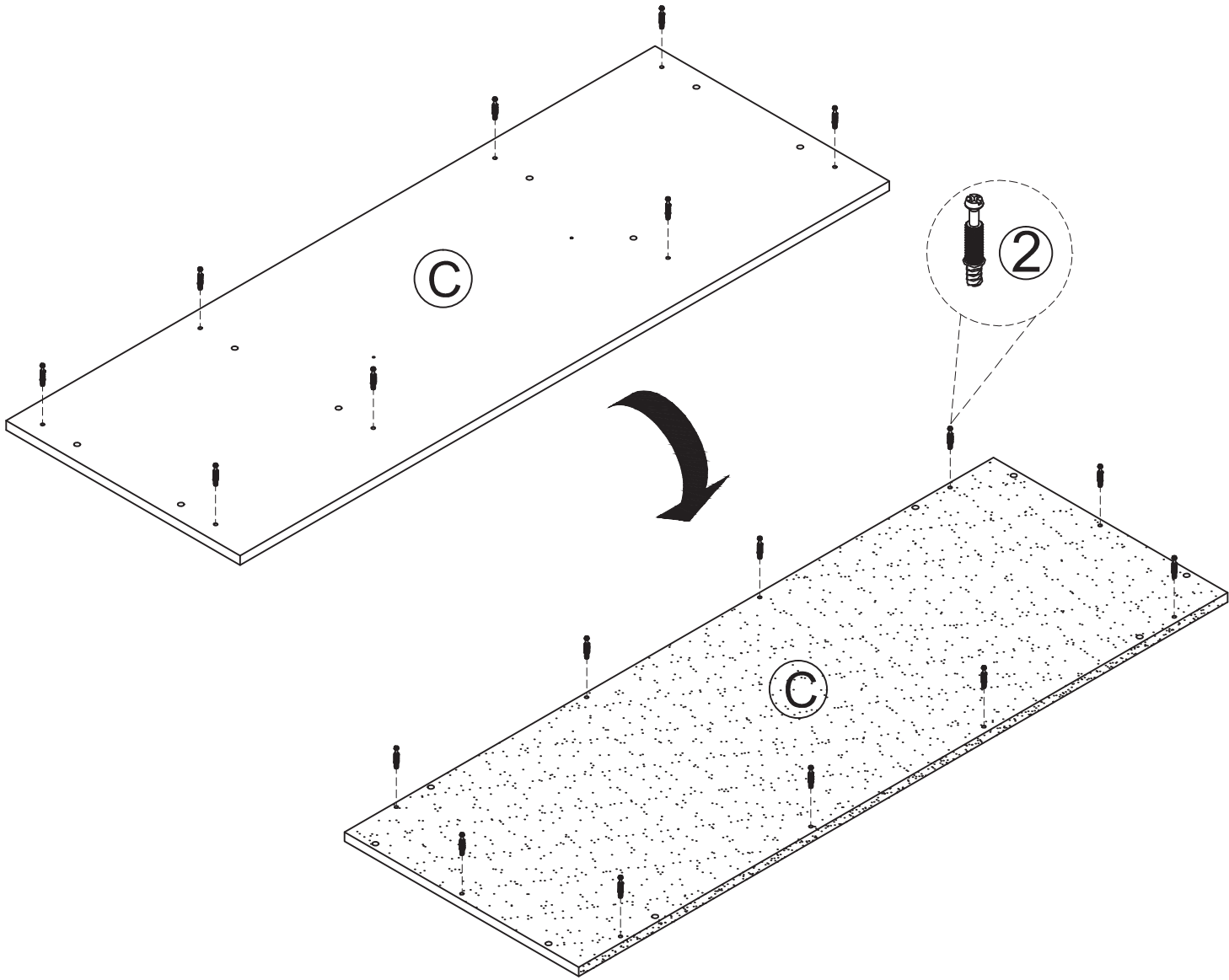

\* raw edges are shaded

## STEP 11

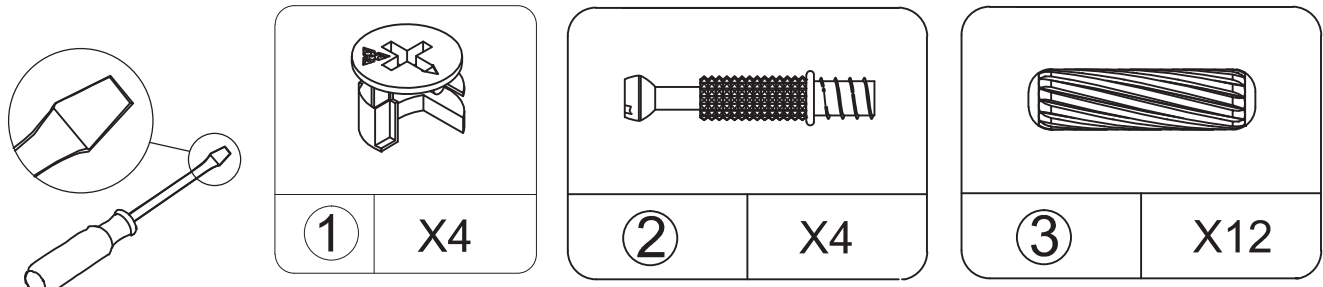

- Insert (3) into (U) & (V) & (W) & (X) as below shown.
- Screw (2) into (U) & (V) & (W) & (X) as below shown.
- Attach (U) & (V) to (W) & (X) as below shown.

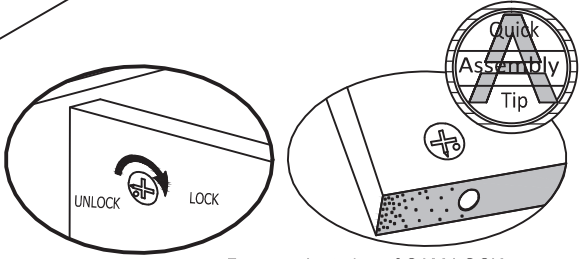
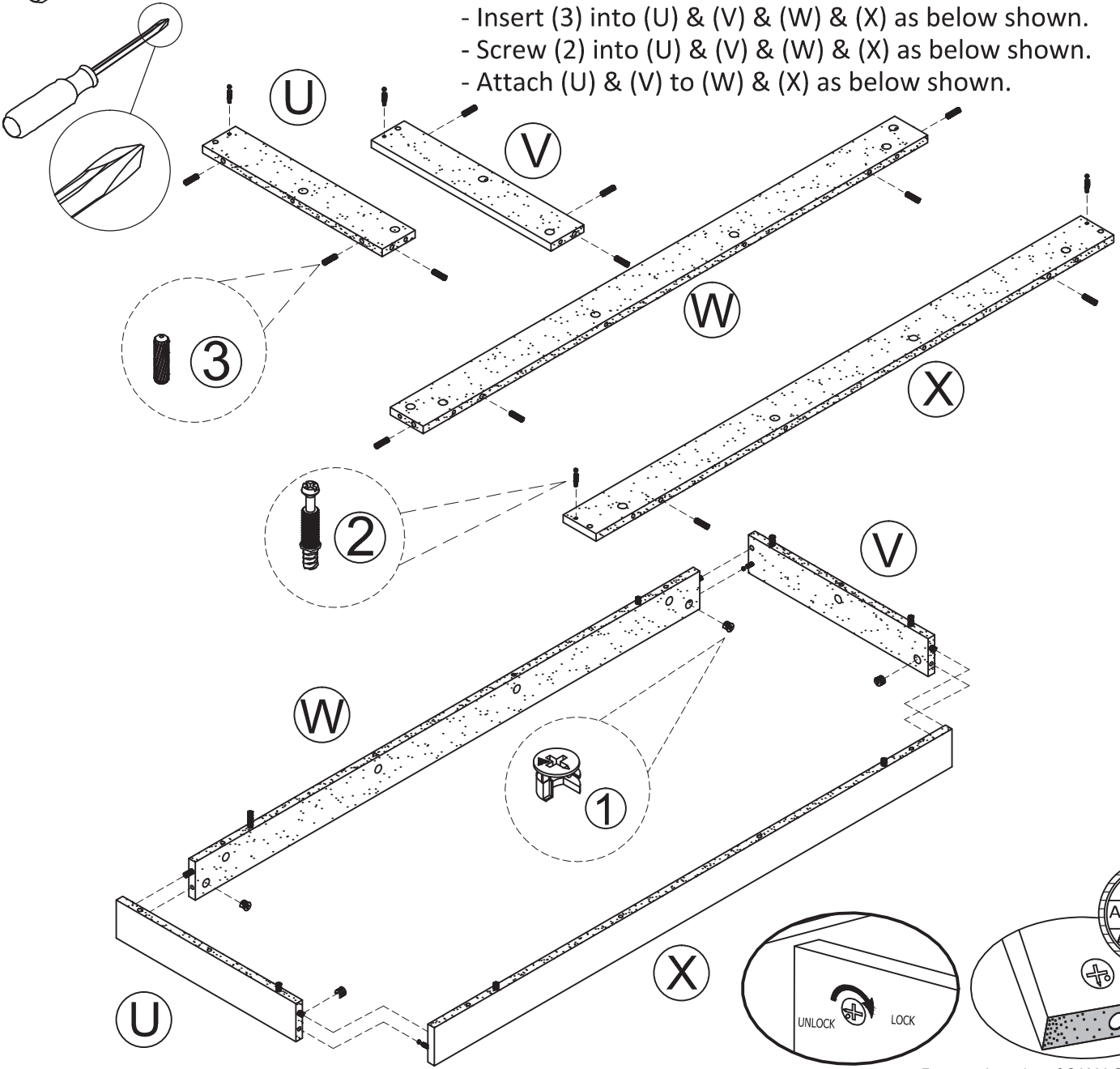

\* raw edges are shaded

## STEP 12

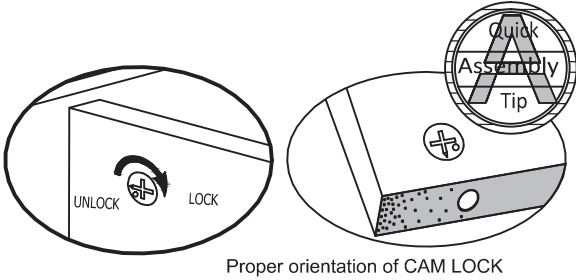
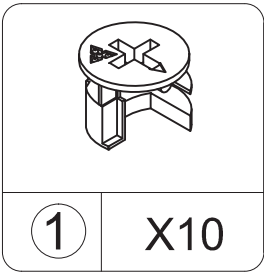
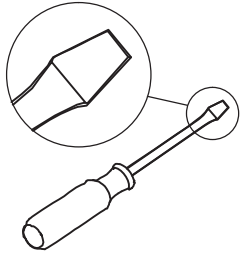

- Attach (U) & (V) & (W) & (X) to (C) as below shown.

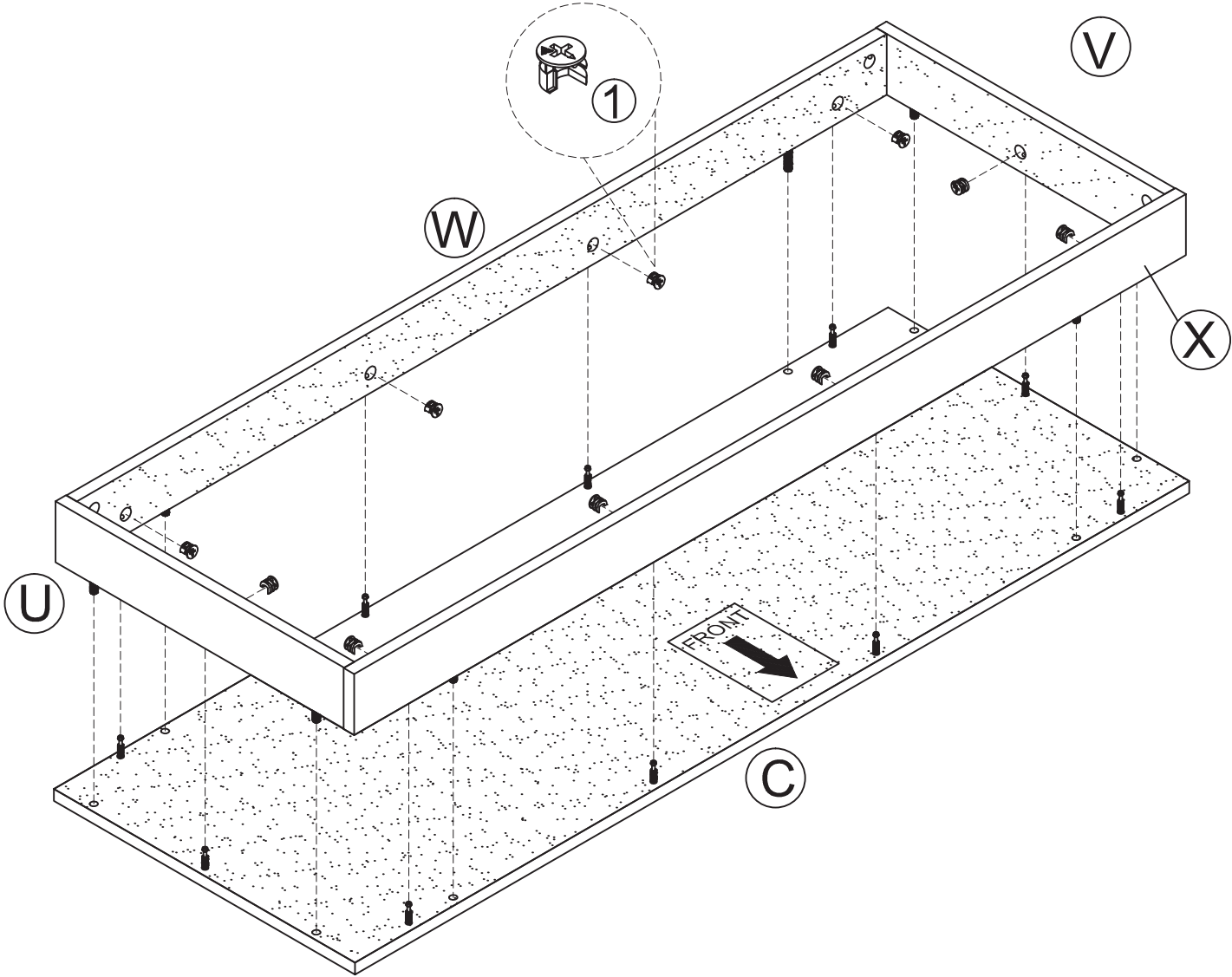

\* raw edges are shaded

## STEP 13

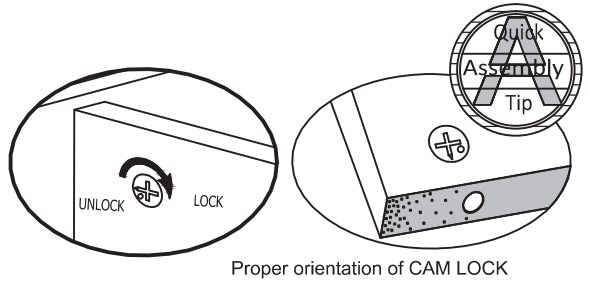
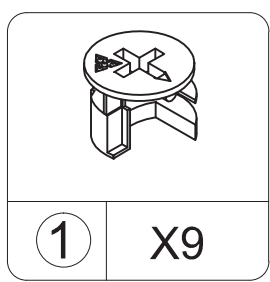
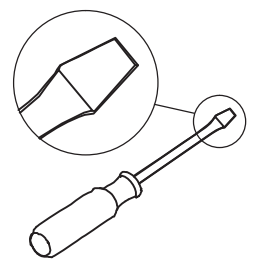

Proper orientation of CAM LOCK

- Attach (C) & (P) to pre-assembled unit as below shown.

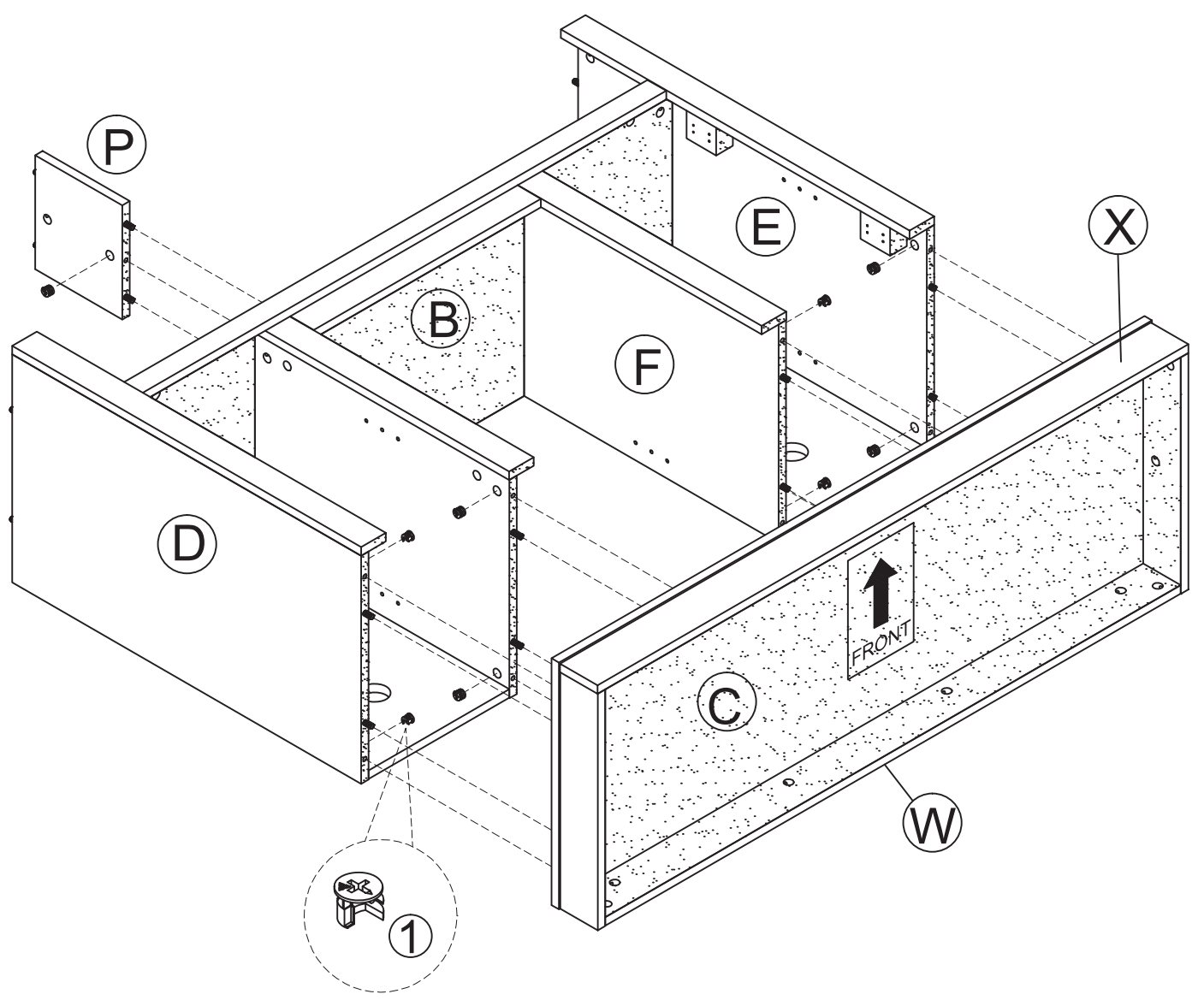

\* raw edges are shaded

## STEP 14

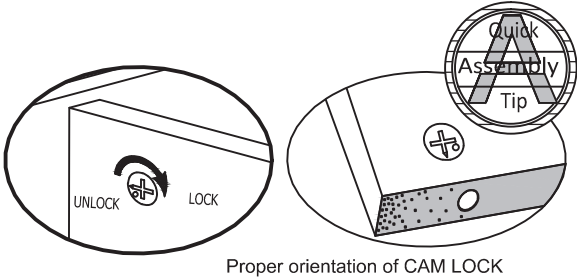
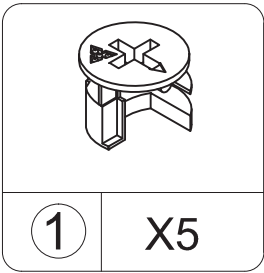
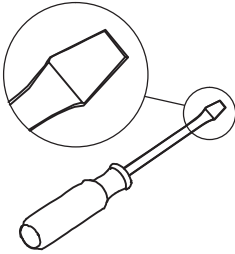

- Attach (A) to pre-assembled unit as below shown.

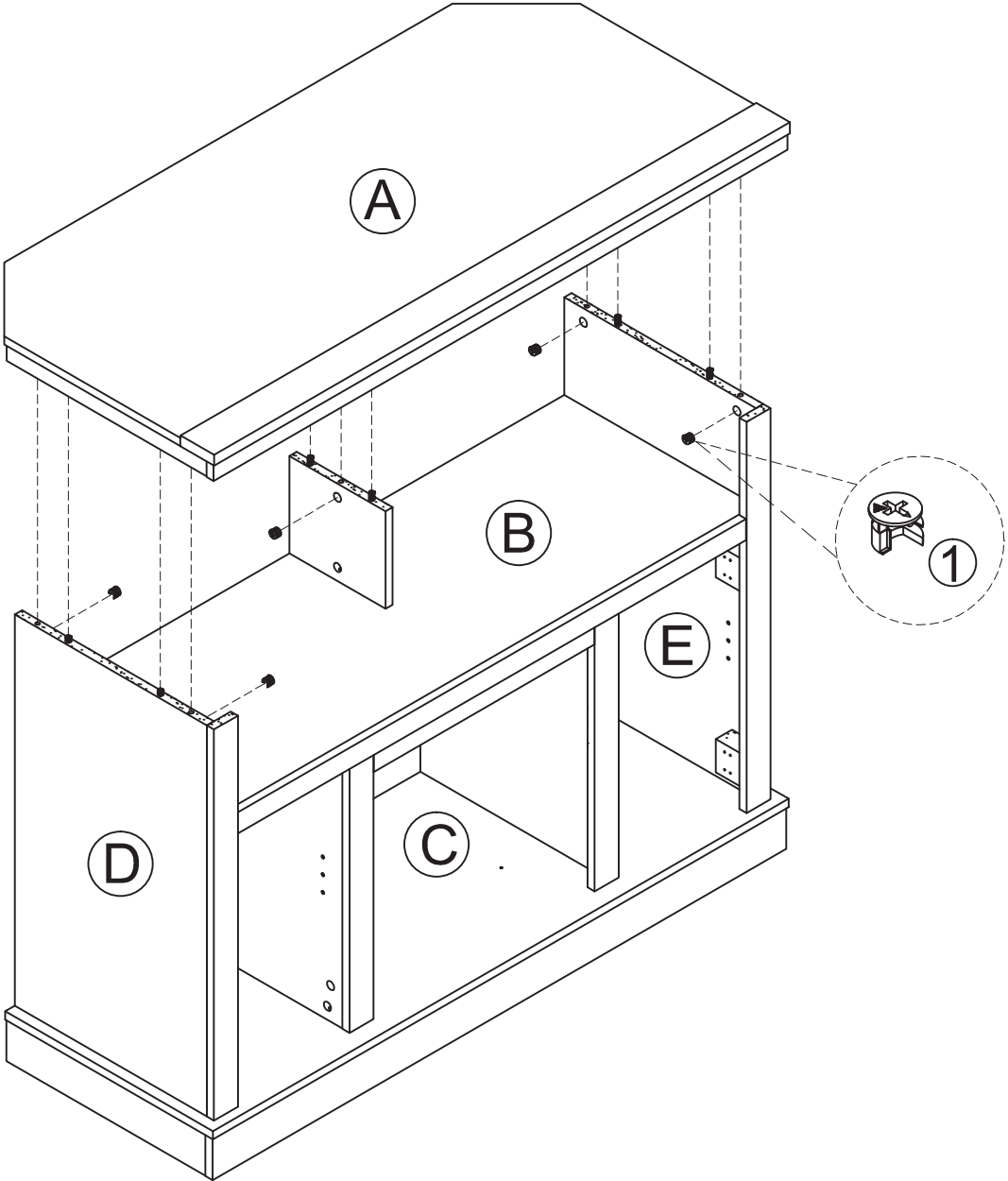

\* raw edges are shaded

If you purchased the the fireplace insert, skip this step and proceed to step 18

## STEP 15

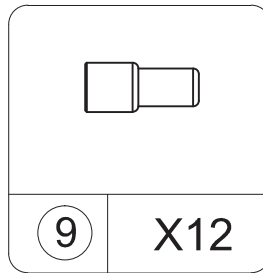
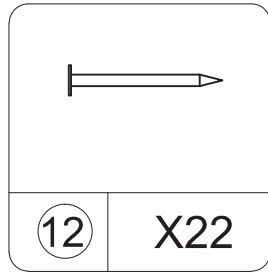
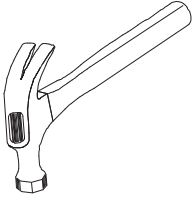

**IMPORTANT! THE BACK PANEL IS A STRUCTURAL PART OF THIS UNIT AND MUST BE INSTALLED PROPERLY.**

- Attach (R) to pre-assembled unit as below shown.

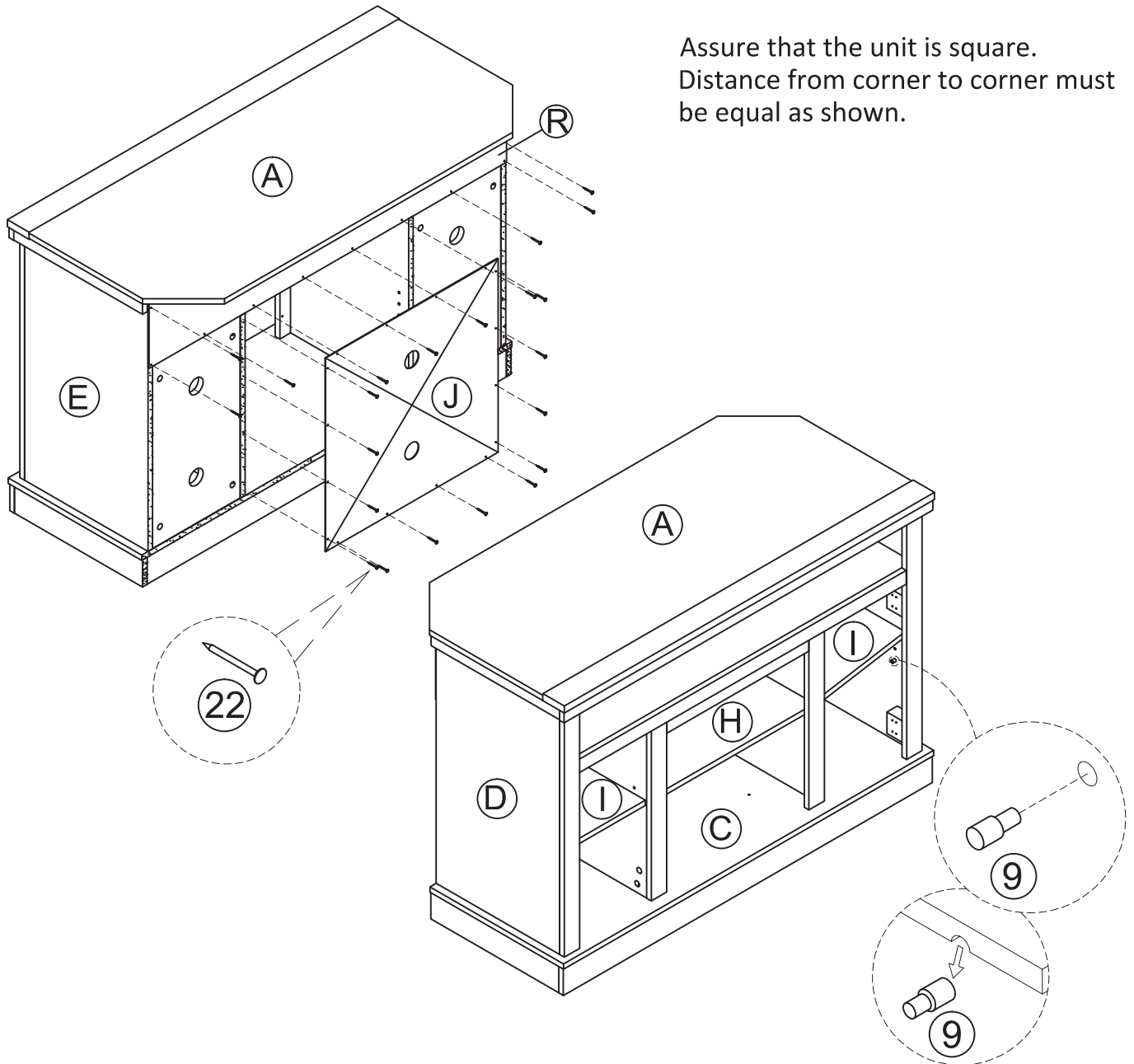

Assure that the unit is square. Distance from corner to corner must be equal as shown.

\* raw edges are shaded

## STEP 16

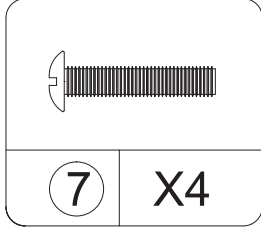
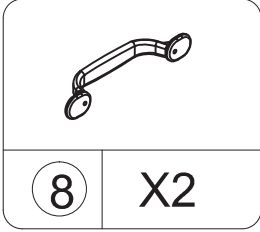
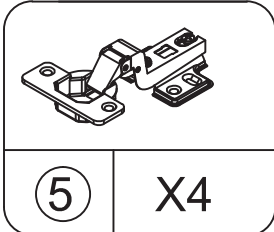
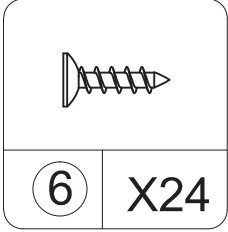
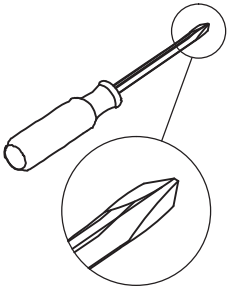

- Attach (O) to (D) & (E) as below shown.

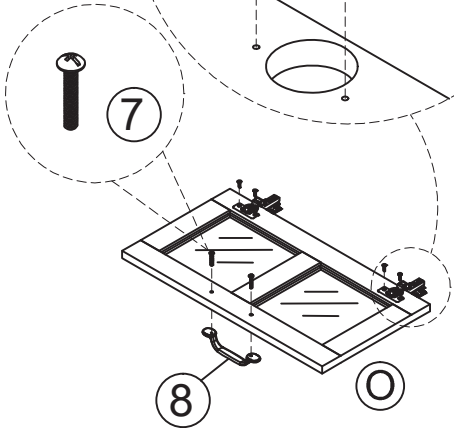
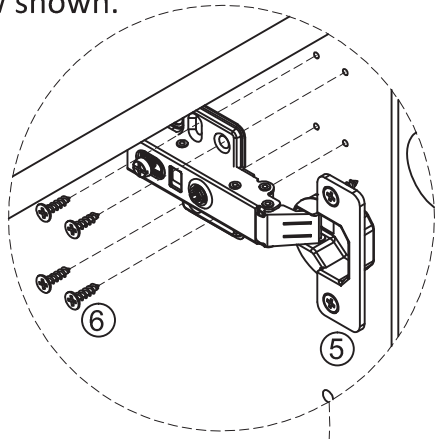
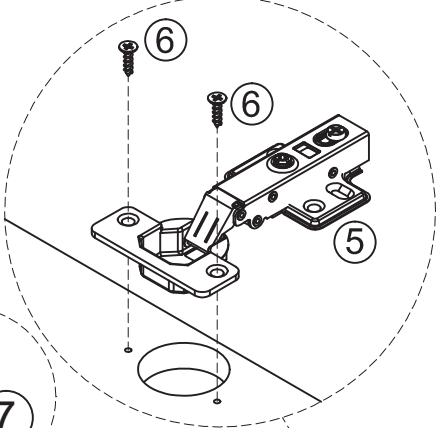

X 2

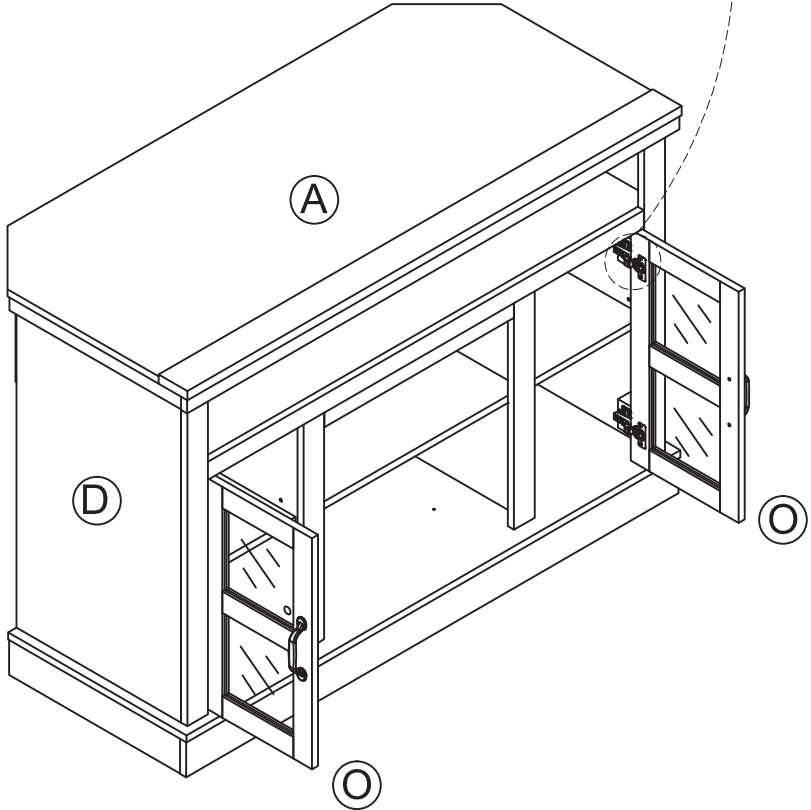

\* raw edges are shaded



# STEP 17

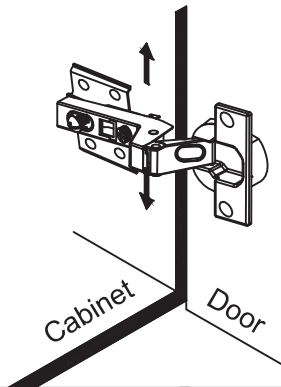
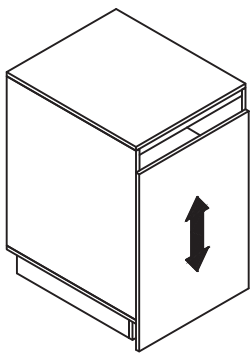
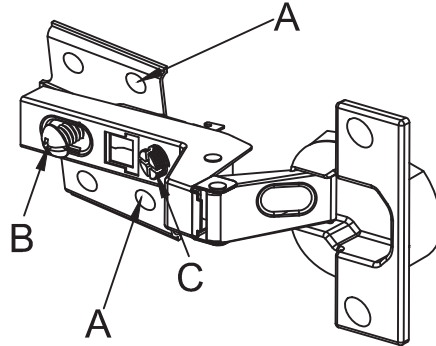

### To adjust the vertical height.

Loosen the four screws "A" on both hinges. Two of them are usually in slotted holes which allows you to adjust up or down by a few mm. Then tighten back up.

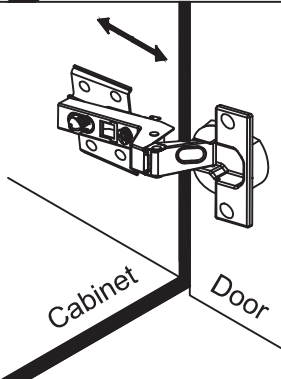
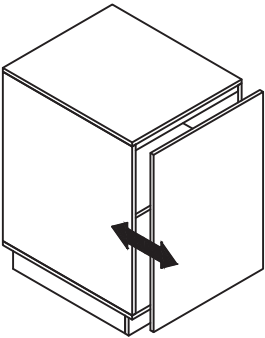

### To adjust depth.

Loosen screw "B" and adjust door, if the door can not be adjusted, please loosen screw "C", then try again. Tighten screw "B" and "C".

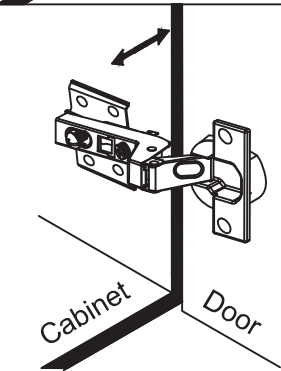
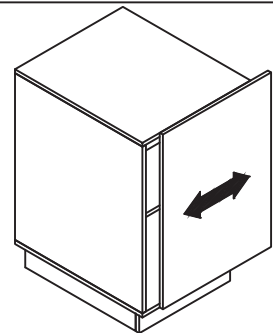

### To adjust side ways.

Turning the screw "C" on BOTH hinges on each door.

\* raw edges are shaded

This step is for fireplace insert installation .

## STEP 18

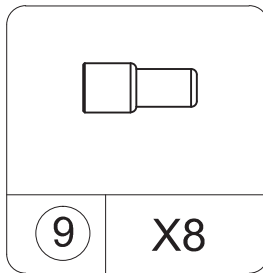
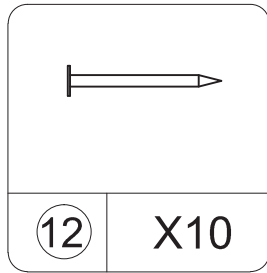
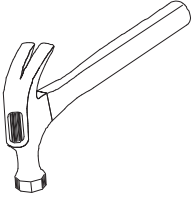

**IMPORTANT! THE BACK PANEL IS A STRUCTURAL PART OF THIS UNIT AND MUST BE INSTALLED PROPERLY.**

- Attach (J) to pre-assembled unit as below shown.
- Attach (I) to pre-assembled unit as below shown.

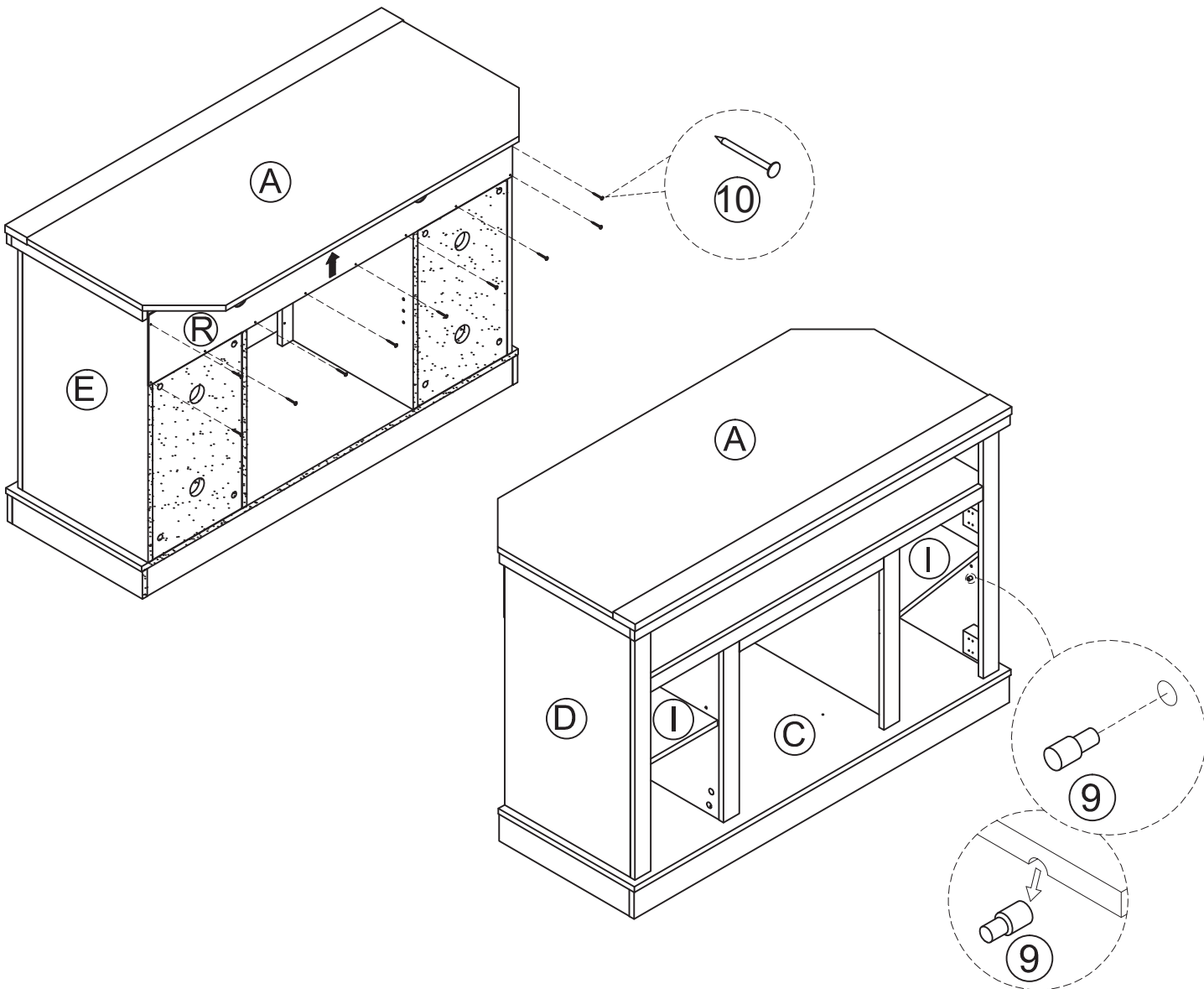

\* raw edges are shaded

This step is for fireplace insert installation .

## STEP 19

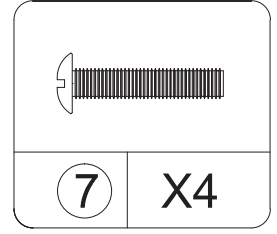
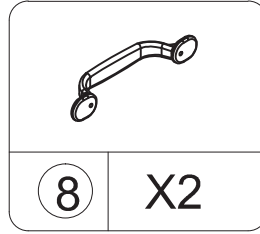
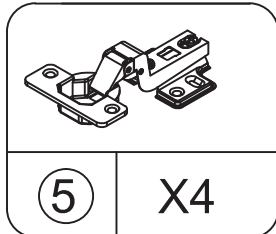
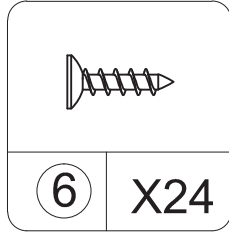
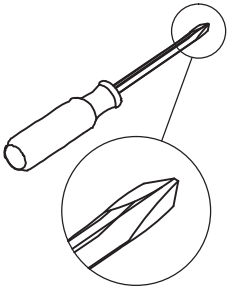

- Attach (O) to (D) & (E) as below shown.

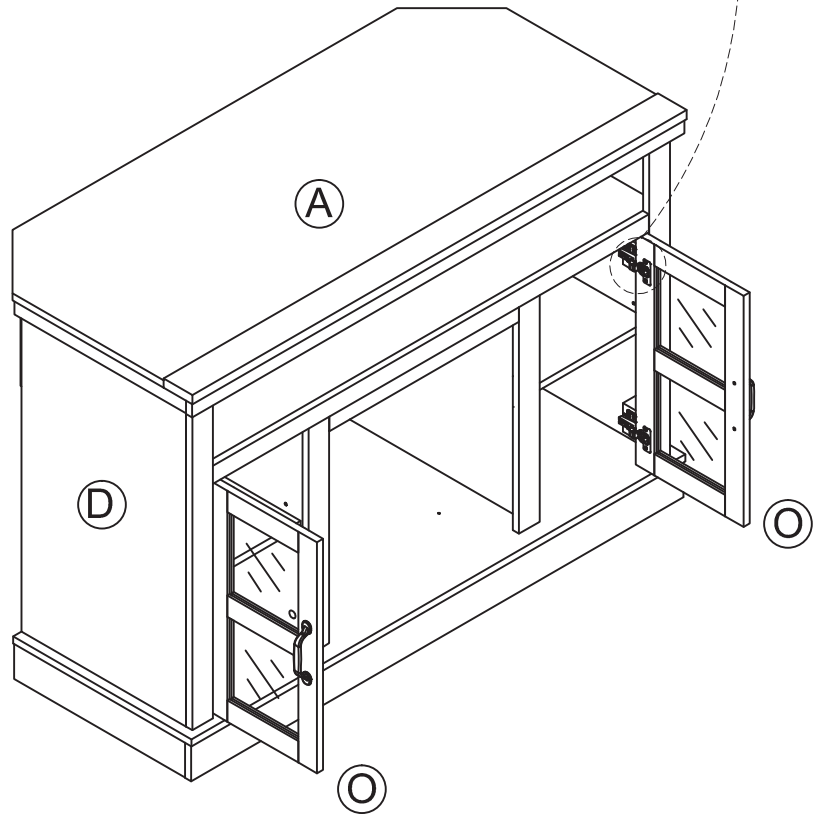
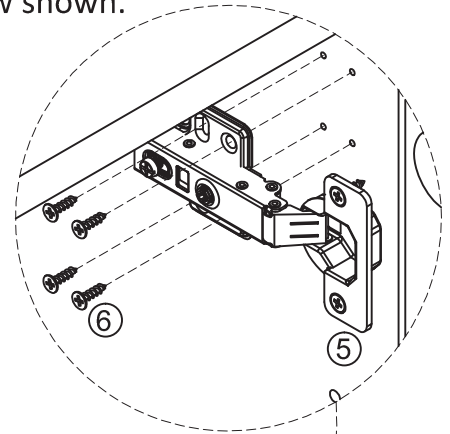
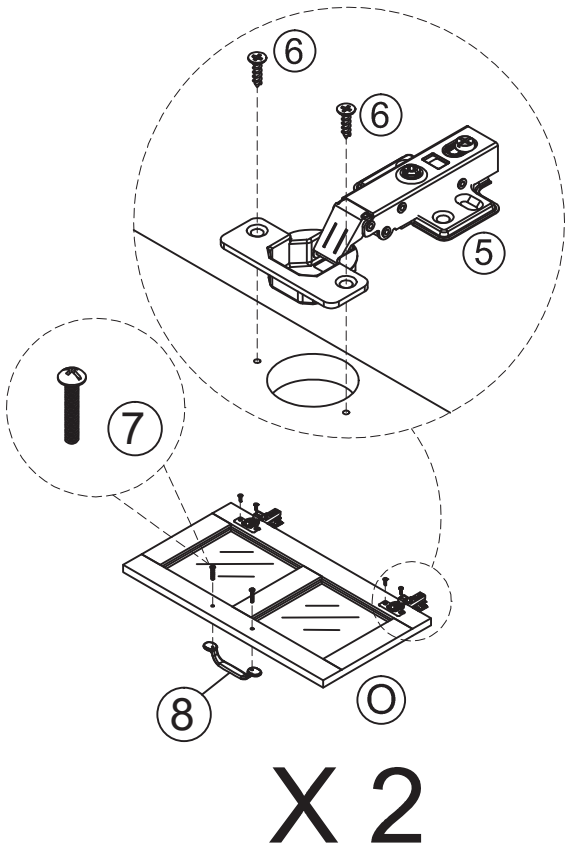

\* raw edges are shaded

This step is for fireplace insert installation .

## STEP 20

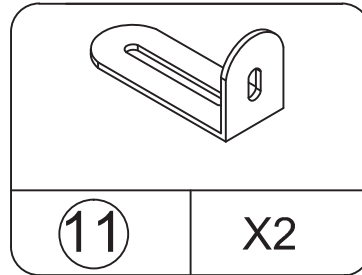
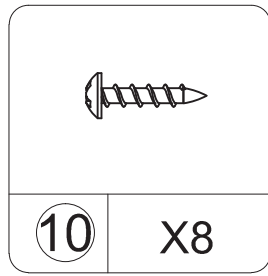
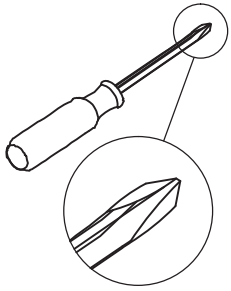

- Attach fireplace to pre-assembled unit as below shown.

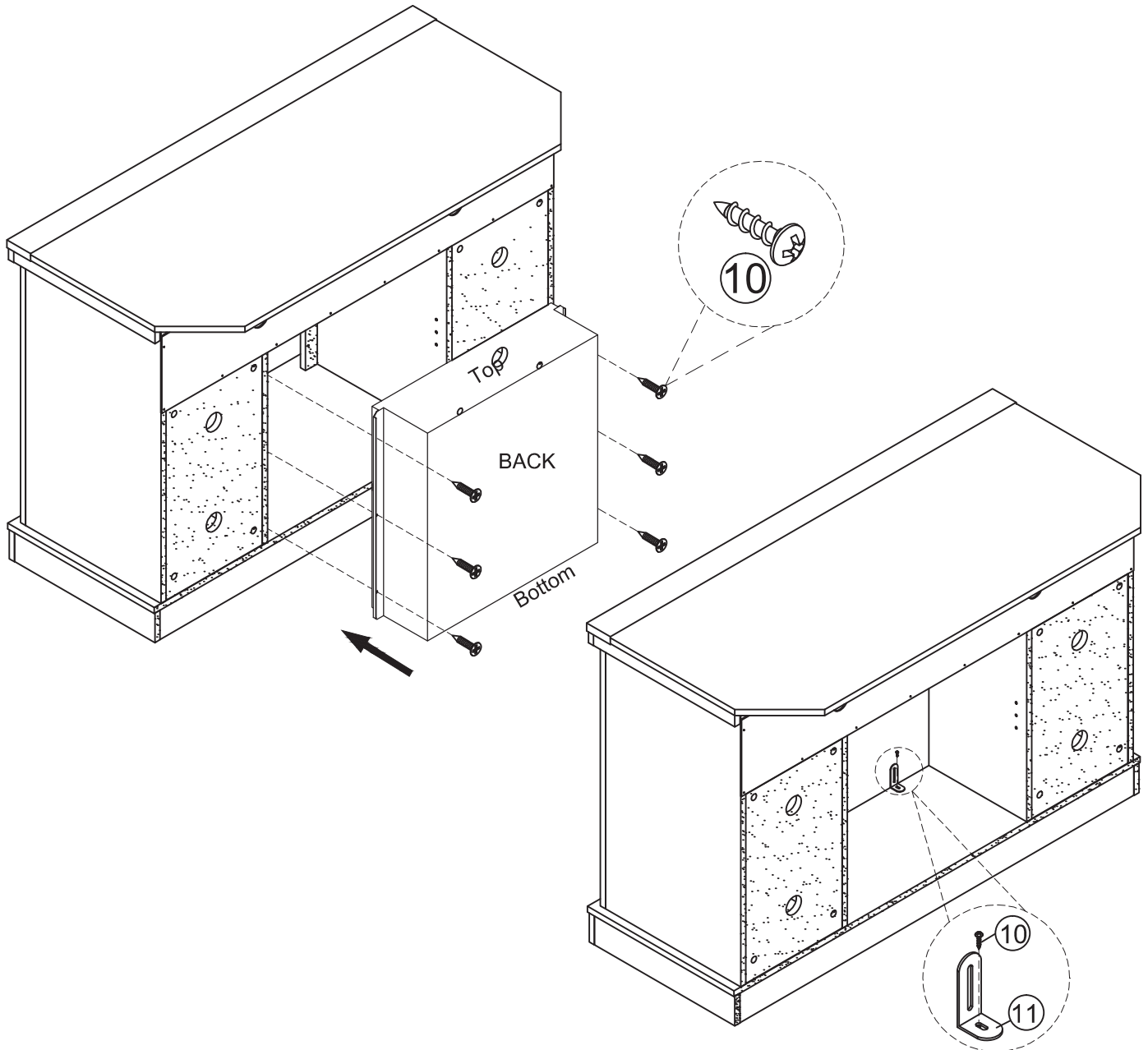

\* raw edges are shaded

This step is for fireplace insert installation .

## STEP 21

### BEFORE CONNECTING THE UNIT TO A WALL ELECTRIC OUTLET

Please carefully read and follow instructions and safety warnings in “Fireplace Homeowners Operating Manual” to operate your fireplace.

### WARNING

IF THE INFORMATION IN THE FIREPALCE OPERATING MANUAL IS NOT FOLLOWED, AN ELECTRIC SHOCK OR FIRE MAY RESULT IN PROPERTY DAMAGE, PERSONAL INJURY , OR LOSS OF LIFE .

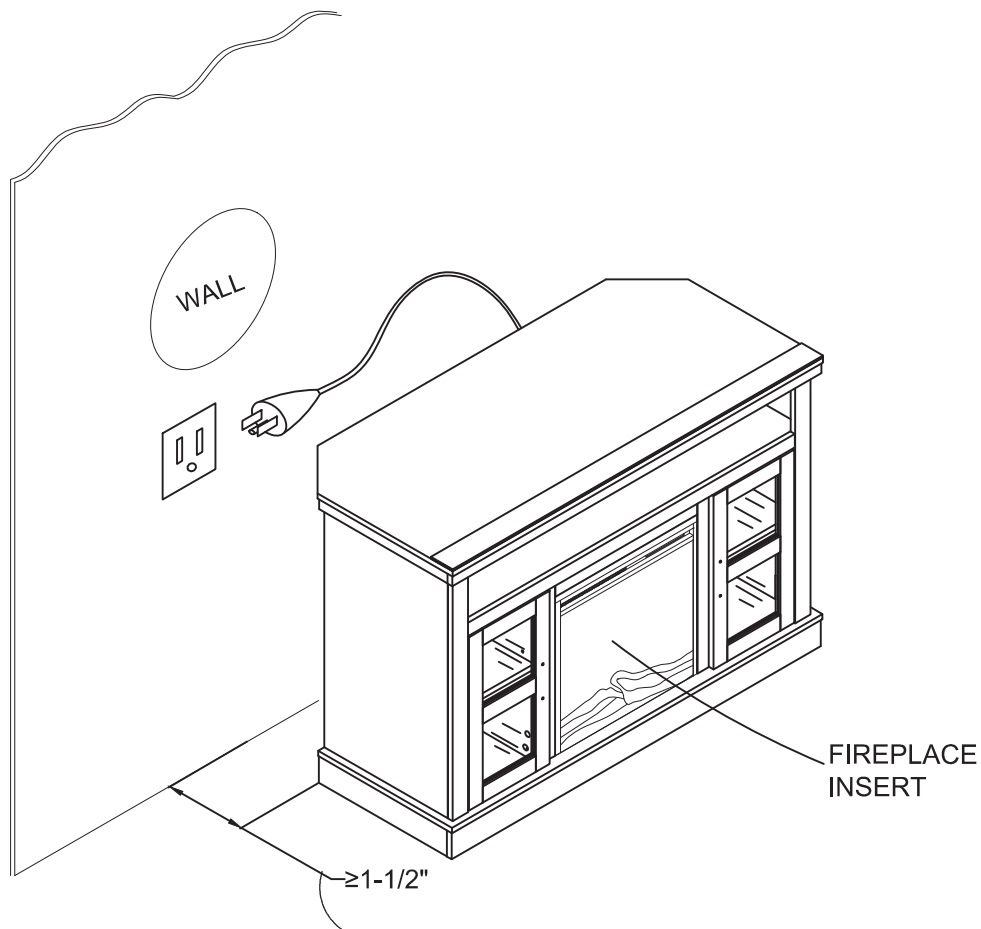

To allow proper heater ventilation, this unit must be located a minimum of 1-1/2” away from a back wall.

# Maximum Loads

This unit has been designed to support the maximum loads shown. Exceeding these load limits could cause sagging, instability, product collapse, and/or serious injury.

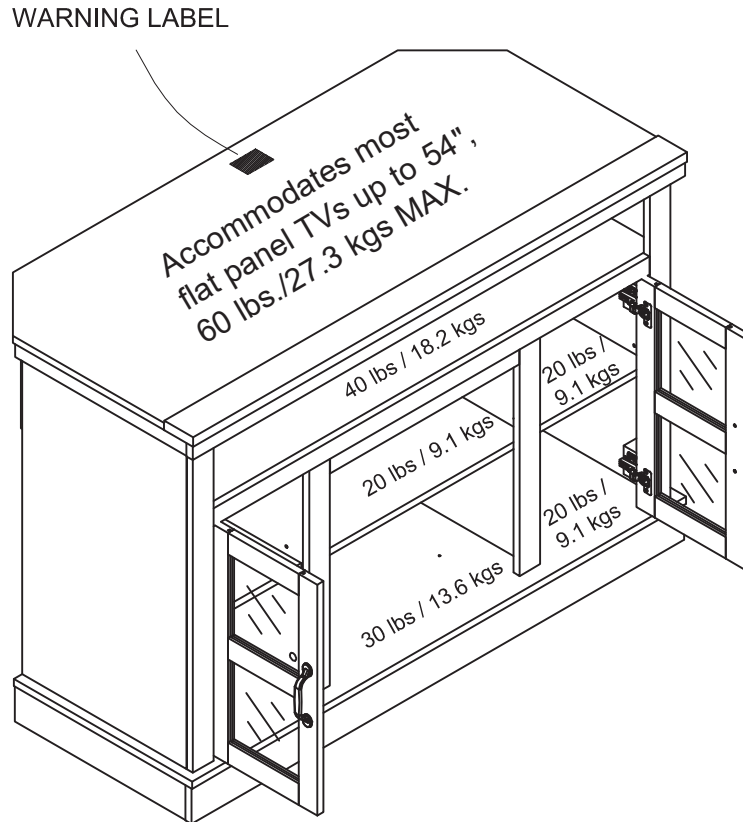

Apply the warning label to the center of the top panel as shown, ensure the TV covers the label in use. You will not be able to remove the label after it is applied to the top panel.

### Certificate of Conformity

1. This certificate applies to the Dorel Home Furnishings, Inc. product identified by this instruction manual.
2. This certificate applies to compliance of this product with the CPSC Ban on Lead-Containing Paint (16 CFR 1303).
3. This product is distributed by: Dorel Home Furnishings, Inc.  
410 East First Street South  
Wright City, MO 63390  
636-745-3351
4. Site of Manufacture: Zhejiang China
5. See front page of instruction manual for date of manufacture.

# Maximum Loads

This unit has been designed to support the maximum loads shown. Exceeding these load limits could cause sagging, instability, product collapse, and/or serious injury.

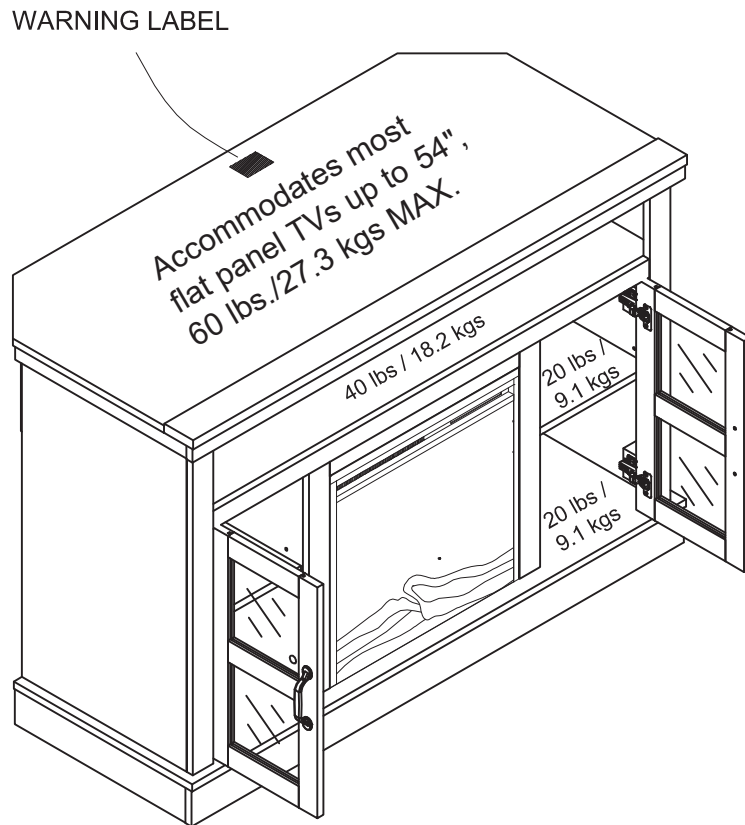

Apply the warning label to the center of the top panel as shown, ensure the TV covers the label in use. You will not be able to remove the label after it is applied to the top panel.

## Certificate of Conformity

1. This certificate applies to the Dorel Home Furnishings, Inc. product identified by this instruction manual.
2. This certificate applies to compliance of this product with the CPSC Ban on Lead-Containing Paint (16 CFR 1303).
3. This product is distributed by: Dorel Home Furnishings, Inc.  
410 East First Street South  
Wright City, MO 63390  
636-745-3351
4. Site of Manufacture: Zhejiang China
5. See front page of instruction manual for date of manufacture.

---

## Register your product to receive the following:



- \* New trend details - sneak peek on what's new
- \* Surveys - have a voice within our community
- \* Exclusive deals and discount codes
- \* Quick and easy replacement part service

To register your product, visit [ameriwoodhome.com](http://ameriwoodhome.com)

## *5 Star Rating*



Visit your local retailer's website, rate your purchased product and leave us some feedback!

We would like to extend a big "Thank You" to all of our customers for taking the time to assemble this Ameriwood Home product, and to give us your valuable feedback.

*Thank  
You!*



## Cubierta Delantera

Este libro de instrucciones contiene información **IMPORTANTE** de seguridad. Por favor lea y manténgalo para referencia en el futuro.

**No Regrese este producto!** Comuníquese con nuestro amigoso equipo de servicio al cliente para obtener ayuda.

Llámenos al: 1-800-489-3351 (Gratis) Lunes - Viernes 9am - 5pm CST

**Visitar:** [www.ameriwoodhome.com](http://www.ameriwoodhome.com)

## PRECAUCION

Este mueble puede volcarse y causar graves heridas y/o muerte.

Anclar el mueble a un poste de madera en la pared (si esto se requiere).

No Permita que los niños monten el mueble.

Mantenga los artículos más pesados en los cajones de abajo.

## Consejos Útiles (página 2)

- Abra su artículo en el área donde usted planea utilizarlo para evitar levantar y moverlo menos
- Identificar, ordenar y contar las piezas antes de intentar ensamblar
- Las clavijas de compresión se golpean con un martillo
- Las diapositivas están marcadas con una R (derecha) y L (izquierda) para la colocación correcta
- Asegúrese de que siempre este el punto localizado en la parte superior de bloqueador de leva este volteado hacia borde exterior
- Utilizar todos los clavos para el panel de atrás y distribuirlos por igual
- El panel de atrás debe utilizarse para asegurarse de que la unidad quede fija y firme
- No use químicas fuertes ni limpiadores abrasivos en este artículo
- Nunca empuje, tire ni arrastre los muebles

## Antes de Que Empieces (página 3)

- Lea cuidadosamente cada paso y siga el orden correcto

- Separar y contar todas sus piezas y hardware

- Dése suficiente espacio para el proceso de ensamble

- Tenga las siguientes herramientas: destornillador de cabeza plana, #2 cabeza Phillips

Destornillador y martillo

- Precaución: Si usa un taladro electrónico o un destornillador eléctrico para atornillar, por favor asegúrese que deje de atornillar cuando el tornillo este apretado. Fallar hacer esto puede causar barrer el tornillo.

## Sistema de fijar el bloqueo de leva (página 3)

Esta sistema de fijar el bloqueo de leva sera usado en todo el proceso ensamble.

## Página 9

Inserte (3) a (A) como se muestra abajo.

Atornille (2) a (A) & (G) como se muestra abajo.

Ate (G) a (A) como se muestra abajo.

## Identificación de los Paneles (Página 4, 5)

Este no es el tamaño real

- (A) Panel superior
- (B) Repisa fija
- (C) Base
- (D) Panel izquierdo
- (E) Panel lateral derecho
- (F) Partición
- (G) Riel frontal
- (H) Repiza central ajustable
- (I) Repiza lateral ajustable
- (J) Panel trasero medio
- (K) Panel trasero lateral
- (L) Riel medio
- (M) Riel izquierdo
- (N) Riel derecha
- (O) Puerta
- (P) Partición superior
- (Q) Rail superior
- (R) Panel trasero superior
- (S) Rail repisa fija
- (T) Riel frontal superior
- (U) Riel inferior izquierda
- (V) Riel inferior derecha
- (W) Riel trasero inferior
- (X) Riel frontal inferior

## Página 10

Ate (T) & (Q) a (A) como se muestra abajo.

Inserte (3) a (B) como se muestra abajo.

## Página 11

Inserte (3) a (L) como se muestra abajo.

Atornille (2) a (B) & (S) como se muestra abajo.

## Página 12

Ate (L) & (S) a (B) como se muestra abajo.

## Página 13

Inserte (3) a (D) & (E) & (P) & (K) como se muestra abajo.

Atornille (2) a (D) & (E) como se muestra abajo.

## Número de referencia de la bolsa de herrajes:

**24917335COM0EL**

## Lista de Piezas (Página 7, 8)

Tamaño real

- (2) Tornillo de rosca
- (3) Clavija de madera
- (4) Tornillo
- (6) Tornillo
- (7) Tornillo
- (10) Tornillo
- (12) Clavo

Este no es el tamaño real

- (1) Tornillo de cerradura
- (5) Bisagra
- (8) Manija
- (9) Soporte de repisa
- (11) Soporte para la pared
- (13) Etiqueta de advertencia

**Página 14**

Inserte (3) a (F) como se muestra abajo.  
Atornille (2) a (M) & (N) como se muestra abajo.  
Ate (M) & (N) a (F) como se muestra abajo.

**Página 15**

Atornille (2) a (F) como se muestra abajo.  
Ate (K) a (F) como se muestra abajo.

**Página 16**

Ate (F) a (B) como se muestra abajo.

**Página 17**

Ate (D) & (E) a la unidad montada como se muestra abajo.

**Página 18**

Atornille (2) a (C) como se muestra abajo.

**Página 19**

Inserte (3) a (U) & (V) & (W) & (X) como se muestra abajo.  
Atornille (2) a (U) & (V) & (W) & (X) como se muestra abajo.  
Ate (U) & (V) a (W) & (X) como se muestra abajo.

**Página 20**

Ate (U) & (V) & (W) & (X) a (C) como se muestra abajo.

**Página 21**

Ate (C) & (P) a la unidad montada como se muestra abajo.

**Página 22**

Ate (A) a la unidad montada como se muestra abajo.

**Página 23**

**IMPORTANT: El Panel trasero es una parte estructural de la unidad y debe ser instalado correctamente.**

Ate (R) a la unidad montada como se muestra abajo.

Asegura que e; inidad es cuadrada.

Distancia de esquina a esquina debe ser igual como se muestra por favor.

## Página 24&27

Ate (O) a (D) & (E) como se muestra abajo.

## Página 25

### Para ajustar la altura vertical.

Afloje los cuatro tornillos "A" en ambas bisagras. Dos de esos están usualmente en los agujeros llanos. Lo que significa que usted puede regular de arriba hacia abajo. Por unos pocos milímetros. Luego apriete hacia arriba.

### Para ajustar profundo.

Afloje los tornillos "B" y ajuste la puerta, si la puerta no puede ser ajustada. Por favor afloje los tornillos "C" y luego trate otra vez.

Apriete los tornillos "B" y "C".

### Para ajustar los lados marcados

Gire los tornillos "C" de ambas bisagras en cada puerta.

## Página 26

**IMPORTANT:** El Panel trasero es una parte estructural de la unidad y debe ser instalado correctamente.

Ate (J) a la unidad montada como se muestra abajo.

Ate (I) a la unidad montada como se muestra abajo.

Asegura que e; inidad es cuadrada.

Distancia de esquina a esquina debe ser igual como se muestra por favor.

## Página 28

Ate chimenea a la unidad montada como se muestra abajo.

## Página 29

### ANTES DE CONECTAR LA UNIDAD A UNA TOMA DE CORRIENTE ELÉCTRICA

Por favor lea detenidamente y siga las instrucciones y advertencias de seguridad en el "Manual Operativo para Propietarios de Chimenea" para funcionar su chimenea.

### ADVERTENCIA

SI NO SIGUE LA INFORMACIÓN EN EL MANUAL OPERATIVO PARA PROPIETARIOS DE CHIMENEA, UNA DESCARGA ELÉCTRICA O UN INCENDIO PUEDE RESULTAR EN DAÑO DEL PRODUCTO, LESIONES PERSONALES O MUERTE.

Para permitir una ventilación adecuada del calentador, esta unidad debe ubicarse a un mínimo de 1-1 / 2 "de distancia de una pared posterior.

## **Página 30&31**

### **CARGA MAXIMA**

Esta unidad ha sido diseñada para soportar la carga máxima anotada. El exceder estos límites puede causar inestabilidad, colapsarse y/o causar serias lesiones.

### **ETIQUETA DE ADVERTENCIA**

Se ajusta a la mayoría de las televisiones de pantalla plana de hasta 54", 60 lbs./27.3 kgs.

Pegue la etiqueta de advertencia en el centro del panel superior como se muestra, asegúrese de que la TV cubra la etiqueta antes de pegarla. Usted no podrá quitar la etiqueta una vez que se esta se aplique en el panel superior.

## **Página 32**

Registre su producto para recibir lo siguiente:

- \* Detalles de nuevas tendencias - Vistazo a lo nuevo
- \* Encuestas - alec su voz entre su comunidad
- \* Códigos de ofertas y descuentos exclusivos
- \* Fácil y rápido servicio de partes de remplace

Para registrar su producto, visite [ameriwoodhome.com](http://ameriwoodhome.com)

Clasificación de 5 estrellas

Visite el sitio web de su tienda local, califique su comprado y denos sus comentarios!

Nos gustaría enviar un gran "Agradecimiento" a todos nuestros clientes por tomarse el tiempo de ensamblar este producto de Ameriwood Home, y por darnos sus valiosos comentarios.

Gracias

## Couverture Avant

CE LIVRET D'INSTRUCTION CONTIENT DES INFORMATIONS **IMPORTANTES** SUR LA SÉCURITÉ. VEUILLEZ LIRE ET GARDER POUR UNE RÉFÉRENCE FUTURE

**Ne retournez pas ce produit!** Contactez notre équipe de service à la clientèle amicale d'abord pour obtenir de l'aide.

**Appelez-nous:** 1-866-452-4081 (sans frais) du Lundi au Vendredi de 9h à 17h Heure Centrale

**Visitez:** [www.systembuild.com](http://www.systembuild.com)

## ATTENTION

Le meuble peut basculer et causer des blessures graves ou la mort.

Ancrer le meuble à une planche murale dans le mur (si indiqué).

Ne laissez pas les enfants grimper sur le meuble.

Placez les articles lourds sur les étagères ou dans les tiroirs inférieurs.

## Astuces Utiles (page 2)

-Ouvrez votre article dans la zone que vous prévoyez de le garder pour moins de levage lourd

-Identifier, trier et compter les pièces avant d'essayer d'assembler

-Les goujons de compression sont taraudés avec un Marteau

-Les glissières sont marquées d'un R (droit) et d'un L (gauche) pour un bon placement

-Assurez-vous toujours de faire face la pointe situé sur le haut de la Serrure de Came vers le bord extérieur

-Utiliser tous les clous fournis pour le panneau arrière et les répartir également

-Le panneau arrière doit être utilisé pour vous assurer que votre appareil est robuste

-N'utilisez pas de produits chimiques agressifs ou de nettoyants abrasifs sur cet appareil

-Ne jamais pousser, tirer, ou faire glisser votre meuble

## Avant de Commencer (page 3)

-Lisez attentivement chaque étape et suivez le bon ordre

-Séparez et comptez toutes vos pièces et matériaux

-Donnez-vous suffisamment de place pour l'assemblage

-Avoir les outils suivants: tournevis à tête plate, #2 tournevis Phillips, et Marteau

-Attention: Si vous utilisez une perceuse électrique ou un tournevis électrique pour visser, veillez à ralentir et arrêter lorsque la vis est bien serrée. Le non-respect de cette consigne peut endommager la vis.

## Système de Fixation de Came (page 3)

Ce Système de Fixation de Came sera utilisé tout au long de l'assemblage

### Page 9

Insérez (3) dans (A) comme indiqué ci-dessous.

Vissez (2) dans (A) & (G) comme indiqué ci-dessous.

Fixez (G) à (A) comme indiqué ci-dessous.

### Page 10

Fixez (T) & (Q) à (A) comme indiqué ci-dessous.

Insérez (3) dans (B) comme indiqué ci-dessous.

## Identification des matériaux (Page 4, 5)

Pas de taille réelle

- (A) DESSUS
- (B) TABLETTE FIXE
- (C) DESSOUS
- (D) PANNEAU GAUCHE
- (E) PANNEAU DROIT
- (F) CLOISON
- (G) RAIL AVANT
- (H) TABLETTE CENTRALE RÉGLABLE
- (I) TABLETTE LATÉRALE AJUSTABLE
- (J) PANNEAU ARRIÈRE CENTRAL
- (K) PANNEAU ARRIÈRE CADRE
- (L) RAIL CENTRAL
- (M) RAIL GAUCHE
- (N) RAIL DROITE
- (O) PORTE
- (P) CLOISON SUPÉRIEUR
- (Q) RAIL SUPÉRIEUR
- (R) PANNEAU ARRIÈRE SUPÉRIEUR
- (S) RAIL TABLETTE FIXE
- (T) RAIL SUPÉRIEURE AVANT
- (U) RAIL INFÉRIEUR GAUCHE
- (V) RAIL INFÉRIEUR DROITE
- (W) RAIL ARRIÈRE INFÉRIEUR
- (X) RAIL AVANT INFÉRIEUR

### Page 11

Insérez (3) dans (L) comme indiqué ci-dessous.  
Vissez (2) dans (B) & (S) comme indiqué ci-dessous.

### Page 12

Fixez (L) & (S) a (B) comme indiqué ci-dessous.

### Page 13

Insérez (3) dans (D) & (E) & (P) & (K) comme indiqué ci-dessous.  
Vissez (2) dans (D) & (E) comme indiqué ci-dessous.

### Page 14

Insérez (3) dans (F) comme indiqué ci-dessous.  
Vissez (2) dans (M) & (N) comme indiqué ci-dessous.  
Fixez (M) & (N) a (F) comme indiqué ci-dessous.

## Numéro de référence du sac de quincaillerie:

**24917335COM0EL**

## Liste des pièces (Page 7, 8)

Taille réelle

- (2) BOULON DE CAME
- (3) GOUJON EN BOIS
- (4) VIS
- (6) VIS
- (7) BOULON
- (10) VIS
- (12) CLOU

Pas de taille réelle

- (1) SERRURE DE CAME
- (5) CHARNIÈRE
- (8) MANIPULER
- (9) SUPPORT DE TABLETTE
- (11) SUPPORT MURAL
- (13) AVERTISSEMENT ÉTIQUETTE

# Français

---

**Page 15**

Vissez (2) dans (F) comme indiqué ci-dessous.  
Fixez (K) a (F) comme indiqué ci-dessous.

**Page 16**

Fixez (F) a (B) comme indiqué ci-dessous.

**Page 17**

Fixez (D) & (E) a l'unité assemblé de l'étape précédente comme indiqué ci-dessous.

**Page 18**

Vissez (2) dans (C) comme indiqué ci-dessous.

**Page 19**

Insérez (3) dans (U) & (V) & (W) & (X) comme indiqué ci-dessous.  
Vissez (2) dans (U) & (V) & (W) & (X) comme indiqué ci-dessous.  
Fixez (U) & (V) a (W) & (X) comme indiqué ci-dessous.

**Page 20**

Fixez (U) & (V) & (W) & (X) a (C) comme indiqué ci-dessous.

**Page 21**

Fixez (C) & (P) a l'unité assemblé de l'étape précédente comme indiqué ci-dessous.

**Page 22**

Fixez (A) a l'unité assemblé de l'étape précédente comme indiqué ci-dessous.

**Page 23**

**IMPORTANT:** Le panneau arrière est une partie structurelle de cet appareil et doit être installé correctement.

Fixez (R) a l'unité assemblé de l'étape précédente comme indiqué ci-dessous.

Assurez-vous que le meuble est à égalité.  
La disancee de coin doit être égale comme montré.

**Page 24&27**

Fixez (O) a (D) & (E) comme indiqué ci-dessous.



## Page 25

### **Pour régler la hauteur verticale.**

Desserrez les quatre vis "A" sur les deux charnières. Deux d'entre elles sont habituellement dans des fentes afin de vous permettre de les ajuster vers le haut ou le bas de quelques mm. Resserrez les vis après l'ajustement.

### **Pour régler la profondeur.**

Desserrez la vis "B" et ajustez la porte. Si la porte ne peut pas s'ajuster, desserrez la vis "C", puis essayez de nouveau.

Serrez les vis "B" et "C".

### **Pour régler latéralement.**

Tournez la vis "C" sur les DEUX charnières de chaque porte.

## Page 26

**IMPORTANT:** Le panneau arrière est une partie structurelle de cet appareil et doit être installé correctement.

Fixez (J) à l'unité assemblée de l'étape précédente comme indiqué ci-dessous.

Fixez (I) à l'unité assemblée de l'étape précédente comme indiqué ci-dessous.

Assurez-vous que le meuble est à égalité.

La distance de coin doit être égale comme montré.

## Page 28

Fixez cheminée à l'unité assemblée de l'étape précédente comme indiqué ci-dessous.

## Page 29

### **AVANT DE BRANCHER L'APPAREIL À UNE PRISE ÉLECTRIQUE MURALE**

Veuillez lire et suivre attentivement les instructions et les mises en garde de sécurité dans le "Mode d'emploi du Manuel du propriétaire du Foyer" pour faire fonctionner votre foyer.

#### MISE EN GARDE

SI LES INFORMATIONS DANS LE MANUEL DU PROPRIÉTAIRE DU FOYER NE SONT PAS SUIVIES ATTENTIVEMENT, UN CHOC ÉLECTRIQUE OU UN INCENDIE PEUT SE PRODUIRE ET CAUSER DES DOMMAGES MATÉRIELS, DES BLESSURES, OU DES PERTES DE VIES.

Pour permettre une bonne ventilation du radiateur, cet appareil doit être situé à 1-1/2" d'un mur arrière.

## Page 30&31

### CHARGES MAXIMALES

Ce meuble a été conçu pour supporter les charges maximales indiquées. En excédant ces limites de charge, le meuble pourrait devenir instable, s'effondrer, et/ou causer des blessures graves.

### AVERTISSEMENT ÉTIQUETTE

Peut accueillir la plupart des TV à écran plat jusqu'à 54", 27.3 kg (60 lb) MAX.

Appliquez l'étiquette de mise en garde au centre du panneau supérieur comme montré. Assurez-vous que le téléviseur couvre l'étiquette utilisée. Vous ne pourrez pas retirer l'étiquette après l'avoir appliquée sur le panneau supérieur.

## Page 32

Enregistrez votre produit pour recevoir les éléments suivantes:

- \* Détails sur les nouvelles tendances - un aperçu sur les nouveautés
- \* Sondages - avoir une voix au sein de notre communauté
- \* Offres exclusives et codes promo
- \* Service de pièces de rechange rapide et facile

Pour enregistrer votre produit, visitez [systembuild.com](http://systembuild.com)

### 5 Étoiles

Visitez le site Web de votre détaillant local, évaluez votre produit acheté et laissez-nous quelques commentaires !

Nous tenons à offrir un grand "Merci" à tous nos clients pour avoir pris le temps d'assembler ce produit "Systembuild", et de nous donner vos commentaires précieux.

Merci